

MANUFACTURERS MOTOR VEHICLE SPECIFICATIONS

METRIC (U.S. Customary)

1993

B
④

| | | |
|---|---|----------------|
| Manufacturer CHEVROLET MOTOR DIVISION GENERAL MOTORS CORPORATION | Vehicle Line  BERETTA | |
| Mailing Address CHEVROLET-PONTIAC-CANADA GROUP ENGINEERING CENTER GENERAL MOTORS CORPORATION 30003 VAN DYKE WARREN, MICHIGAN 48090-9060 | Issued NOVEMBER, 1992 | Revised |

Direct questions concerning these specifications to the manufacturer listed above.

The information contained herein is prepared, distributed by, and is solely the responsibility of the vehicle manufacturing company to whose products it relates. This specification form was developed by the vehicle manufacturing companies under the auspices of the Motor Vehicle Manufacturers Association of the United States, Inc.

The General Specifications herein are those in effect at date of compilation and are subject to change without notice or incurring obligation by the manufacturer.



Motor Vehicle Manufacturers Association
of the United States, Inc.

Blank Forms Provided by Technical Affairs Division

MVMA Specifications

METRIC (U.S. Customary)

Table of Contents

| | | | | |
|----------|-------|---|----------|---|
| | 1 | Vehicle Models/Origin | O | Indicates Format Change From Previous Year |
| O | 2 | Power Teams | | |
| | 3 | Engine | | |
| | 4 | Lubrication System | | |
| | 4 | Diesel Information | | |
| O | 5 | Cooling System | | |
| | 6 | Fuel System | | |
| | 7 | Vehicle Emission Control | | |
| | 7 | Exhaust System | | |
| O | 8-10 | Transmission, Axles and Shafts | | |
| | 11 | Suspension | | |
| O | 12-13 | Brakes, Tires and Wheels | | |
| | 14 | Steering | | |
| | 15-16 | Electrical | | |
| | 17 | Body — Miscellaneous Information | | |
| | 17 | Frame | | |
| | 18 | Restraint System | | |
| O | 18 | Glass | | |
| | 18 | Headlamps | | |
| | 19 | Climate Control System | | |
| O | 20-21 | Convenience Equipment | | |
| | 21 | Trailer Towing | | |
| | 22-24 | Vehicle Dimensions | | |
| | 25 | Vehicle Fiducial Marks | | |
| | 26 | Vehicle Mass (Weight) | | |
| | 27 | Optional Equipment Differential Mass (Weight) | | |
| | 28-34 | Vehicle Dimensions Definitions - Key Sheets | | |
| | 35 | Index | | |

NOTE:

1. This form uses both SI metric units and U.S. Customary units. The metric unit of measure is presented first, and the U.S. Customary unit follows in parentheses.
2. UNLESS OTHERWISE INDICATED:
 - a. Specifications apply to standard models without optional equipment. Significant deviations are noted.
 - b. Nominal design dimensions are used throughout these specifications.
 - c. All linear dimensions are in millimeters (inches), and all mass (weight) specifications are in kilograms (pounds).
3. The General Specifications herein are those in effect at date of compilation and are subject to change without notice or incurring obligation by the manufacturer.
4. Additional Vehicle Dimensions (based in part on SAE J1100 "Motor Vehicle Dimensions") may be available from the manufacturer.

MVMA Specifications

Vehicle Line BERETTA
 Model Year 1993 Issued 9-92 Revised(*) _____

METRIC (U.S. Customary)

Vehicle Origin

| | |
|--|--------------------------------|
| Design & development (company) | Chevrolet-Pontiac-GM of Canada |
| Where built (country) | U.S.A. |
| Authorized U.S. Sales marketing representative | Chevrolet Motor Division |

Vehicle Models

| Model Description & Drive (FWD/RWD/AWD/4WD)* | Make, Vehicle Models, Series, Body Type (Mfr's Model Code) | No. of Designated Seating Positions (Front/Rear) | Max. Trunk/Cargo Load-Kilograms (Pounds) | EPA Fuel Economy (City/Hwy) |
|---|--|--|--|-----------------------------|
| BERETTA 2-Door Notchback Coupe (FWD) | 1LV37 | 5 (2/3) | 64 (141) | 25/34 |
| BERETTA 'GT' 2-Door Notchback Coupe (FWD) | 1LW37 | 5 (2/3) | 64 (141) | 25/34 |
| BERETTA 'GTZ' 2-Door Notchback Coupe (FWD) | 1LZ37 | 5 (2/3) | 64 (141) | 21/30 |

* FWD - Front Wheel Drive RWD - Rear Wheel Drive AWD - All Wheel Drive 4WD - Four Wheel Drive

MVMA Specifications

Vehicle Line BERETTA
 Model Year 1993 Issued 9-92 Revised(*)

METRIC (U.S. Customary)

Engine Description 2.2 LITER L4 (133 CID)
 Engine Code MULTI-PORT FUEL INJECTION RPO LN2

ENGINE - GENERAL

| | | |
|--|---|---|
| Type & description (inline, V, angle, flat, location, front, mid, rear, transverse, longitudinal, sohc, dohc, ohv, hemi, wedge, pre-chamber, etc.) | Inline, Front, Transverse - OHV | |
| Manufacturer | General Motors Powertrain Division | |
| No. of cylinders | 4 | |
| Bore | 89.0 mm (3.50 in.) | |
| Stroke | 88.0 mm (3.46 in.) | |
| Bore spacing (C/L to C/L) | 99.0 mm (3.90 in.) | |
| Cyl block matl & mass kg(lbs.)(machined) | Cast Iron, 40 (88) | |
| Cylinder block deck height | 216.65 mm (8.53 in.) | |
| Cylinder block length | 443 mm (17.44 in.) | |
| Deck clearance (minimum) (above or below block) | .6 mm (.024 in.) Below | |
| Cyl. head material & mass kg (lbs.) | Aluminum, 9.7 (21.3) | |
| Cylinder head volume cu. cm. (cu. in.) | 32.8 (2.00) | |
| Cylinder liner material | No Liner | |
| Head gasket thickness (compressed) | 1.50 (.059) | |
| Minimum combustion chamber total volume cu. cm. (cu. in.) | 67.34 (4.11) | |
| Cyl. no. system (front to rear)* | L. Bank | 1-2-3-4 |
| | R. Bank | - |
| Firing order | 1-3-4-2 | |
| Intake manifold matl & mass kg (lbs.)** | Aluminum, 3.9 (8.6) | |
| Exh. manifold matl & mass kg (lbs.)** | Nodular Cast Iron, 4.5 (10) | |
| Knock sensor (number & location) | None | |
| Fuel required unleaded, diesel, etc. | Unleaded | |
| Fuel antiknock index (R + M) / 2 | 87 | |
| Engine mounts | Quantity | 3 Manual 2 Auto |
| | Matl and type (elastomeric, hydroelastic, hydraulic damper, etc.) | Hydroelastic Elastomeric |
| | Added isolation (sub-frame, crossmember, etc.) | No |
| Total dressed engine mass (wt) dry*** | 163.3 kg. (359 lbs.), Manual 147.7 kg. (325 lbs.), Automatic | |

Engine - Pistons

| | |
|--|-----------------------|
| Material & mass, g (weight, oz.) - piston only | Aluminum, 328 (11.57) |
|--|-----------------------|

Engine Camshaft

| | | |
|-----------------------------------|----------------------|-------------------------------|
| Location | In Block, Right Side | |
| Material & mass kg (weight, lbs.) | Cast Iron, 3.1 (6.8) | |
| Drive type | Chain/belt | Chain |
| | Width/pitch | 19.3 / 9.5 mm (.76 / .37 in.) |

*Rear of engine - drive takeoff. View from drive takeoff end to determine left & right side of engine.
 **Finished state.
 ***Dressed engine mass (weight) includes the following:

All those items necessary to make the engine a complete ready-to-run unit.

MVMA Specifications

Vehicle Line BERETTA
 Model Year 1993 Issued 9-92 Revised _____

METRIC (U.S. Customary)

Engine Description
 Engine Code

2.3 LITER L4 (138 CID)
 MULTI-PORT FUEL INJECTION RPO LGO

ENGINE - GENERAL

| | | |
|--|---|-------------------------------|
| Type & description (inline, V, angle, flat, location, front, mid, rear, transverse, longitudinal, sohc, dohc, ohv, hemi, wedge, pre-chamber, etc.) | Inline, Front, Transverse, Pent Roof | |
| Manufacturer | General Motors Powertrain Division | |
| No. of cylinders | 4 | |
| Bore | 92 mm (3.63 in.) | |
| Stroke | 85 mm (3.35 in.) | |
| Bore spacing (C/L to C/L) | 100 mm (3.94 in.) | |
| Cyl blk matl & mass kg(lbs.)(machined) | Cast Iron, 48.05 (105.93) | |
| Cylinder block deck height | 222 mm (8.74 in.) | |
| Cylinder block length | 499.5 (19.66) | |
| Deck clearance (minimum) (above or below block) | 0 | |
| Cyl. head material & mass kg (lbs.) | Aluminum Alloy, 8.60 (18.96) | |
| Cylinder head volume cu. cm. (cu. in.) | 47.0 +/- 1.5 cc | |
| Cylinder liner material | None | |
| Head gasket thickness (compressed) | 1.10 (.043) | |
| Minimum combustion chamber total volume cu. cm. (cu. in.) | 62.8 | |
| Cyl. no. system (front to rear)* | L. Bank | 1-2-3-4 |
| | R. Bank | None |
| Firing order | 1-3-4-2 | |
| Intake manifold matl & mass kg (lbs.)** | Aluminum, 5.3 (11.72) | |
| Exh. manifold matl & mass kg (lbs.)** | Cast Iron, 6.74 (14.86) | |
| Knock sensor (number & location) | 0 | |
| Fuel required unleaded, diesel, etc. | Unleaded | |
| Fuel antiknock index (R + M) / 2 | 87 | |
| Engine mounts | Quantity | 2 |
| | Matl and type (elastomeric, hydroelastic, hydraulic damper, etc.) | Elastomeric Hydroelastic |
| | Added isolation (sub-frame, crossmember, etc.) | No |
| Total dressed engine mass (wt) dry*** | 158.30 (348.99) | |

Engine - Pistons

| | |
|--|----------------------|
| Material & mass, g (weight, oz.) - piston only | Aluminum 419 (14.78) |
|--|----------------------|

Engine Camshaft

| | | |
|-----------------------------------|-------------|---|
| Location | Overhead | |
| Material & mass kg (weight, lbs.) | Intake | 3.045 (6.713) |
| | Exhaust | 2.948 (6.499) |
| Drive type | Chain/belt | Chain |
| | Width/pitch | 22.86 mm 9.525mm (.375 in.) Duplex ~ 130 pitches |

*Rear of engine - drive takeoff. View from drive takeoff end to determine left & right side of engine.
 **Finished state.
 ***Dressed engine mass (weight) includes the following:

MVMA Specifications

Vehicle Line BERETTA
 Model Year 1993 Issued 9-92 Revised(*)

METRIC (U.S. Customary)

Engine Description
 Engine Code

2.2 LITER L4 (133 CID)
 MULTI-PORT FUEL INJECTION RPO LN2

Engine - Valve System

| | | |
|--------------------------------------|--------------------------|---|
| Hydraulic lifters (std., opt., n.a.) | | Standard |
| Valves | Number intake/exhaust | 4/4 |
| | Head O.D. intake/exhaust | 44.0 mm (1.73 in.) / 37.0 mm (1.46 in.) |

Engine - Connecting Rods

| | |
|--|---------------------------|
| Material & mass kg., (weight, lbs.)* | Forged Steel, .540 (1.19) |
| Length (axes centerline to centerline) | 141.95 (5.59) |

Engine - Crankshaft

| | | |
|--|--------------------------------|---------------------------|
| Material & mass kg., (weight, lbs.)* | Nodular Cast Iron, 14.4 (31.7) | |
| End thrust taken by bearing (no.) | 4 | |
| Length & number of main bearings | 5, 20.72 mm (.82 in.) | |
| Seal (material, one, two piece design, etc.) | Front | One Piece Fluoroelastomer |
| | Rear | One Piece Fluoroelastomer |

Engine - Lubrication System

| | |
|--|------------------------|
| Normal oil pressure kPa (psi) @ eng rpm | 435-530 (63-77) @ 1200 |
| Type oil intake (floating, stationary) | Stationary |
| Oil filter sys. (full flow, part, other) | Full Flow |
| Capacity of c/case, less filter-refill-L (qt.) | 3.8 (4.0) |

Engine - Diesel Information

(NOT APPLICABLE)

| | | |
|---|----------------------------|--|
| Diesel engine manufacturer | | |
| Glow plug, current drain at 0 deg. F | | |
| Injector Nozzle | Type | |
| | Opening pressure kPa (psi) | |
| Pre-chamber design | | |
| Fuel injection pump | Manufacturer | |
| | Type | |
| Fuel inj. pump drive (belt, chain, gear) | | |
| Supplementary vacuum source (type) | | |
| Fuel heater (yes/no) | | |
| Water separator, description (std., opt.) | | |
| Turbo manufacturer | | |
| Oil cooler-type (oil to engine coolant; oil to ambient air) | | |
| Oil filter | | |

Engine - Intake System

(NOT APPLICABLE)

| | | |
|------------------------------|--|--|
| Turbo charger - manufacturer | | |
| Super charger - manufacturer | | |
| Intercooler | | |

* Finished State

MVMA Specifications

Vehicle Line BERETTA
 Model Year 1993 Issued 9-82 Revised(*) _____

METRIC (U.S. Customary)

| | |
|--------------------|-----------------------------------|
| Engine Description | 3.1 LITER V6 (191 CID) |
| Engine Code | MULTI-PORT FUEL INJECTION RPO LHO |

Engine - Valve System

| | | |
|--------------------------------------|--------------------------|---|
| Hydraulic lifters (std., opt., n.a.) | Standard | |
| Valves | Number intake/exhaust | 8/6 |
| | Head O.D. intake/exhaust | 43.64mm (1.72 in.) / 36.20mm (1.43 in.) |

Engine - Connecting Rods

| | |
|--|---|
| Material & mass kg., (weight, lbs.)* | Forged Steel, .592 (1.31) Full Assembly |
| Length (axes centerline to centerline) | 144.78 (5.79) |

Engine - Crankshaft

| | | |
|--|--------------------------------|------------------------|
| Material & mass kg., (weight, lbs.)* | Nodular Cast Iron, 17.2 (37.9) | |
| End thrust taken by bearing (no.) | 3 | |
| Length & number of main bearings | ** 4 Bearings | |
| Seal (material, one, two piece design, etc.) | Front | Viton/Steel, One Piece |
| | Rear | Viton/Steel, One Piece |

Engine - Lubrication System

| | |
|---|------------------------|
| Normal oil pressure kPa (psi) @ eng rpm | 345-450 (50-65) @ 2400 |
| Type oil intake (floating, stationary) | Stationary |
| Oil filter sys. (full flow, part, other) | Full Flow |
| Capacity of c/case, less filter-refill-L (qt) | 3.8 (4.0) |

Engine - Diesel Information

(NOT APPLICABLE)

| | | |
|---|----------------------------|--|
| Diesel engine manufacturer | | |
| Glow plug, current drain at 0 deg. F | | |
| Injector Nozzle | Type | |
| | Opening pressure kPa (psi) | |
| Pre-chamber design | | |
| Fuel injection pump | Manufacturer | |
| | Type | |
| Fuel inj. pump drive (belt, chain, gear) | | |
| Supplementary vacuum source (type) | | |
| Fuel heater (yes/no) | | |
| Water separator, description (std., opt.) | | |
| Turbo manufacturer | | |
| Oil cooler-type (oil to engine coolant; oil to ambient air) | | |
| Oil filter | | |

Engine - Intake System

(NOT APPLICABLE)

| | |
|------------------------------|--|
| Turbo charger - manufacturer | |
| Super charger - manufacturer | |
| Intercooler | |

* Finished State

** Bearing Overall Length:

For 3.1L V6: #1, 4 = 29.5 mm (1.16 in.); #2, 3 = 24.0 mm (0.96 in.)

MVMA Specifications

Vehicle Line BERETTA
 Model Year 1993 Issued 9-92 Revised(*)

METRIC (U.S. Customary)

Engine Description
 Engine Code

2.3 LITER L4 (138 CID)
 MULTI-PORT FUEL INJECTION RPO LGO

Engine - Valve System

| | | |
|--------------------------------------|--------------------------|---|
| Hydraulic lifters (std., opt., n.a.) | | Standard |
| Valves | Number intake/exhaust | 8/8 |
| | Head O.D. intake/exhaust | 36.50 mm (1.44 in.) / 31.50 mm (1.24 in.) |

Engine - Connecting Rods

| | |
|---------------------------------------|------------------------|
| Material & mass kg., (weight, lbs.) * | Steel, .689 (1.5) Each |
| Length(axes centerline to centerline) | 147.5 (5.81) |

Engine - Crankshaft

| | | |
|--|---|------------------|
| Material & mass kg., (weight, lbs.) * | Nodular Iron, 19.0 (41.9) | |
| End thrust taken by bearing (no.) | #3 | |
| Length & number of main bearings | #1, 2, 4, & 5 21.25 mm (.84 in.) #3 27.25 mm (1.09 in.)/5 | |
| Seal (material, one, two piece design, etc.) | Front | One Piece, Viton |
| | Rear | One Piece, Viton |

Engine - Lubrication System

| | |
|--|--------------------|
| Normal oil pressure kPa(psi) @ eng rpm | 207 (30) @ 2000 |
| Type oil intake (floating, stationary) | Stationary Pick-Up |
| Oil filter sys. (full flow, part, other) | Full Flow |
| Capacity of c/case, less filter-refill-L (qt.) | 3.79 (4) |

Engine - Diesel Information

(NOT APPLICABLE)

| | |
|---|---------------------------|
| Diesel engine manufacturer | |
| Glow plug, current drain at 0 deg. F | |
| Injector Nozzle | Type |
| | Opening pressure kPa(psi) |
| Pre-chamber design | |
| Fuel injection pump | Manufacturer |
| | Type |
| Fuel inj. pump drive (belt, chain, gear) | |
| Supplementary vacuum source (type) | |
| Fuel heater (yes/no) | |
| Water separator, description (std., opt.) | |
| Turbo manufacturer | |
| Oil cooler-type (oil to engine coolant; oil to ambient air) | |
| Oil filter | |

Engine - Intake System

(NOT APPLICABLE)

| | |
|------------------------------|--|
| Turbo charger - manufacturer | |
| Super charger - manufacturer | |
| Intercooler | |

* Finished State

MVMA Specifications

Vehicle Line BERETTA
 Model Year 1993 Issued 9-92 Revised _____

METRIC (U.S. Customary)

Engine Description
 Engine Code

2.2 LITER L4 (133 CID)
 MULTI-PORT FUEL INJECTION RPO LN2

Engine - Cooling System

| | | |
|---|---|---|
| Coolant recovery system (std., opt. n.a.) | | Standard |
| Coolant fill location (rad., bottle) | | Surge Tank |
| Radiator cap relief valve pressure kPa (psi) | | 124 (18) |
| Circulation thermostat | Type (choke, bypass) | Choke |
| | Starts to open @ deg's C(F) | 89 (192) |
| Water Pump | Type (centrifugal, other) | Centrifugal |
| | GPM 1000 pump rpm | 7.3 |
| | Number of pumps | 1 |
| | Drive (V-belt, other) | V-Belt |
| | Bearing type | Sealed, Ball Roller |
| | Impeller material | Stamped Steel |
| | Housing material | Aluminum |
| By-pass recirculation type (inter., ext.) | | External - Thru Intake Manifold Internal |
| Cooling system capacity | With heater - L (qt.) | 8.7 (9.2) |
| | With air conditioner-L(qt.) | 8.7 (9.2) |
| | Opt. equip. specify-L(qt.) | |
| Water jackets full length of cy(Yes,no) | | Yes |
| Water all around cylinder (yes, no) | | Yes |
| Water jackets open at head face (yes,no) | | Yes |
| Radiator core | Std., A/C, HD | Standard A/C |
| | Type (cross-flow, etc.) | Cross-Flow |
| | Construction (fin & tube mechanical, braze, etc.) | Tube & Center / Brazed |
| | Matl., mass kg (wgt., lbs.) | Aluminum 3.08 (6.78), Standard; 3.95 (8.69), Auto. |
| | Width | 660 (26) |
| | Height | 383 (15) |
| | Thickness | 24 (.9) |
| Fins per inch | | 13, Standard 17, Auto. |
| Radiator end tank material | | Plastic |
| Fan | Std., elec., opt. | Electric, Standard Air Conditioned |
| | Number of blades & type (flex, solid, material) | 5 Plastic 7 Plastic |
| | Number & location (front, rear of radiator) | |
| | Diameter & projected width | 290 (11.4) 373 (14.7) |
| | Ratio(fan to crnkshft.rev.) | Not Applicable |
| | Fan cutout type | ECM Controlled |
| | Drive type (direct, remote) | Direct - Electric Motor |
| | RPM at idle (elec.) | 1800 |
| | Motor rating(wattage/elec.) | 100 |
| | Motor switch (type & location/elec.) | ECM |
| Switch point (temp./ pressure/elec.) | | On At 108; Off at 101 On At 106; Off At 99 |
| Fan shroud (material) | | None Plastic |

MVMA Specifications

Vehicle Line BERETTA
 Model Year 1993 Issued 9-92 Revised _____

METRIC (U.S. Customary)

Engine Description
 Engine Code

3.1 LITER V6 (191 CID)
 MULTI-PORT FUEL INJECTION RPO LH0

Engine - Cooling System

| | | |
|---|--|--|
| Coolant recovery system (std, opt, n.a.) | | Standard |
| Coolant fill location (rad., bottle) | | Surge Tank |
| Radiator cap relief valve pressure kPa (psi) | | 124 (18), Surge Tank Cap |
| Circulation thermostat | Type (choke, bypass) | Bypass |
| | Starts to open @ deg's C(F) | 90 (195) |
| Water Pump | Type (centrifugal, other) | Centrifugal |
| | GPM 1000 pump rpm | 12 |
| | Number of pumps | 1 |
| | Drive (V-belt, other) | Serpentine |
| | Bearing type | Ball-Roller |
| | Impeller material | Cast Iron |
| Housing material | | Aluminum |
| By-pass recirculation type (inter., ext.) | | External, Bypass |
| Cooling system capacity | With heater - L (qt.) | 12.33 (13.1) |
| | With air conditioner-L(qt.) | 12.47 (13.2) |
| | Opt. equip. specify-L(qt.) | None |
| Water jackets full length of cyl(yes,no) | | Yes, Outer Wall; No, Inner Wall |
| Water all around cylinder (yes, no) | | Yes |
| Water jackets open at head face (yes,no) | | Yes |
| Radiator core | Std., A/C, HD | All |
| | Type (cross-flow, etc.) | Cross Flow |
| | Construction (fin & tube mechanical, braze, etc.) | Tube & Fine/Brazed |
| | Matl. mass kg (wt.,lbs.) | Aluminum 4.20 (9.24), Standard; 4.88 (10.74), Auto. |
| | Width | 660 (26) |
| | Height | 383 (15.1) |
| | Thickness | 24 (0.9), Standard 34 (1.3) |
| Fins per inch | | 17 |
| Radiator end tank material | | Plastic |
| Fan | Std., elec., opt. | Electric - Standard Air Conditioned |
| | Number of blades & type (flex, solid, material) | 5 Plastic 6 Plastic |
| | Number & location (front, rear of radiator) | |
| | Diameter & projected width | 290 (11.4) 373 (14.7) |
| | Ratio(fan to crnkshft.rev.) | Not Applicable |
| | Fan cutout type | ECM Controlled |
| | Drive type (direct, remote) | Electric |
| | RPM at idle (elec.) | 1800 |
| | Motor rating(wattage/elec.) | 100 150 |
| | Motor switch (type & location/elec.) | ECM |
| Switch point (temp.,/ pressure/elec.) | On At 190, Off At 100 PSI A/C Pressure On At 106, Off At 100 Deg. C | |
| Fan shroud (material) | | None Plastic |

MVMA Specifications

Vehicle Line BERETTA
 Model Year 1993 Issued 9-92 Revised _____

METRIC (U.S. Customary)

| | |
|--------------------|-----------------------------------|
| Engine Description | 2.3 LITER L4 (138 CID) |
| Engine Code | MULTI-PORT FUEL INJECTION RPO LG0 |

Engine - Cooling System

| | | |
|--|--|------------------------------|
| Coolant recovery system (std, opt, n.a.) | Standard | |
| Coolant fill location (rad., bottle) | Surge Tank | |
| Radiator cap relief valve pressure kPa (psi) | 124 (18), Surge Tank Cap | |
| Circulation thermostat | Type (choke, bypass) | Bypass |
| | Starts to open @ deg's C(F) | 89 (192) |
| Water Pump | Type (centrifugal, other) | Centrifugal |
| | GPM 1000 pump rpm | 6.5 |
| | Number of pumps | 1 |
| | Drive (V-belt, other) | Chain |
| | Bearing type | 2 Row Ball |
| | Impeller material | Sheet Metal |
| | Housing material | Die Cast Aluminum |
| By-pass recirculation type (inter., ext.) | External - Heater Water Flow & Throttle Body Water Flow | |
| Cooling system capacity | With heater - L (qt.) | 9.8 (10.4) |
| | With air conditioner-L(qt.) | 9.8 (10.4) |
| | Opt. equip. specify-L(qt.) | None |
| Water jackets full length of cy(yes,no) | Yes | |
| Water all around cylinder (yes, no) | Partial | |
| Water jackets open at head face (yes,no) | Partial | |
| Radiator core | Std., A/C, HD | Standard & A/C |
| | Type (cross-flow, etc.) | Cross-Flow |
| | Construction (fin & tube mechanical, braze, etc.) | Tube & Center / Brazed |
| | Matl. mass kg (wgt., lbs.) | Aluminum 3.08 (6.78) |
| | Width | 660 (26) |
| | Height | 383 (15.1) |
| | Thickness | 24 (0.9) |
| Fins per inch | 13 | |
| Radiator end tank material | Plastic | |
| Fan | Std., elec., opt. | Electric |
| | Number of blades & type (flex, solid, material) | 6 - Nylon 6/6 Mineral Filled |
| | Number & location (front, rear of radiator) | |
| | Diameter & projected width | 381 (15.0) |
| | Ratio(fan to crnkshft.rev.) | Not Applicable |
| | Fan cutout type | Engine Control Module (ECM) |
| | Drive type (direct, remote) | Electric - Direct |
| | RPM at idle (elec.) | 1800 |
| | Motor rating(wattage/elec.) | 150 |
| | Motor switch (type & location/elec.) | ECM |
| Switch point (temp.,/ pressure/elec.) | One At 106 deg. (223) Coolant Temperature Or 190 PSI A/C Head Pressure | |
| Fan shroud (material) | None | |

MVMA Specifications

Vehicle Line BERETTA
 Model Year 1993 Issued 9-92 Revised(*) _____

METRIC (U.S. Customary)

| | |
|--------------------|-----------------------------------|
| Engine Description | 2.2 LITER L4 (133 CID) |
| Engine Code | MULTI-PORT FUEL INJECTION RPO LN2 |

Engine - Fuel System (See supplemental page for details of Fuel Inj, Supercharger, Turbocharger, etc. if used)

| | | |
|---|---|--|
| Induction type: carburetor, fuel injection system, etc. | | Fuel Injection |
| Manufacturer | | AC/Rochester Products |
| Carburetor no. of barrels | | None |
| Idle A/F mix. | | Preset - No Adjustment Provided |
| Fuel Injection | Point of inj. (no.) | Entering Cylinder Head (Four) |
| | Constant, pulse, flow | Pulse |
| | Control (elec., mech.) | Electronic |
| | Sys. press. kPa (psi) | 294 - 306 (43 - 44) |
| Idle spd.-rpm (spec. neutral or drive and propane if used) | Manual | 900 In Neutral |
| | Automatic | 700 In Drive. |
| Intake manifold heat control (exhaust or water thermostatic or fixed) | | None |
| Air cleaner type | | Single Snorkel |
| Fuel filter (type/location) | | Replaceable Paper Element Located Near Fuel Tank |
| Fuel pump | Type (elec. or mech.) | Electrical |
| | Location (eng., tank) | Fuel tank |
| | Press. range kPa (psi) | Pressure Depends On Flow Rate And System Voltage |
| | Flow rate at regulated pressure (L (gal)/hr @ kPa (psii)) | 62.4 @ 350 (16.51 @ 50.8) Figures For Wide Open Throttle |

Fuel Tank

| | | |
|----------------------------------|-----------------------|---|
| Capacity refill L (gallons) | | 59.0 (15.6) |
| Location (describe) | | Under Rear Seat (Forward Of Rear Axle) |
| Attachment | | Two Longitudinal Steel Straps |
| Material & Mass kg (weight lbs.) | | High Density Polyethylene 8.92 (20.46) W/Sender |
| Filler pipe | Location & material | Right Rear Quarter - Steel |
| | Connection to tank | Fuel Filler And Vent Hose With Clamps |
| Fuel line (material) | | Steel/Nylon With Quick Connect Fittings |
| Fuel hose (material) | | Filler Hose - Rubber |
| Return line (material) | | Steel/Nylon With Quick Connect Fittings |
| Vapor line (material) | | Steel/Rubber |
| Extended range tank | Opt., n.a. | Not Applicable |
| | Capacity L (gallons) | " |
| | Location & material | " |
| | Attachment | " |
| Auxiliary tank | Opt., n.a. | " |
| | Capacity L (gallons) | " |
| | Location & material | " |
| | Attachment | " |
| | Sictr switch or valve | " |
| Separate fill | | " |

MVMA Specifications

Vehicle Line BERETTA
 Model Year 1993 Issued 9-92 Revised(*) _____

METRIC (U.S. Customary)

Engine Description
 Engine Code

3.1 LITER V6 (191 CID)
 MULTI-PORT FUEL INJECTION RPO LHO

Engine - Fuel System (See supplemental page for details of Fuel Inj, Supercharger, Turbocharger, etc. if used)

| | | |
|---|--|--|
| Induction type: carburetor, fuel injection system, etc. | | Fuel Injection |
| Manufacturer | | AC/Rochester Products |
| Carburetor no. of barrels | | None |
| Idle A/F mix. | | Preset-No Adjustment Provided |
| Fuel Injection | Point of inj. (no.) | Fuel Injectors At Inlet Ports |
| | Constant, pulse, flow | Pulse |
| | Control (elec., mech.) | Electronic |
| | Sys. press. kPa (psi) | 300 (43.5), Regulated To Manifold Pressure |
| Idle spd.-rpm (spec. neutral or drive and propane if used) | Manual | Not Applicable |
| | Automatic | 600 In Drive |
| Intake manifold heat control (exhaust or water thermostatic or fixed) | | Throttle Body Water Heat - No Induction Air Heat |
| Air cleaner type | | Single Snorkel, Replaceable Paper Element |
| Fuel filter (type/location) | | Replaceable Enclosed Paper Element Located Near Fuel Tank. |
| Fuel pump | Type (elec. or mech.) | Electrical |
| | Location (eng., tank) | Fuel Tank |
| | Press. range kPa (psi) | Normal Operating Range 250 To 300 kPa (36 to 44 psi) |
| | Flow rate at regulated pressure (L (gal)/hr @ kPa (psi)) | 62.4 @ 350 (Pump Rating) (16.51 @ 50.8) |

Fuel Tank

| | | |
|----------------------------------|----------------------|---|
| Capacity refill L (gallons) | | 59.0 (15.6) |
| Location (describe) | | Under Rear Seat (Forward Of Rear Axle) |
| Attachment | | Two Longitudinal Steel Straps |
| Material & Mass kg (weight lbs.) | | High density Polyethylene 8.92 (20.46) W/Sender |
| Filler pipe | Location & material | Right Rear Quarter - Steel |
| | Connection to tank | Fuel Filler And Vent Hose With Clamps |
| Fuel line (material) | | Steel/Nylon With Quick Connect Fittings |
| Fuel hose (material) | | Filler Hose - Rubber |
| Return line (material) | | Steel/Nylon With Quick Connect Fittings |
| Vapor line (material) | | Steel/Rubber |
| Extended range tank | Opt., n.a. | Not Applicable |
| | Capacity L (gallons) | " |
| | Location & material | " |
| | Attachment | " |
| Auxiliary tank | Opt., n.a. | " |
| | Capacity L (gallons) | " |
| | Location & material | " |
| | Attachment | " |
| | Sicr switch or valve | " |
| Separate fill | | " |

MVMA Specifications

Vehicle Line BERETTA
 Model Year 1993 Issued 9-92 Revised(*) _____

METRIC (U.S. Customary)

Engine Description
 Engine Code

2.3 LITER L4 (138 CID)
 MULTI-PORT FUEL INJECTION RPO LGO

Engine - Fuel System (See supplemental page for details of Fuel Inj, Supercharger, Turbocharger, etc. if used)

| | | |
|---|--|--|
| Induction type: carburetor, fuel injection system, etc. | | Port Fuel Injection |
| Manufacturer | | AC/Rochester Products |
| Carburetor no. of barrels | | None |
| Idle A/F mix. | | ECM Controlled |
| Fuel injection | Point of inj. (no.) | 4 Injectors At Ports In Cylinder Head |
| | Constant, pulse, flow | Pulse |
| | Control (elec., mech.) | Electronic |
| | Sys. press. kPa (psi) | 300 (43) |
| Idle spd.-rpm (Spec. neutral or drive and propane if used) | Manual | |
| | Automatic | |
| Intake manifold heat control (exhaust or water thermostatic or fixed) | | None |
| Air cleaner type | | Single Snorkel, Remote Mounted, Replaceable Paper Element |
| Fuel filter (type/location) | | Replaceable Enclosed Paper Element Located Near Fuel Tank |
| Fuel pump | Type (elec. or mech.) | Electrical |
| | Location (eng., tank) | Fuel Tank |
| | Press. range kPa (psi) | Pressure Depends On Flow Rate And System Voltage |
| | Flow rate at regulated pressure (L (gal)/hr @ kPa (psi)) | 62.4 @ 350 (Figures For Wide Open Throttle) (16.51 @ 50.8) |

Fuel Tank

| | | |
|----------------------------------|-----------------------|---|
| Capacity refill L (gallons) | | 59.0 (15.6) |
| Location (describe) | | Under Rear Seat (Forward Of Rear Axle) |
| Attachment | | Two Longitudinal steel Straps |
| Material & Mass kg (weight lbs.) | | High Density Polyethylene 8.92 (20.46) W/Sender |
| Filler pipe | Location & material | Right rear Quarter - Steel |
| | Connection to tank | Fuel Filler And Vent Hose With Clamps |
| Fuel line (material) | | Steel/Nylon With Quick Connect Fittings |
| Fuel hose (material) | | Filler Hose - rubber |
| Return line (material) | | Steel/Nylon With Quick Connect Fittings |
| Vapor line (material) | | Steel/Rubber |
| Extended range tank | Opt., n.a. | Not Applicable |
| | Capacity L (gallons) | " |
| | Location & material | " |
| | Attachment | " |
| Auxiliary tank | Opt., n.a. | " |
| | Capacity L (gallons) | " |
| | Location & material | " |
| | Attachment | " |
| | Sictr switch or valve | " |
| Separate fill | | " |

MVMA Specifications

Vehicle Line BERETTA
 Model Year 1993 Issued 9-92 Revised(*)

METRIC (U.S. Customary)

Engine Description
 Engine Code

2.2 LITER L4 (133 CID)
 MULTI-PORT FUEL INJECTION RPO LN2

Vehicle Emission Control

| | | | |
|------------------------------|--|---|---|
| Exhaust Emission Control | Type (air injection, engine modifications, other) | | CCC Control |
| | Air injection | Pump or pulse | Not |
| | | Driven by | Applicable |
| | | Air distribution (head, manifold, etc.) | |
| | | Point of entry | |
| | Exhaust Gas Recirculation | Type (controlled flow, open orifice, other) | Negative Back Pressure EGR Valve With Integral Transducer And Single Shaft Cross Hole |
| | | Exhaust source | #4 Cylinder At Cylinder Head |
| | | Point of exh.inj. (spacer, carb. manifold, other) | Inlet Manifold |
| | Catalytic Converter | Type | 3-Way Monolith |
| | | Number of | 1 |
| Location(s) | | Mounted To Center Underbody | |
| Volume L (cu.in) | | 1.8 (110) | |
| Substrate type | | Monolith | |
| Noble metal type | | Palladium (Pd), Rhodium (Rh) | |
| Crankcase Emission Control | Type (ventilates to atmosphere, induction system, other) | | Induction System |
| | Energy source (manifold vacuum, carburetor, other) | | Manifold Vacuum |
| | Discharges to (intake manifold, other) | | Intake Manifold |
| | Air inlet (breather cap, other) | | Air Cleaner Outlet Duct |
| Evaporative Emission Control | Vapor vented to (crankcase, canister, other) | Fuel tank | Canister |
| | | Carburetor | - |
| | Vapor storage provision | | Canister |
| Electronic System | Closed loop (yes/no) | | Yes |
| | Open loop (yes/no) | | No |

Engine - Exhaust System

| | | |
|--|-----------------------------|--|
| Type (single, single with cross-over, dual, other) | | Single |
| Muffler no. & type (reverse flow, straight thru, separate resonator) Material & Mass kg (wght.lbs.) | | 1, Triflow. Muffler, Stainless Steel, 6.5 (14.4) |
| Resonator no. & type | | Not Applicable |
| Exhaust pipe | Branch o.d., wall thickness | " |
| | Main o.d., wall thickness | 50.8 x 1.77 mm (2.0 x .070 in.) |
| | Matl. & Mass kg (wght.lbs.) | 409 Stainless Steel, 3.4 (7.6) |
| Inter-mediate pipe | o.d. & wall thickness | 50.8 x 1.09 mm (2.0 x .043 in.) |
| | Matl. & Mass kg (wght.lbs.) | 409 Stainless Steel, 3.0 (6.7) |
| Tail pipe | o.d. & wall thickness | 50.8 x 1.09 mm (2.0 x .043 in.) |
| | Matl. & Mass kg (wght.lbs.) | 409 Stainless Steel, .4 (.9) |

MVMA Specifications

Vehicle Line BERETTA
 Model Year 1993 Issued 9-92 Revised(*)

METRIC (U.S. Customary)

Engine Description
 Engine Code

3.1 LITER V6 (191 CID)
 MULTI-PORT FUEL INJECTION RPO LHO

Vehicle Emission Control

Manual Transmission

Automatic Transmission

| Type (air injection, engine modifications, other) | | Not Applicable | Not Applicable |
|---|--|---|---|
| Air injection | Pump or pulse | " | " |
| | Driven by | " | " |
| | Air distribution (head, manifold, etc.,) | " | " |
| | Point of entry | " | " |
| Exhaust Gas Recirculation | Type (controlled flow, open orifice, other) | 3 Sized Orifices Which Are Opened Or Closed Using, Pintles And Solenoids. 8 Flow Combination. | |
| | Exhaust source Point of exh.inj. (spacer, carb., manifold, other) | Plenum, Near Throttle Body | |
| Catalytic Converter | Type | Bed Monolith (Dual) | |
| | Number of | 1 | |
| | Location(s) | Mounted To Underbody | |
| | Volume L (cu.in) | 2.79 (170) | |
| | Substrate type | Ceramic Monolith | |
| | Noble metal type | Platinum (Pt), Rhodium (Rh) | |
| Crankcase Emission Control | Type (ventilates to atmosphere, induction system, other) | Closed Induction System | |
| | Energy source (manifold vacuum, carburetor, other) | Plenum Vacuum | |
| | Discharges to (intake manifold, other) | Discharges To Plenum | |
| | Air inlet (breather cap, other) | Duct Between Air Cleaner And Throttle Body | |
| Evaporative Emission Control | Vapor vented to (crankcase, canister, other) | Fuel tank | Fuel Tank To Canister To Throttle Body Port |
| | | Carburetor | Not Applicable |
| | Vapor storage provision | Canister | |
| Electronic System | Closed loop (yes/no) | Yes | |
| | Open loop (yes/no) | No | |

Engine - Exhaust System

| | | |
|--|---|--|
| Type (single, single with cross-over, dual, other) | Single | |
| Muffler no. & type (reverse flow, straight thru, separate resonator) Material & Mass kg (weight lbs.) | 1, Triflow Muffler, Stainless Steel, 6.5 (14.4) | |
| Resonator no. & type | Not Applicable | |
| Exhaust pipe | Branch o.d., wall thickness | " |
| | Main o.d., wall thickness | 50.8 x 1.77 mm (2.0 x .070 in.) |
| | Matl. & Mass kg (wght.lbs.) | 409 Stainless Steel, 1.9 (4.2) |
| Inter-mediate pipe | o.d. & wall thickness | 50.8 x 1.09 mm (2.0 x .043 in.) |
| | Matl. & Mass kg (wght.lbs.) | 409 Stainless Steel, 3.0 (6.7) |
| Tail pipe | o.d. & wall thickness | 50.8 x 1.09 mm (2.0 x .043 in.)* |
| | Matl. & Mass kg (wght.lbs.) | 409 Stainless Steel, .8 (1.8); W/221 1.0 (2.2) |

* W/221 57.1 x 1.09 mm (2.2 x .043 in.)

MVMA Specifications

Vehicle Line BERETTA
 Model Year 1993 Issued 9-92 Revised(*) _____

METRIC (U.S. Customary)

Engine Description

2.3 LITER L4 (138 CID)

Engine Code

MULTI-PORT FUEL INJECTION RPO LG0

Vehicle Emission Control

| | | | |
|------------------------------|--|--|---|
| Exhaust Emission Control | Type (air injection, engine modifications, other) | | C3 Engine Modification |
| | Air injection | Pump or pulse | None |
| | | Driven by | |
| | | Air distribution (head, manifold, etc.) | |
| | | Point of entry | |
| | Exhaust Gas Recirculation | Type (controlled flow, open orifice, other) | California Only - Controlled Flow Dual None/Orifice Digital EGR Valve |
| | | Exhaust source | |
| | | Point of exh.inj. (spacer, carb., manifold, other) | Intake Manifold |
| | Catalytic Converter | Type | Single Bed |
| | | Number of | 1 |
| Location(s) | | Under Floor | |
| Volume L (cu.in) | | 2.671 (163) | |
| Substrate type | | Monolith - Ceramic | |
| Noble metal type | | Platinum (Pt), Paladium (Pd), Rhodium (Rh) | |
| Crankcase Emission Control | Type (ventilates to atmosphere, induction system, other) | | Orifice + Bypass. No PCV Valve. Closed - Ventilates To Induction System. |
| | Energy source (manifold vacuum, carburetor, other) | | Orificed Connection To Manifold Vacuum. Open Hose Connection To Clean Side Of A/C. |
| | Discharges to (intake manifold, other) | | Induction System |
| | Air inlt(breather cap, other) | | None |
| Evaporative Emission Control | Vapor vented to (crankcase, canister, other) | Fuel tank | Canister |
| | | Carburetor | None |
| | Vapor storage provision | | Charcoal Canister |
| Electronic System | Closed loop (yes/no) | | Yes |
| | Open loop (yes/no) | | No |

Engine - Exhaust System

| | | |
|---|-----------------------------|---|
| Type (single, single with cross-over, dual, other) | | Single |
| Muffler no. & type (reverse flow, straight thru, separate resonator) Material & Mass kg (weight lbs.) | | 1, Triflow Muffler, Stainless Steel, 7.5 (16.7) |
| Resonator no. & type | | 1, 63 mm O.D. "Bottle" Resonator |
| Exhaust pipe | Branch o.d., wall thickness | 44.5 x 1.9 mm (1.75 x .075 in.) |
| | Main o.d., wall thickness | 44.5 x 1.0 mm (1.75 x .040 in.) |
| | Matl. & Mass kg (wght.lbs.) | 409 Stainless Steel, 1.73 (3.81) |
| Inter-mediate pipe | o.d. & wall thickness | 50.8 x 1.89 mm (2.0 x .074 in.) |
| | Matl. & Mass kg (wght.lbs.) | 409 Stainless Steel, 5.0 (11.1) |
| Tail pipe | o.d. & wall thickness | 76.0 x .86 mm (3.0 x .034 in.) |
| | Matl. & Mass kg (wght.lbs.) | 304 Stainless Steel, 1.8 (4.0) |

MVMA Specifications

Vehicle Line BERETTA
 Model Year 1993 Issued 9-92 Revised _____

METRIC (U.S. Customary)

Engine Description
 Engine Code

2.2 LITER L4 (133 CID)
 MULTI-PORT FUEL INJECTION RPO LN2

Transmissions/Transaxle (Std., Opt., N.A.)

| | |
|--|--|
| Manual 4-speed (manufacturer/country) | Not Applicable |
| Manual 5-speed (manufacturer/country) | Standard Isuzu / Japan (MR3) |
| Manual 6-speed (manufacturer/country) | Not Applicable |
| Automatic (manufacturer/country) | Optional, General Motors Powertrain / U.S.A. |
| Auto. overdrive (manufacturer/country) | Not Applicable |

Manual Transmission/Transaxle

| | | |
|-------------------------------------|-----------------------|--------------------------------------|
| Number of forward speeds | 5 | |
| Gear ratios | 1st | 3.73 |
| | 2nd | 2.15 |
| | 3rd | 1.33 |
| | 4th | .923 |
| | 5th | 0.74 |
| | 6th | |
| | Reverse | 3.56 |
| Synchronous meshing (specify gears) | 1-5 | |
| Shift lever location | Floor | |
| Trans. case mat'l. & mass kg (lbs)* | Aluminum, 36.5 (80.1) | |
| Lubricant | Capacity L (pt.) | 1.9 (4.0) |
| | Type recommended | Synchromesh Transmission Fluid (STF) |

Clutch (Manual Transmission)

| | | |
|---|---|--|
| Clutch manufacturer | Daikin | |
| Clutch type (dry, wet; single, multiple disc) | Dry Disc, Single | |
| Linkage (hyd., cable, rod, lever, other) | Hydraulic | |
| Max. pedal effort (nom. spring load) N (lbs.) | Depressed | 133.4 (30.0) |
| | Released | 115.6 (26.0) |
| Assist (spring, power/percent, nominal) | None | |
| Type pressure plate springs | Diaphragm | |
| Total spring load (nominal) N (lbs) | 5688 (1279) | |
| Clutch facing | Facing mfr. & mat'l. coding | Valeo F202 |
| | Facing mat'l. & construction | f202 |
| | Rivets per facing | 16 |
| | Outside x inside dia. (nom.) | 215.0 x 150.0 (8.46 x 5.91) |
| | Total eff. area sq cm (sq in) | 186.3 (28.88) |
| | Thickness (pressure plate side/fly wheel side) | 3.5 (.14) Pressure Plate Side, 3.2 (.13) Flywheel Side |
| | Rivet depth (pressure plate side/fly wheel side) | 1.3 (0.05) / 1.2 (0.05) |
| Engagement cushion method | Driven Plate, Wave Spoke Springs | |
| Release bearing type & method lub. | Self Centering, Angular Contact Ball Bearing - Prepacked & Sealed | |
| Torsional damping method, springs, hysteresis | Coil Springs With Non-Metal Friction Control | |

* Includes shift linkage, lubricant, and clutch housing. If other specify.

MVMA Specifications

Vehicle Line BERETTA
 Model Year 1993 Issued 9-92 Revised _____

METRIC (U.S. Customary)

Engine Description 3.1 LITER V6 (191 CID)
 Engine Code MULTI-PORT FUEL INJECTION RPO LHO

Transmissions/Transaxle (Std., Opt., N.A.)

| | |
|--|--------------------------------------|
| Manual 4-speed (manufacturer/country) | |
| Manual 5-speed (manufacturer/country) | Standard - N. Venture/U.S.A. (MG2) |
| Manual 6-speed (manufacturer/country) | |
| Automatic (manufacturer/country) | Optional - Hydra-matic, U.S.A. (MD9) |
| Auto. overdrive (manufacturer/country) | |

Manual Transmission/Transaxle

| | | |
|-------------------------------------|------------------|--------------------------------------|
| Number of forward speeds | | 5 |
| Gear ratios | 1st | 3.50 |
| | 2nd | 2.05 |
| | 3rd | 1.38 |
| | 4th | 0.94 |
| | 5th | 0.72 |
| | 6th | |
| | Reverse | 3.41 |
| Synchronous meshing (specify gears) | | 1, 2, 3, 4 and 5 |
| Shift lever location | | Floor Mount |
| Trans. case mat'l. & mass kg (lbs)* | | Aluminum, 41.0 (90.2) |
| Lubricant | Capacity L (pt.) | 1.9 (4.01) |
| | Type recommended | Synchromesh Transmission Fluid (STF) |

Clutch (Manual Transmission)

| | | |
|---|--|--|
| Clutch manufacturer | | LUK |
| Clutch type (dry, wet; single, multiple disc) | | Dry Single Disc |
| Linkage (hyd., cable, rod, lever, other) | | Hydraulic |
| Max. pedal effort (nom. spring load) N (lbs.) | Depressed | 133.4 (30.0) |
| | Released | 133.4 (30.0) |
| Assist (spring, power/percent, nominal) | | Not Applicable |
| Type pressure plate springs | | Diaphragm |
| Total spring load (nominal) N (lbs) | | 6540 (1470) |
| Clutch facing | Facing mfr. & matl. coding | LUK |
| | Facing matl. & construction | Non-Asbestos |
| | Rivets per facing | 32 |
| | Outside x inside dia. (nom.) | 232 x 156 mm (9.12 x 6.12 in.) |
| | Total eff. area sq cm (sq in) | 232 (35.90) |
| | Thickness (pressure plate side/fly wheel side) | 7.50 - 8.00 mm (.295 - .315 in.) |
| | Rivet depth (pressure plate side/fly wheel side) | 1.4 mm (0.06 in.) / 1.4 mm (0.06 in.) |
| Engagement cushion method | | Cushion Springs |
| Release bearing type & method lub. | | Self Centering, Angular Contact Ball Bearing Pre-Packed & Sealed |
| Torsional damping method, springs, hysteresis | | Coil Springs With Non-Metal Friction Control |

* Includes shift linkage, lubricant, and clutch housing. If other specify.

MVMA Specifications

Vehicle Line BERETTA
 Model Year 1993 Issued 9-92 Revised _____

METRIC (U.S. Customary)

Engine Description
 Engine Code

2.3 LITER L4 (138 CID)
 MULTI-PORT FUEL INJECTION RPO LGO

Transmissions/Transaxle (Std., Opt., N.A.)

| | |
|--|----------------|
| Manual 4-speed (manufacturer/country) | |
| Manual 5-speed (manufacturer/country) | |
| Manual 6-speed (manufacturer/country) | |
| Automatic (manufacturer/country) | Not Applicable |
| Auto. overdrive (manufacturer/country) | |

Manual Transmission/Transaxle

| | | |
|-------------------------------------|------------------|-----------------------------------|
| Number of forward speeds | | 5 |
| Gear ratios | 1st | 3.50 |
| | 2nd | 2.05 |
| | 3rd | 1.38 |
| | 4th | 1.03 |
| | 5th | .72 |
| | 6th | |
| | Reverse | 3.41 |
| Synchronous meshing (specify gears) | | All Forward Gears |
| Shift lever location | | Floor - Console |
| Trans. case mat'l. & mass kg (lbs)* | | Aluminum, 30.314 (13.75) |
| Lubricant | Capacity L (pt.) | 1.9 (4.0) |
| | Type recommended | Standard Transmission Fluid (STF) |

Clutch (Manual Transmission)

| | | |
|---|--|---|
| Clutch manufacturer | | Daikin |
| Clutch type (dry, wet; single, multiple disc) | | Dry, Single |
| Linkage (hyd., cable, rod, lever, other) | | Hydraulic |
| Max. pedal effort (nom. spring load) N (lbs.) | Depressed | 151 (34) |
| | Released | 0 (0) |
| Assist (spring, power/percent, nominal) | | None |
| Type pressure plate springs | | Belleville Spring |
| Total spring load (nominal) N (lbs) | | 5892 (1325) |
| Clutch facing | Facing mfr. & mat'l. coding | Daikin NC80 |
| | Facing mat'l. & construction | NC80 |
| | Rivets per facing | 16 |
| | Outside x inside dia. (nom.) | 232 x 150 mm (9.13 x 5.91 in.) |
| | Total eff. area sq cm (sq in) | 442 (68.5) |
| | Thickness (pressure plate side/fly wheel side) | 3.2 (.126) Pressure Plate, 3.5 (.138) Fly Wheel |
| | Rivet depth (pressure plate side/fly wheel side) | 1.6 (.06) Pressure Plate, 1.5 (.06) Fly Wheel |
| Engagement cushion method | | Driven Plate Cushion |
| Release bearing type & method lub. | | Ball Thrust - Prepacked & Sealed |
| Torsional damping method, springs, hysteresis | | Coil Spring With Friction Washer |

* Includes shift linkage, lubricant, and clutch housing. If other specify.

MVMA Specifications

Vehicle Line BERETTA
 Model Year 1993 Issued 9-92 Revised _____

METRIC (U.S. Customary)

Engine Description 2.2 LITER L4 (133 CID)
 Engine Code MULTI-PORT FUEL INJECTION RPO LN2

Automatic Transmission/Transaxle

| | | |
|--|-------------------------------------|--|
| Trade Name | | 3T40 Transaxle Assembly |
| Type and special features (describe) | | 3-Speed Automatic, Fully Automatic Shifted Planetary Gear W/Torque Converter And Lock-Up Clutch |
| O Shift mechanics | | |
| Gear selector | Location (column, floor, other) | Floor |
| | Ltr./No. designation (e.g. PRND21) | P-R-N-D-2-1 |
| | Shift interlock (yes, no, describe) | No |
| Gear ratios | 1st | 2.84 |
| | 2nd | 1.60 |
| | 3rd | 1.00 (Converter Clutch Engagement) |
| | 4th | Not Applicable |
| | 5th | " |
| | 6th | " |
| | Reverse | 2.07 |
| Final drive ratio | | |
| Max. upshift vehicle speed - drive range km/h (mph) | | 2 - 3 = 130 (81) |
| O Max. upshift engine speed RPM | | |
| Max. kickdown speed - drive range km/h (mph) | | 3 - 2 = 124 (77) |
| Min. overdrive speed km/h (mph) | | --- |
| O Torque converter | | |
| Torque converter | Type | |
| | Torus design | |
| | Number of elements | 3 |
| | Max. ratio at stall | 2.48 |
| | Type of cooling (air, liquid) | Liquid |
| | Nominal diameter | 245 (9.8) |
| Capacity factor "K" TM | 203 | |
| O Pump type | | |
| Lubricant | Capacity refill L (pt.) | 8.5 (17.85) Dry Transmission, Original Filling |
| | Type recommended | Dexron II |
| Oil cooler (std., opt., N.A., internal, external, air, liquid) | | Standard, Integral Part Of Radiator |
| Trans. mass kg (lbs) & case matl.** | | 65.7 (144.54), Dry Weight |

All Wheel / 4 Wheel Drive

(NOT APPLICABLE)

| | | |
|--|--|--|
| Desc. & type (part-time, full-time, 2/4 shift while moving, mech., elect., chain/gear, etc.) | | |
| Transfer | Manufacturer and model | |
| | Type and location | |
| Low-range gear ratio | | |
| System disconnect (describe) | | |
| Center differential | Type (bevel, planetary, w or w/o viscous bias, torsen, etc.) | |
| | Torque split(% frt/rear) | |

* Input speed / square root of torque.
 ** Dry weight including torque converter. If other, specify.

MVMA Specifications

Vehicle Line BERETTA
 Model Year 1993 Issued 9-92 Revised _____

METRIC (U.S. Customary)

Engine Description **3.1 LITER V6 (191 CID)**
 Engine Code **MULTI-PORT FUEL INJECTION RPO LHO**

Automatic Transmission/Transaxle

| | | |
|--|-------------------------------------|--|
| Trade Name | | 3T40 Transaxle Assembly |
| Type and special features (describe) | | 3-Speed Automatic, Fully Automatic Shifted Planetary Gear W/Torque Converter And Lock-Up Clutch |
| O Shift mechanics | | |
| Gear selector | Location (column, floor, other) | Column & Floor |
| | Ltr./No. designation (e.g. PRND21) | P-R-N-D-2-1 |
| | Shift interlock (yes, no, describe) | No |
| Gear ratios | 1st | 2.84 |
| | 2nd | 1.60 |
| | 3rd | 1.00 (Converter Clutch Engagement) |
| | 4th | Not Applicable |
| | 5th | " |
| | 6th | " |
| | Reverse | 2.07 |
| Final drive ratio | | |
| Max. upshift vehicle speed - drive range km/h (mph) | | 2 - 3 = 130 (81) 2.84 Ratio 145 (90) 2.53 Ratio |
| O Max. upshift engine speed RPM | | |
| Max. kickdown speed - drive range km/h (mph) | | 3 - 2 = 126 (78) 138 (86) |
| Min. overdrive speed km/h (mph) | | -- |
| O Torque converter | | |
| Type | | |
| Torus design | | |
| Number of elements | | 3 |
| Max. ratio at stall | | 2.35 |
| Type of cooling (air, liquid) | | Liquid |
| Nominal diameter | | 245 (9.8) |
| Capacity factor "K" | | 177 |
| O Pump type | | |
| Lubricant | Capacity refill L (pt.) | 8.5 (17.85) Dry Transmission, Original Filling |
| | Type recommended | Dexron II |
| Oil cooler (std., opt., N.A., internal, external, air, liquid) | | Standard, Integral Part Of Radiator |
| Trans. mass kg (lbs) & case matl.** | | 65.7 (144.54) Dry Weight |

All Wheel / 4 Wheel Drive

(NOT APPLICABLE)

| | | |
|--|---|--|
| Desc. & type (part-time, full-time, 2/4 shift while moving, mech., elect., chain/gear, etc.) | | |
| Transfer | Manufacturer and model | |
| | Type and location | |
| Low-range gear ratio | | |
| System disconnect (describe) | | |
| Center differential | Type (bevel, planetary, w or w/o viscous bias, torsion, etc.) | |
| | Torque split(% frt/rear) | |

* Input speed / square root of torque.
 ** Dry weight including torque converter. If other, specify.

MVMA Specifications

Vehicle Line BERETTA
 Model Year 1993 Issued 9-92 Revised _____

METRIC (U.S. Customary)

| | |
|--------------------|-----------------------------------|
| Engine Description | 2.2 LITER L4 (133 CID) |
| Engine Code | MULTI-PORT FUEL INJECTION RPO LN2 |

| Axle Ratio and Tooth Combinations | | AUTOMATIC - MD9 | MANUAL - MR3 |
|---|----------------|-----------------|----------------|
| Effective final drive ratio (or overall top gear ratio) | | 3.18 | 3.83 (2.83) |
| Trnsfr ratio and method(chain,gear,etc) | | 1.12, Chain | Not Applicable |
| Front drive unit | Ring gear o.d. | Not Applicable | " |
| | No. of teeth | Pinion | " |
| | | Ring gear | " |

Front Drive Unit

| | | |
|--|-------------------------|---|
| Description (integral to trans., etc.) | | Planetary Final Drive Integral With Transmission |
| Limited slip differential(type) | | Not Applicable |
| Drive pinion | Type | " |
| | Offset | " |
| No. of differential pinions | | 2 |
| Pinion/differential | Adjustment (shim, etc.) | Not Applicable |
| | Bearing adjustment | " |
| Driving wheel bearing (type) | | |
| Lubricant | Capacity L (pt.) | See Automatic Trans Spec |
| | Type recommended | " |

Axle Shafts - Front Wheel Drive

| | | | | |
|---|--------------------------------|--|-----------------------|--|
| Manufacturer and number used | | Saginaw Division, 2 | | |
| Type (straight, solid bar, tubular, etc.) | Left | Straight, Solid Bar | | |
| | Right | Straight, Solid Bar | | |
| Outer diam. x length* x wall thickness | Manual transaxle | Left | 23.81 x 320.0 mm | |
| | | Right | 23.81 x 663.0 mm | |
| | Automatic transaxle | Left | 23.81 x 311.0 mm | |
| | | Right | 23.81 x 364.3 mm | |
| | Optional transaxle | Left | None | |
| | | Right | None | |
| Slp yoke | Type | None | | |
| | Number of teeth | None | | |
| | Spline o.d. | None | | |
| Universal joints | Make and mfg. no. | Inner | Saginaw Division | |
| | | Outer | Saginaw Division | |
| | Number used | | 2 On Each Drive Shaft | |
| | Type, size, plunge | Inner | Triplot 61.0 Stroke | |
| | | Outer | Rzeppa - Fixed Center | |
| | Attach (u-bolt, clamp, etc.) | | Splined | |
| Bearing | Type (plain, anti-friction) | Inner, Ball & Roller; Outer, Ball | | |
| | Lubrication (fitting, prepack) | Prepacked | | |
| Drive taken through (torque tube, arms or springs) | | Wishbone Lower Control Arm; Upper MacPherson Strut | | |
| Torque taken through (torque tube, arms or springs) | | Engine Mounting System | | |

* Centerline to centerline of universal joints, or to centerline of attachment.

MVMA Specifications

Vehicle Line BERETTA
 Model Year 1993 Issued 9-92 Revised(*) _____

METRIC (U.S. Customary)

Engine Description 3.1 LITER V6 (191 CID)
 Engine Code MULTI-PORT FUEL INJECTION RPO LHO

| Axle Ratio and Tooth Combinations | | AUTOMATIC - MD9 | MANUAL - MG2 |
|---|----------------|-----------------|----------------|
| Effective final drive ratio (or overall top gear ratio) | | 2.53 & 2.84 | 3.61 (2.60) |
| Transr ratio and method(chain, gear, etc) | | 1.00, Chain | Not Applicable |
| Front drive unit | Ring gear o.d. | Not Applicable | " |
| | No. of teeth | " | " |
| | Pinion | " | " |
| | Ring gear | " | " |

Front Drive Unit

| | | |
|--|-------------------------|---|
| Description (integral to trans., etc.) | | Planetary Final Drive Integral With Transmission |
| Limited slip differential (type) | | Not Applicable |
| Drive pinion | Type | " |
| | Offset | " |
| No. of differential pinions | | 2 |
| Pinion/differential | Adjustment (shim, etc.) | Not Applicable |
| | Bearing adjustment | " |
| Driving wheel bearing (type) | | See Automatic Trans Spec |
| Lubricant | Capacity L (pt.) | " |
| | Type recommended | " |

Axle Shafts - Front Wheel Drive

| | | | | |
|---|------------------------------|--|-------------------------|--------------------------|
| Manufacturer and number used | | 2 | | |
| Type (straight, solid bar, tubular, etc.) | Left | Straight Solid Bar | | |
| | Right | Straight Solid Bar | | |
| Outer diam. x length* x wall thickness | Manual transaxle | Left | 27.05 X 308.0 mm | |
| | | Right | 27.05 x 315.5 mm | |
| | Automatic transaxle | Left | 23.81 X 304.6 mm | |
| | | Right | 23.81 X 365.4 mm | |
| | Optional transaxle | Left | None | |
| | | Right | None | |
| Slip yoke | Type | None | | |
| | Number of teeth | None | | |
| | Spline o.d. | None | | |
| Universal joints | Make and mfg. no. | Inner | Saginaw Division | |
| | | Outer | Saginaw Division | |
| | Number used | 2 On Each Drive Shaft | | |
| | Type, size, plunge | Inner | FREE MOTION 61.0 Stroke | Cross-Groove 61.2 Stroke |
| | | Outer | Rzeppa - Fixed Center | |
| | Attach (u-bolt, clamp, etc.) | | Splined | |
| | Bearing | Type (plain, anti-friction) | Inner - Ball & Roller | Inner - Ball |
| | | Lubrication (fitting, prepack) | Outer - Ball | Outer - Ball |
| | | Prepacked | | |
| Drive taken through (torque tube, arms or springs) | | Wishbone Lower Control Arm; Upper MacPherson Strut | | |
| Torque taken through (torque tube, arms or springs) | | Engine Mounting System | | |

* Centerline to centerline of universal joints, or to centerline of attachment.

MVMA Specifications

Vehicle Line BERETTA
 Model Year 1993 Issued 9-92 Revised _____

METRIC (U.S. Customary)

| | |
|---------------------------|-----------------------------------|
| Engine Description | 2.3 LITER L4 (138 CID) |
| Engine Code | MULTI-PORT FUEL INJECTION RPO LGO |

Axle Ratio and Tooth Combinations **MANUAL - MV5 (Does Not Come With Base)**

| | | | |
|---|----------------|-----------|----|
| Effective final drive ratio (or overall top gear ratio) | | 3.94 | |
| Transfr ratio and method(chain,gear,etc) | | Gear | |
| Front drive unit | Ring gear o.d. | 202 (8.0) | |
| | No. of teeth | Pinion | 18 |
| | | Ring gear | 65 |

Front Drive Unit

| | | |
|--|-------------------------|---|
| Description (integral to trans., etc.) | | Planetary Final Drive Integral With Transmission |
| Limited slip differential (type) | | Not Applicable |
| Drive pinion | Type | " |
| | Offset | " |
| No. of differential pinions | | 2 |
| Pinion/differential | Adjustment (shim, etc.) | Shim |
| | Bearing adjustment | Not applicable |
| Driving wheel bearing (type) | | Sealed Ball Bearing (Integral Part Of Bolt In Hub Unit) |
| Lubricant | Capacity L (pt.) | 1.9 (4), Transaxle |
| | Type recommended | STF |

Axle Shafts - Front Wheel Drive

| | | | | |
|---|--------------------------------|--|--------------------------|--|
| Manufacturer and number used | | 2 | | |
| Type (straight, solid bar, tubular, etc.) | | Left | Straight, Solid Bar | |
| | | Right | Straight, Solid Bar | |
| Outer diam. x length* x wall thickness | Manual transaxle | Left | 27.1 x 308.0 mm | |
| | | Right | 27.1 x 315.5 mm | |
| | Automatic transaxle | Left | | |
| | | Right | | |
| | Optional transaxle | Left | None | |
| | | Right | None | |
| Slip yoke | Type | None | | |
| | Number of teeth | None | | |
| | Spline o.d. | None | | |
| Universal joints | Make and mfg. no. | Inner | Saginaw Division | |
| | | Outer | Saginaw Division | |
| | Number used | | 2 On Each Drive Shaft | |
| | Type, size, plunge | Inner | Cross-Groove 61.2 Stroke | |
| | | Outer | Rzeppa - Fixed Center | |
| | Attach (u-bolt, clamp, etc.) | | Splined | |
| Bearing | Type (plain, anti-friction) | Inner - Ball Outer - Ball | | |
| | Lubrication (fitting, prepack) | Prepacked | | |
| Drive taken through (torque tube, arms or springs) | | Wishbone Lower Control Arm; Upper MacPherson Strut | | |
| Torque taken through (torque tube, arms or springs) | | Engine Mounting System | | |

* Centerline to centerline of universal joints, or to centerline of attachment.

MVMA Specifications

Vehicle Line BERETTA
 Model Year 1993 Issued 9-92 Revised(*) _____

METRIC (U.S. Customary)

Model Code/Description And/Or
 Engine Code/Description

BASE

Suspension - General Including Electronic Controls

| | | | |
|---------------------------------|---|--|----|
| Car leveling | Std./opt./n.a. | -- | |
| | Manual/automatic control | -- | |
| | Type (air/hydraulic) | -- | |
| | Primary/assist spring | -- | |
| | Rear only/4 wheel leveling | -- | |
| | Single/dual rate spring | -- | |
| | Single/dual ride heights | -- | |
| | Provision for jacking | Body Jack & Pads On Rocker | |
| Shock absorber damping controls | Std./opt./n.a. | -- | |
| | Manual/automatic control | -- | |
| | Number of damping rates | -- | |
| | Type of actuation (manual/electric motor/air, etc.) | -- | |
| | s e n s o r s | Lateral acceleration | -- |
| | | Deceleration | -- |
| | | Acceleration | -- |
| Road surface | | -- | |
| Shock absorber (front & rear) | Type | Front: MacPherson Strut, Rear: Double Acting Hydraulic | |
| | Make | Delco Products | |
| | Piston diameter | Front: 32 (1.26) Rear: 32 (1.26) | |
| | Rod diameter | Front: 22 (.87) Rear: 13 (.51) | |

Suspension - Front

| | | |
|----------------------|---|---|
| Type and description | | MacPherson Strut With Coil Spring |
| Travel | Full jounce (define load condition) | 82 mm (3.23 in.), From Design |
| | Full rebound | 81 mm (3.19 in.), From Design |
| Spring | Type (coil, leaf, other & matl) | Coil, Steel |
| | Insulators (type & matl) | Top & Bottom - Rubber |
| | Size (Leaf: length & width; Coil: design height & i.d.; Bar: length & diameter) | Spring Computer Selected - Varies With Option Content |
| | Spring rate N/mm (lb./in.) | 20 (177) |
| | Rate @ wheel N/mm (lb./in.) | 17.5 (154.9) |
| Stabilizer | Type (link, linkless, frmlless) | Link |
| | Material & O.D. bar/tube, wall thickness | Steel, 30 mm (1.18 in.) |

Suspension - Rear

| | | |
|------------------------|---|--|
| Type and description | | Trailing Twist Axle With Tubular Control Arms And Open Section Transverse Beam |
| Travel | Full jounce (define load condition) | 100.8 mm (3.97 in.), From Design |
| | Full rebound | 91 mm (3.58 in.), From Design |
| Spring | Type (coil, leaf, other & matl) | Coil, Steel |
| | Size (Leaf: length & width; Coil: design height & i.d.; Bar: length & diameter) | Spring Computer Selected - Varies With Option Content |
| | Spring rate N/mm (lb./in.) | 23 (203.6), Variable |
| | Rate @ wheel N/mm (lb./in.) | 11.1 (98.2), Variable |
| | Insulators (type & material) | Top & Bottom - Rubber |
| | If leaf | No. of leaves |
| Shackle (comp or tens) | | -- |
| Stabilizer | Type (link, linkless, frmlless) | -- |
| | Material & O.D. bar/tube, wall thickness | -- |
| Track bar (type) | | -- |

MVMA Specifications

METRIC (U.S. Customary)

Vehicle Line BERETTA
 Model Year 1993 Issued 9-92 Revised(*) _____

Model Code/Description And/Or
 Engine Code/Description
Brakes - Service

ALL

| | | | | | |
|---|-------------------------------------|--|---|--|--|
| Description | | Power Assisted Hydraulic Brakes | | | |
| Manufacturer and brake type (std., opt., n.a.) | Front (disc or drum) | Standard - Disc | | | |
| | Rear (disc or drum) | Standard - Drum | | | |
| Valving type(prop.,delay,metering,other) | | Proportioning, Diagonal Split Circuit | | | |
| Power brake (std., opt., n.a.) | | Standard | | | |
| Booster type(rmt,intgrl,vac.,hyd.,etc.) | | Tandem Vacuum | | | |
| Vacuum | Source (inline, pump, etc.) | Inline | | | |
| | Reservoir (volume cu. in.) | None | | | |
| | Pump-type | Not Applicable | | | |
| O Traction assist | Operational speed range | Not Applicable | | | |
| | Type (engine or brake intervention) | | | | |
| Anti-lock device | Front/rear (std., opt., n.a) | Standard | | | |
| | Manufacturer | Delco Chassis Division | | | |
| | Type (electronic, mech.) | Electronic | | | |
| | Number sensors or circuits | 4 | | | |
| | No. anti-lock hyd. circuits | 3 | | | |
| | Integral or add-on system | Add-On | | | |
| | Yaw control (yes, no) | Yes | | | |
| Hydraulic power source | | No | | | |
| Effective area sq. cm. (sq. in.)* | | 204 (31.7) Front | 614 (95.2) Rear | | |
| Gross Lng area sq cm (sq in)** (F/R) | | 204 (31.7) Front | 650 (100.8) Rear | | |
| Swept area sq cm (sq in)*** (F/R) | | 1175 (182.2) Front | 556 (86.2) Rear | | |
| Rotor | Outer working diameter | F/R | Front - 259.5(10.2) | | |
| | Inner working diameter | F/R | | | |
| | Thickness | F/R | Front - 20 (.79) | | |
| | Mati & type (vented/sld) | F/R | Front - Vented Cast Iron | | |
| Drum | Diameter & width | F/R | Rear - 200 x 45 mm (7.87 x 1.77 in.) | | |
| | Type and material | F/R | Cast Iron | | |
| Wheel cylinder bore | | Front - 57 mm (2.24 in.) Rear - 17.5 (.69) | | | |
| Master cylinder | Bore/stroke | F/R | Bore - 22.2 mm (.874 in.) Stroke 35.7 mm (1.41 in.) | | |
| Pedal arc ratio | | 3.35:1 | | | |
| Line pressure at 445 N (100 lb.) pedal load kPa (psi) | | (1,600) Max | | | |
| Lining clearance | | F/R | Both - Self Adjusting | | |
| Brake lining | Front wheel | Bonded or riveted | | Integrally Molded - Inboard And Outboard | |
| | | Rivet size | | Not Applicable | |
| | | Manufacturer | | Delco Chassis Division | |
| | | Lining code ***** | | 128 FE | |
| | | Material | | Semi-Metallic | |
| | | **** | Pri. or out-brd | 124 x 46 x 8.6 (4.88 x 1.81 x .34) | |
| | | Size | Sec. or in-brd | 124 x 46 x 9.7 (4.88 x 1.81 x .38) | |
| | Shoe thcknss.(no lng) | | 4.85 (.19) | | |
| | Rear wheel | Bonded or riveted | | Riveted | |
| | | Manufacturer | | Delco Chassis Division | |
| | | Lining code ***** | | 235 FE | |
| | | Material | | Organic | |
| | | **** | Pri. or out-brd | 167.7 x 43.9 x 6 mm (6.602 x 1.728 x .236 in.) | |
| | | Size | Sec. or in-brd | 194 x 43.9 x 7 mm (7.638 x 1.728 x .28 in.) | |
| Shoe thcknss (no lng) | | 2.75 mm (.11 in.) | | | |

* Excludes rivet holes, grooves, chamfers, etc. **Includes rivet holes, grooves, chamfers, etc.
 *** Total swept area for four brakes. (Drum brake: Widest lining contact width for each brake x its contact circum.)
 (Disc brake: Square of Outer Working Dia. - Square of inner Working Dia. X Pi/2 for each brake.)
 **** Size for drum brakes includes length x width x thickness.
 ***** Manufacturer I.D., catalog for formulation designation and coefficient of friction classification.

MVMA Specifications

Vehicle Line BERETTA
 Model Year 1993 Issued 9-92 Revised(*) _____

METRIC (U.S. Customary)

Model Code/Description And/Or
 Engine Code/Description

BASE

Tires And Wheels (Standard)

| | | | | |
|----------------------------|--------|---|---------------------------|---|
| O | Tires | Size (service description) | | P185/75R14 BW |
| | | Type (bias, radial, etc.) | | Steel Belted Radial |
| | | Inflation pressure (cold) for recommended max. vehicle load | Front kPa (psi) | 210 (30) |
| | | | Rear kPa (psi) | 210 (30) |
| Rev/mile—at 70 km/h(45mph) | | | | |
| O | Wheels | Type & material | | Steel |
| | | Rim (size & flange type) | | 14 x 6 |
| | | Wheel offset | | 47 (1.85) |
| | | Attachment | Type (bolt or stud & nut) | Stud |
| | | | Circle diameter | 100.0 mm (3.94 in.) |
| Number & size | | 5-M12 x 1.5 - 6H, THD. (Metric) | | |
| O | Spare | Tire and wheel | | T115/70D - 14 BW, Wheel Dia. 14 x 4, Inflation 415 (60) |
| | | Storage position & location (describe) | | Flat Under Rear Load Floor |

Tires And Wheels (Optional)

| | | |
|--|---|---------------------|
| O | Tire size (service description) | P195/70R14 BW |
| | Type (bias, radial, steel, nylon, etc.) | Steel Belted Radial |
| | Wheel (type & material) | Steel |
| | Rim (size, flange type and offset) | 14 x 6 |
| O | Tire size (service description) | P205/60R15 BW |
| | Type (bias, radial, steel, nylon, etc.) | Steel Belted Radial |
| | Wheel (type & material) | Aluminum |
| O | Rim (size, flange type and offset) | 15 x 7 |
| | Tire size (service description) | P205/55VR16 BW |
| | Type (bias, radial, steel, nylon, etc.) | Steel Belted Radial |
| O | Wheel (type & material) | Aluminum |
| | Rim (size, flange type and offset) | 16 x 7 |
| | Tire size (service description) | P205/55R16 BW |
| O | Type (bias, radial, steel, nylon, etc.) | Steel Belted Radial |
| | Wheel (type & material) | Aluminum |
| | Rim (size, flange type and offset) | 16 x 7 |
| Spare tire and wheel size | | |
| (if configuration is different than road tire or wheel, describe optional spare tire and/or wheel location & storage position) | | |

Brakes - Parking

| | | |
|---------------------------------|--|--------------------------------|
| Type of control | | Hand Lever Assembly |
| Location of control | | In Console Between Front Seats |
| Operates on | | Rear Service Brakes |
| If separate from service brakes | Type (internal or external) | -- |
| | Drum diameter | -- |
| | Lining size (length x width x thickness) | -- |

MVMA Specifications

Vehicle Line BERETTA
 Model Year 1993 Issued 9-92 Revised _____

METRIC (U.S. Customary)

Model Code/Description And/Or
 Engine Code/Description

BASE

Steering

| | | | | |
|--|---|------------------------|---|----------------------------|
| Manual (std., opt., n.a.) | | Not Available | | |
| Power (std., opt., n.a.) | | Standard | | |
| Speed-sensitive (std., opt., n.a.) | | Not Available | | |
| 4-wheel steering (std., opt., n.a.) | | Not Available | | |
| Adjustable steering wheel/ column (tilt, telescope, other) | Type | Tilt | | |
| | Manufacturer | Saginaw Division | | |
| | (std., opt., n.a.) | Optional | | |
| Wheel diameter ** (W9) SAE J1100 | Manual | -- | | |
| | Power | 386 (15.2) | | |
| Turning diameter m (ft.) | Out-side front | Wall to wall (l. & r.) | 11.3 (37.2) | |
| | | Curb to curb (l. & r.) | 10.75 (35.3) | |
| | In-side rear | Wall to wall (l. & r.) | 5.8 (19.2) | |
| | | Curb to curb (l. & r.) | 7.5 (24.6) | |
| Scrub Radius * | | -1.69 (14" Tires) | | |
| Manual | Gear | Type | -- | |
| | | Manufacturer | -- | |
| | | Ratios | Gear -- Overall -- | |
| | No. wheel turns(stop to stop) | | -- | |
| | Type (coaxial, elec. hyd., etc.) | | Rack And Pinion W/Center Take-Off Tie Rods - Integral | |
| Power | Manufacturer | | Saginaw Division | |
| | Gear | Type | Rack And Pinion W/Center Take-Off Tie Rods - Integral | |
| | | Ratios | Gear -- Overall 16.12:1 | |
| | | Pump (drive) | | Belt Off Crankshaft Pulley |
| | No. wheel turns(stop to stop) | | 2.88 | |
| Linkage | Type | | Center Take Off Tie Rods, Rack And Pinion | |
| | Location (front or rear of wheels, other) | | Rear | |
| | Tie Rods (one or two) | | 2 | |
| Steering axis | Inclination at camber (deg.) | | 13.2 | |
| | Bear-ings (type) | Upper | Ball Bearings | |
| | | Lower | Ball Joint | |
| | | Thrust | Incorporated In Upper Bearing | |
| Steering spindle/knuckle & joint type | | MacPherson Strut | | |

* The horizontal distance in the front elevation between wheel centerline and kingpin (ball joint) axis at ground.
 ** See Page 22.

MVMA Specifications

METRIC (U.S. Customary)

Vehicle Line BERETTA
 Model Year 1993 Issued 9-92 Revised(*)

Model Code/Description And/Or
 Engine Code/Description

BASE

Wheel Alignment

| Wheel | Service | Parameter | Value |
|--------------------------------|--------------------------|---------------------------------|----------------|
| Front wheel at curb mass (wt.) | Service checking | Caster (deg.) | Not Adjustable |
| | | Camber (deg.) | 0 (+/-) .7 |
| | | Toe-in outside track - mm (in.) | 0 (+/-) .10 |
| | Service reset* | Caster (deg.) | Not Adjustable |
| | | Camber (deg.) | 0 (+/-) .7 |
| | | Toe-in - mm(in.) | 0 (+/-) .10 |
| | Periodic M.V. inspection | Caster (deg.) | Not Adjustable |
| | | Camber (deg.) | --- |
| | | Toe-in - mm(in.) | --- |
| Rear wheel at curb mass (wt.) | Service checking | Camber (deg.) | Not Applicable |
| | | Toe-in outside track - mm (in.) | " |
| | Service reset* | Camber (deg.) | " |
| | | Toe-in - mm(in.) | " |
| | Periodic M.V. inspection | Camber (deg.) | " |
| | | Toe-in - mm(in.) | " |

* Indicates pre-set, adjustable, trend set or other.

Electrical - Instruments and Equipment

| | | ELECTRIC BASE CLUSTER | OPTIONAL ELECTRIC CLUSTER |
|--|---|---|---------------------------|
| Speedometer | Type (analog, digital, std., opt.) | Analog | |
| | Trip odometer (std., opt., n.a.) | Not Available | Standard |
| Head-up display | Std., opt., not avail. | Not Available | |
| | Type - Secondary, Opto-electronic | " | |
| | Speedometer | Digital | " |
| | Status/warn. indicators - Turn signals, high beam, low fuel, check gauges | " | |
| | Brightness control | Day/night mode, adj. | " |
| EGR maintenance indicator | | Not Available | |
| Charge indicator | Type | Tell-Tale Warning Light | Gauge |
| | Warning device (light, audible) | Light | Not Available |
| Temperature indicator | Type | Gauge | |
| | Warning device | Tell-Tale Warning Light | |
| Oil pressure indicator | Type | Tell-Tale Warning Light | Gauge |
| | Warning device | Light | |
| Fuel indicator | Type | Electric Gauge W/Pointer | |
| | Warning device | Not Available | |
| Windshield wiper | Type (standard) | Electric 2-Speed | |
| | Type (optional) | Intermittent Windshield Wiper Sys. | |
| | Blade length | 482.6 mm (19.0 in.) | |
| | Swept area sq cm (sq in) | 6221.9 (964.4) | |
| Windshield washer | Type (standard) | Wet-Arm Electric Pump Mounted On Reservoir Bottle | |
| | Type (optional) | Not Available | |
| | Fluid level indicator | " | |
| Rear window wiper, wiper/washer (std., opt., n.a.) | | " | |
| Horn | Type | Electric Vibrating | |
| | Number used | Two ('A' And 'F' Notes) | |
| Other | Headlamp-on Warning | Standard, Chimes | |

MVMA Specifications

Vehicle Line BERETTA
 Model Year 1993 Issued 9-92 Revised _____

METRIC (U.S. Customary)

Engine Code/Description

2.2 LITER L4 (133 CID)
 MULTI-PORT FUEL INJECTION RPO LN2

Electrical - Supply System

| | | |
|------------|----------------------------|------------------------------|
| Battery | Manufacturer | Delco Remy |
| | Model, std., (opt.) | 1982514 1983646, Opt. |
| | Voltage | 12 |
| | Amps at 0 deg F cold crnk | 525 600 |
| | Minutes-reserve capacity | 90 |
| | Amps/hrs. - 20 hr. rate | 54 |
| | Location | Engine Compartment |
| Alternator | Manufacturer | Delco Remy |
| | Rating (idle/max. rpm) | 42/105 |
| | Ratio (alt. crank/rev.) | 2.64:1 |
| | Output at idle (rpm, park) | 42 Amps @ 27 Deg. C. 600 RPM |
| Regulator | Type | Integral With Alternator |
| | Optional (type & rating) | |

Electrical - Starting System

| | | |
|-------------|-----------------------------------|-------------------------------|
| Motor | Manufacturer | Delco Remy |
| | Curr.dr. -29 (-20) deg C (F) | 329 Amps |
| | Power rating kw (hp) | 1.4 (1.9) |
| Motor drive | Engagement type | Solenoid Operated Shift Lever |
| | Pinion engages from (front, rear) | Front |

Electrical - Ignition System

| | | | |
|-------------|---|---|-----------------------------|
| Type | Electronic (std., opt., n.a.) | Electronic Direct Ignition (Std.) - Control Module With Two Integral Coils And One Remote Timing Sensor | |
| | Other (specify) | -- | |
| Coil | Manufacturer | Delco Remy | |
| | Model | 1103902 | |
| | Current | Engine stopped-A | Less Than 100 ma |
| | | Engine idling - A | Less Than 1.5 Amp (Average) |
| Spark plug | Manufacturer | AC Spark Plug | |
| | Model | R44LTSMA | |
| | Thread (mm) | 14 x 1.25 | |
| | Tightening torque Newton meters (lb. ft.) | 10-20 (7-15) | |
| | Gap | 1.14 (0.045) | |
| Distributor | Number per cylinder | 1 | |
| | Manufacturer | Not Applicable | |
| | Model | " | |

Electrical - Suppression

| | |
|------------------|---------------|
| Locations & type | Not Available |
|------------------|---------------|

MVMA Specifications

Vehicle Line BERETTA
 Model Year 1993 Issued 9-92 Revised _____

METRIC (U.S. Customary)

Engine Code/Description

3.1 LITER V6 (191 CID)
 MULTI-PORT FUEL INJECTION RPO LHO

Electrical - Supply System

| | | | |
|------------|----------------------------|------------------------------|--------------|
| Battery | Manufacturer | Delco Remy | |
| | Model, std., (opt.) | 1982514 Std. | 1983646 Opt. |
| | Voltage | 12 | |
| | Amps at 0 deg F cold crnk | 525 | 600 |
| | Minutes-reserve capacity | 90 | |
| | Amps/hrs. - 20 hr. rate | 54 | |
| | Location | Engine Compartment | |
| Alternator | Manufacturer | Delco Remy | |
| | Rating (idle/max. rpm) | 36/100 | |
| | Ratio (alt. crank/rev.) | 2.65 | |
| | Output at idle (rpm, park) | 66 Amps @ 27 Deg. C. 850 RPM | |
| | Optional (type & rating) | | |
| Regulator | Type | Integral With Alternator | |

Electrical - Starting System

| | | | |
|-------------|-----------------------------------|-------------------------------|--|
| Motor | Manufacturer | Delco Remy | |
| | Curr.dr. -29 (-20) deg C (F) | 350 Amps | |
| | Power rating kw (hp) | 1.4 (1.9) | |
| Motor drive | Engagement type | Solenoid Operated Shift Lever | |
| | Pinion engages from (front, rear) | Front | |

Electrical - Ignition System

| | | | | |
|-------------|---|---|-----------------------------|--|
| Type | Electronic (std., opt., n.a.) | Electronic Direct Ignition (Std.) - Control Module With Three Integral Coils And One Remote Timing Sensor | | |
| | Other (specify) | -- | | |
| Coil | Manufacturer | Delco Remy | | |
| | Model | 1103759 | | |
| | Current | Engine stopped-A | Less Than 100 ma | |
| | | Engine idling - A | Less Than 1.5 Amp (Average) | |
| Spark plug | Manufacturer | AC/Rochester Products | | |
| | Model | R44LTSM | | |
| | Thread (mm) | 14 x 1.25 | | |
| | Tightening torque Newton meters (lb. ft.) | 9-20 (7-15) | | |
| | Gap | 1.14 (0.045) | | |
| | Number per cylinder | 1 | | |
| Distributor | Manufacturer | Not Applicable | | |
| | Model | " | | |

Electrical - Suppression

| | |
|------------------|---------------|
| Locations & type | Not Available |
|------------------|---------------|

MVMA Specifications

Vehicle Line BERETTA
 Model Year 1993 Issued 9-92 Revised(*) _____

METRIC (U.S. Customary)

Engine Code/Description

2.3 LITER L4 (138 CID)
 MULTI-PORT FUEL INJECTION RPO LGO

Electrical - Supply System

| | | |
|------------|----------------------------|------------------------------|
| Battery | Manufacturer | Delco Remy |
| | Model, std., (opt.) | Standard |
| | Voltage | 12 |
| | Amps at 0 deg F cold crnk | 600 |
| | Minutes-reserve capacity | 90 |
| | Amps/hrs. - 20 hr. rate | 54 |
| | Location | Engine Compartment |
| Alternator | Manufacturer | Delco Remy |
| | Rating (idle/max. rpm) | 36/100 |
| | Ratio (alt. crank/rev.) | 2.08 |
| | Output at idle (rpm, park) | 68 Amps @ 27 Deg. C. 900 RPM |
| | Optional (type & rating) | None |
| Regulator | Type | Integral With Alternator |

Electrical - Starting System

| | | |
|-------------|-----------------------------------|-----------------------------|
| Motor | Manufacturer | Delco Remy |
| | Curr.dr. -29 (-20) deg.C(F) | 378 Amps |
| | Power rating kw (hp) | 1.5 kw |
| Motor drive | Engagement type | Solenoid With Postive Shift |
| | Pinion engages from (front, rear) | Front |

Electrical - Ignition System

| | | | |
|-------------|---|--|----------------|
| Type | Electronic (std, opt,n.a.) | Standard/Direct Ignition System | |
| | Other (specify) | Composite Unit W/2 Coils & Elect. Cnt. | |
| Coil | Manufacturer | Delco Remy (2) | |
| | Model | | |
| | Current | Engine stopped-A | 300 MA |
| | | Engine idling - A | Peak 8.25 Amps |
| Spark plug | Manufacturer | A/C Spark Plug | |
| | Model | .FR2LSK | |
| | Thread (mm) | 14 x 1.25 | |
| | Tightening torque Newton meters (lb. ft.) | 21 - 24 (15 - 18) | |
| | Gap | .889 mm (.035 in.) | |
| | Number per cylinder | 1 | |
| Distributor | Manufacturer | Not Applicable | |
| | Model | " | |

Electrical - Suppression

| | |
|------------------|---------------|
| Locations & type | Not Available |
|------------------|---------------|

MVMA Specifications

Vehicle Line BERETTA
 Model Year 1993 Issued 9-92 Revised _____

METRIC (U.S. Customary)

Model Code/Description

BASE

Body

| | |
|-------------------------------|--|
| Structure | Unitized Body Construction Including Front End Structure With Bolted-On Fenders And Hood. |
| Bumper system front - rear | Bumper Fascias Are Attached To Steel Impact Bar And Dual Energy Absorbers For Collision Energy Absorption. (Meets G.M. 5 mph Impact Standard) |
| Anti-corrosion treatment | Special Anti-Corrosion Materials Are Used On Interior And Exterior Metal Panel Surfaces. Materials Include One And Two-Sided Galvanized Steel, Special Metal Conditioners, Primers, And Sealers. Protective Moldings Are Applied To Exterior Lower Body. |

Body - Miscellaneous Information

| | | | |
|---|---|---|--------------------------------|
| Type of finish (lacquer, enamel, other) | High Solids Basecoat/Clearcoat Enamel | | |
| Hood | Material & mass | Two Sided Galvanized Steel, 17.91 kg. (39.5 lbs.) | |
| | Hinge location (front, rear) | Rear | |
| | Type (counterbalance, prop) | Prop | |
| | Release control (int., ext.) | Internal | |
| Trunk lid | Material & mass | Two Sided Galvanized Steel, 10.6 kg. (23.4 lbs.) | |
| | Type (counterbalance, other) | Torsion Rods | |
| | Internal release control (elec., mech., n.a.) | Electrical - Optional | |
| Hatch-back lid | Material & mass | Not Applicable | |
| | Type (counterbalance, other) | " | |
| | Internal release control (elec., mech., n.a.) | " | |
| Tailgate | Material & mass | " | |
| | Type (drop, lift, door) | " | |
| | Internal release control (elec., mech., n.a.) | " | |
| Vent window control (crank, friction, pivot, power) | Front | None | |
| | Rear | " | |
| Window regulator type (cable, tape, flex drive, etc.) | Front | Not Applicable | Elec. Pinion Gear & Sector Arm |
| | Rear | " | Elec. Pinion Gear & Sector Arm |
| Seat cushion type (e.g., 60/40, bucket, bench wire, foam, etc.) | Front | Bucket With Polyurethane Padding | |
| | Rear | Bench With Polyurethane Padding | |
| | 3rd seat | Not Applicable | |
| Seat back type (e.g., 60/40, bucket, bench, wire, foam, etc.) | Front | Reclining Bucket With Polyurethane Padding | |
| | Rear | Fixed Bench With Polyurethane Padding* | |
| | 3rd seat | Not Applicable | |

* For Beretta GT & GTZ, 60/40 Split Folding Rear Seat Standard

Frame

| | |
|---|--|
| Type and description (separate frame, unitized frame, partially-unitized frame) | Unitized Frame Body-Frame Integral With Bolt-On Powertrain Cradle |
|---|--|

MVMA Specifications

Vehicle Line BERETTA
 Model Year 1993 Issued 9-92 Revised _____

METRIC (U.S. Customary)

Model Code/Description

BASE

Restraint System

| Seating Position | | | Left | Center | Right |
|------------------|---|-------------|--------------------------|---|----------------|
| Active | Type & description (lap & shoulder belt, lap belt, etc.) | First seat | 3-Point Manual (Air Bag) | | 3-Point Manual |
| | | Second seat | 3-Point Belt | Adjustable latch 2-Point Belt (Non-Retractor) | 3-Point Belt |
| | Standard/optional | Third seat | | | |
| Passive | Type & description (air bag, motorized-2-point belt, fixed belt, knee bolster, manual-lap belt) | First seat | Air Bag | | |
| | | Second seat | | | |
| | Standard/optional | Third seat | | | |

| Glass | | SAE Ref No. |
|--|----|--------------|
| Windshield glass exposed surface area sq. cm. (sq. in.) | S1 | 10303 (1598) |
| Side glass exposed surface area sq. cm. (sq. in.) - total 2-sides | S2 | 1794 (278) |
| Backlight glass exposed surface area sq. cm. (sq. in.) | S3 | 4813 (746) |
| Total glass exposed surface area sq. cm. (sq. in.) | S4 | 16910 (2622) |
| <input type="radio"/> Windshield glass (type/thickness) | | Laminated |
| <input type="radio"/> Side glass (type/thickness) | | Tempered |
| <input type="radio"/> Backlight glass (type/thickness) | | Tempered |
| <input type="radio"/> Tinted (yes/no, location) | | |
| <input type="radio"/> Solar control (yes/no, coated/batched, location) | | |

Headlamps

| | |
|--|--|
| Description - sealed beam, halogen, replaceable bulb, etc. | Halogen, Replaceable Bulb - 2 Lamps - 2 Bulbs Each |
| Shape | Rectangular |
| Lo-beam type (2A1, 2B1, 2C1, etc.) | HB4 |
| Quantity | 2 |
| Hi-beam type (1A1, 2A1, 1C1, 2C1, etc.) | HB3 |
| Quantity | 2 |

MVMA Specifications

Vehicle Line BERETTA
 Model Year 1983 Issued 9-82 Revised _____

METRIC (U.S. Customary)

Engine Code/Description

BASE

Climate Control System

| | | |
|---|--------------------------|---|
| Air conditioning (std., opt., man., auto.) | | Optional With Manual Operation And Electrically Operated Temperature Door |
| Condenser | Type | Tube And Fin |
| | Eff. face area (sq. mm.) | 262,080 |
| | Fins per inch | 17 |
| Evaporator | Type | 3-5-5 Parallel Rib "S" Flow Plate Type, Round Tank |
| | Eff. face area (sq. mm.) | 45,212 |
| | Fins per inch | 14 |
| Heater Core | Material | Aluminum |
| | Eff. face area (sq. mm.) | 29,210 |
| | Fins per inch | 38 |
| Compressor | Type | V6 (Five Cylinder, Variable Displacement) |
| | Displacement (cc) | 136 (8.3); Optional Engine, 147 (9.2) |
| | Manufacturer | Harrison Division |
| | A/C pulley ratio | 1.24 |
| Accumulator | Type | None |
| | Height (mm.) | None |
| | Diameter (mm.) | None |
| Receiver | Type | Aluminum R-12 Desiccant |
| | Height (mm.) | 169 (6.7) |
| | Diameter (mm.) | 77 (3.0) |
| Refrigerant control (CCOT, TVS, etc.) | | TXV |
| Heater water valve (yes / no) | | No |
| Refrigerant (R - 12, R - 134a, etc.) | | R-12 |
| Charge level (lbs. - oz.) | | 2.63 lbs. |
| Cold engine lockout switch (yes / no) | | Yes |
| Wide open throttle cutout switch (yes / no) | | Yes |

MVMA Specifications

Vehicle Line BERETTA
 Model Year 1993 Issued 9-92 Revised(*)

METRIC (U.S. Customary)

Model Code/Description

BASE

Convenience Equipment (standard, optional, n.a.)

| | | |
|------------|---|---|
| | Clock (digital, analog) | Digital (Integ. W/Stereo Radios) |
| | Compass / thermometer | Not Available |
| | Console (floor, overhead) | Optional, (D55) Full Floor |
| O | Defroster, electric windshield | |
| | Defroster, electric backlight | Optional (C49) |
| Electronic | Diagnostic monitor (integrated, individual) | Not Available |
| | Instrument cluster (list instruments) | Optional (UB3) Oil Pressure, Temp, Volts, Trip Odom & Tack Standard (UH6) Temp |
| | Keyless entry | |
| | Tripminder (avg. spd. fuel) | |
| | Voice alert (list items) | |
| | Other | |
| | Fuel door lock (remote, key, electric) | Not Available |
| Lamps | Auto head on/off delay, dimming | " |
| | Cornering | " |
| | Courtesy (map, reading) | Standard, Map Reading Optional (DC4) |
| | Door lock, ignition | Not Available |
| | Engine compartment | " |
| | Fog | Standard On LZ (T96) |
| | Glove compartment | Not Available |
| | Trunk | Standard |
| | Illuminated entry system (list lamps, activation) | |
| | Other | Ash Tray Lamp Standard |
| Mirrors | Day / night (auto. man.) | Optional (DC4) (Manual) |
| | L.H. (remote, pwr., heated) | Standard (D68) Remote |
| | R.H.(convex, rmt, pwr, htd) | Standard (D68) Remote |
| | Visor vanity (RH/LH illum.) | Optional |
| | Navigation system (describe) | Not Available |
| | Prkg. brake-auto release (warn. light) | Standard (Manual Release) Lower Area Of Speedometer |

** - Available In Optional Custom Interior (RPO B18)

MVMA Specifications

Vehicle Line BERETTA
 Model Year 1993 Issued 9-92 Revised(*)

METRIC (U.S. Customary)

Model Code/Description

BASE

Convenience Equipment (standard, optional, n.a.)

| | | | |
|---|---|---|---|
| Power equipment | Deck lid(release, pull down) | | Optional (A90) Power Release |
| | Door locks (manual, auto., describe system) | | Optional (AU3) Power |
| | Seats | 2 - 4 - 6 way, etc. | Not Available |
| | | Reclining(R.H., L.H.) | " |
| | | Memory (R.H., L.H., preset, recline) | " |
| | | Support (lumbar, hip, thigh, etc.) | " |
| | | Heated (R.H., L.H., other) | " |
| | Side windows | | Optional (A31) |
| | Vent windows | | Not Available |
| | Rear windows | | " |
| Radio systems | Antenna (location, whip, w/shield, power) | | Front Fender - R.H., Fixed Mast Standard |
| | Stan. | | (UM7) Electronically Tuned AM/FM Stereo Radio With Seek And Scan And Clock. Included Dual Front And Extended Range Rear Speakers. |
| | Opt. | AM, FM, stereo, tape, compact disc, graphic equalizer, theft deterrent, radio prep package, headphone jacks, etc. | (UM6) AM/FM Stereo Cassette, Seek And Scan And Clock. |
| | | | (U1C) AM/FM Stereo, Seek/Scan, Clock, ETR & Compact Disc. |
| | Speaker (number, location) | | (U79) 4 Speakers; 2 In Front And Two In Rear |
| Roof: open air or fixed (flip-up, sliding, 'T') | | | (AD3) Optional Hinged Removable |
| Speed control device | | | (K34) Optional |
| Speed warn. dev. (light, buzzer, etc.) | | | Not Available |
| Tachometer (rpm) | | | (UB3) Optional |
| Telephone system (describe) | | | Not Available |
| Theft deterrent system | | | |

Trailer Towing

| | | |
|---------------------------------|-----------|-----------|
| Towing capable | Yes / No | Yes |
| Engine/transmission/axle | Std / Opt | LGO Opt. |
| Tow class (I, II, III)* | Std / Opt | |
| Max. gross trailer wgt. (lbs.) | Std / Opt | 1000 lbs. |
| Max. trailer tongue load (lbs.) | Std / Opt | 100 lbs. |
| Towing package available | Yes / No | No |

* Class I - 2,000 lbs. Class II - 3,500 lbs. Class III - 5,000 lbs.

MVMA Specifications

Vehicle Line BERETTA
 Model Year 1993 Issued 9-92 Revised _____

METRIC (U.S. Customary)

Vehicle Dimensions See Key Sheets for definitions

All dimensions to ground are for comparative purposes only. Dimensions are to be shown for all base body models of each vehicle line. SAE Ref. no. refers to the definition published in SAE Recommended Practice J1100 'Motor Vehicle Dimensions,' unless otherwise specified.

Model Code/Description

BASE

| Width | SAE Ref. No. | |
|----------------------------------|--------------|----------------|
| Tread (front) | W101 | 1417 (55.8) |
| Tread (rear) | W102 | 1438 (56.6) |
| Vehicle width | W103 | 1724 (67.9) |
| Body width at Sg RP (front) | W117 | 1724 (67.9) |
| Vehicle width (front doors open) | W120 | 3901 (153.6) |
| Vehicle width (rear doors open) | W121 | Not Applicable |
| Tumble-home (deg.) | W122 | 27 |
| Outside mirror width | W410 | 1957 (77.0) |

Length

| | | | |
|-------------------------------|------|--------------|---------------------|
| Wheelbase | L101 | 2627 (103.4) | |
| Vehicle length | L103 | 4757 (187.3) | 4751 (187) LW & LZ |
| Overhang (front) | L104 | 1067 (42.0) | |
| Overhang (rear) | L105 | 1063 (41.9) | 1057 (41.6) LW & LZ |
| Upper structure length | L123 | 2693 (106.0) | |
| Rear wheel C/L 'X' coordinate | L127 | 4410 (173.6) | |

Height **

| | | | |
|-------------------------------------|---------|-------------|-------------------|
| Passenger distribution (front/rear) | PD1,2,3 | | ** |
| Trunk/cargo load | | | ** |
| Vehicle height | H101 | 1346 (53.0) | |
| Cowl point to ground | H114 | 925 (36.4) | |
| Deck point to ground | H138 | 998 (39.3) | |
| Rocker panel-front to ground | H112 | 217 (8.5) | 209 (8.2) LW & LZ |
| Rocker panel-rear to ground | H111 | 222 (8.7) | 214 (8.4) LW & LZ |
| Windshield slope angle (deg.) | H122 | 60.5 | |
| Backlight slope angle (deg.) | H121 | 65 | |

Ground Clearance **

| | | | |
|---|------|------------------|--|
| Front bumper to ground | H102 | 259 (10.2) | |
| Rear bumper to ground | H104 | 264 (10.4) | |
| Bumper to ground front at curb mass (wt.) | H103 | 276 (10.9) | |
| Bumper to ground rear at curb mass (wt.) | H105 | 292 (11.5) | |
| Angle of approach (deg.) | H106 | 13 | |
| Angle of departure (deg.) | H107 | 19 | |
| Ramp breakover angle (deg.) | H147 | 15 | |
| Axle differential to ground (front/rear) | H153 | Not Available | |
| Min. running ground clearance | H156 | 143 (5.6) | |
| Location of min. run. grd. clear. | | Front Suspension | |

** All Vehicle Height And Ground Clearance Are Made Using EPA Loaded Vehicle Weight, Loading Conditions.

EPA Loaded Vehicle Weight is the Base Vehicle Weight Plus All Coolant and Fluids Necessary For Operation Plus 100% Of The Fuel Capacity, Plus The Weight Of All Options And Accessories Which Weigh Three Pounds Or More And Which Are Sold On At Least 33% Of The Car Line, Plus Two Occupants.

MVMA Specifications

Vehicle Line BERETTA
 Model Year 1993 Issued 9-92 Revised _____

METRIC (U.S. Customary) Vehicle Dimensions

See Key Sheets for Definitions

Model Code/Description

BASE

Front Compartment

SAE Ref. No.

| | | |
|--|-----|--------------|
| SgRP front, 'X' coordinate | L31 | 3138 (123.5) |
| Effective head room | H81 | 856 (37.6) |
| Max. eff. leg room (accelerator) | L34 | 1102 (43.4) |
| SgRP to heel point | H30 | 241 (9.5) |
| SgRP to heel point | L53 | 908 (35.7) |
| Back angle (deg.) | L40 | 26.5 |
| Hip angle (deg.) | L42 | 103 |
| Knee angle (deg.) | L44 | 136.5 |
| Foot angle (deg.) | L46 | 88.5 |
| Design H-point front travel | L17 | 212 (8.3) |
| Normal driving & riding seat track trvl. | L23 | 189 (7.4) |
| Shoulder room | W3 | 1392 (54.8) |
| Hip room | W5 | 1299 (51.1) |
| *** Upper body opening to ground | H50 | 1222 (48.1) |
| Steering wheel maximum diameter* | W9 | 386 (15.2) |
| Steering wheel angle (deg.) | H18 | 19 |
| Accel. heel pt. to steer. whl. cntr | L11 | -- |
| Accel. heel pt. to steer. whl. cntr | H17 | -- |
| Undepressed floor covering thickness | H87 | 12 (0.5) |

Front Compartment Int. Dim. Are Measured With The Seating Ref. Pt.

(SgRP) mm Forward And mm Upward of Rearmost Position.

Rear Compartment

| | | |
|------------------------------------|-----|-------------|
| SgRP point couple distance | L50 | 760 (29.9) |
| Effective head room | H63 | 930 (36.6) |
| Min. effective leg room | L51 | 827 (32.6) |
| SgRP (second to heel) | H31 | 262 (10.3) |
| Knee clearance | L48 | -39 (-1.5) |
| Shoulder room | W4 | 1402 (55.2) |
| Hip room | W6 | 1290 (50.8) |
| *** Upper body opening to ground | H51 | -- |
| Back angle (deg.) | L41 | 24.5 |
| Hip angle (deg.) | L43 | 81 |
| Knee angle (deg.) | L45 | 87 |
| Foot angle (deg.) | L47 | 119 |
| Depressed floor covering thickness | H73 | 12 (0.5) |

Luggage Compartment

| | | |
|---------------------------------------|------|-------------------------------|
| Usable luggage capacity [L (cu. ft.)] | V1 | 382.6 (13.5) |
| *** Lifter height | H195 | 831 (32.7) 821 (32.3) LW & LZ |

Interior Volumes (EPA Classification)

| | | |
|-----------------------------------|--|---------|
| Vehicle class | | Compact |
| Interior volume index (cu. ft.)** | | 103.4 |
| Trunk / cargo index (cu. ft.) | | 13.5 |

* See page 14.

** Includes passenger and trunk / cargo index - see definition page 32.

*** EPA Loaded Vehicle Weight, Loading Conditions.

All Linear Dimensions Are In Millimeters (Inches).

MVMA Specifications

Vehicle Line BERETTA
 Model Year 1993 Issued 9-92 Revised(*)

METRIC (U.S. Customary) Vehicle Dimensions

See Key Sheets for Definitions

Model Code/Description

2-DOOR NOTCHBACK COUPES

Station Wagon / MPV**

- Third Seat

SAE Ref. No. (NOT APPLICABLE)

| | SAE Ref. No. | (NOT APPLICABLE) |
|-----------------------|--------------|------------------|
| Seat facing direction | SD1 | |
| SgRP couple distance | L85 | |
| Shoulder room | W85 | |
| Hip Room | W88 | |
| Effective leg room | L88 | |
| Effective head room | H88 | |
| SgRP to heel point | H87 | |
| Knee clearance | L87 | |
| Back angle (deg.) | L88 | |
| Hip angle (deg.) | L89 | |
| Knee angle (deg.) | L90 | |
| Foot angle (deg.) | L91 | |

Station Wagon / MPV** Cargo Space

(NOT APPLICABLE)

| | SAE Ref. No. | (NOT APPLICABLE) |
|--|--------------|------------------|
| Cargo length (open front) | L200 | |
| Cargo length (open second) | L201 | |
| Cargo length (closed front) | L202 | |
| Cargo length (closed second) | L203 | |
| Cargo length at belt (front) | L204 | |
| Cargo length at belt (second) | L205 | |
| Cargo width (wheelhouse) | W201 | |
| Rear opening width at floor | W203 | |
| Opening width at belt | W204 | |
| Min. rear opening width above belt | W205 | |
| Cargo height | H201 | |
| Rear opening height | H202 | |
| * Tailgate to ground height | H250 | |
| Front seat back to load floor height | H197 | |
| Cargo volume index cu. m. (cu.ft.) | V2 | |
| Hidden cargo vol. index cu. m.(cu.ft.) | V4 | |
| Cargo volume index--rear of 2-seat | V10 | |
| Cargo volume index** | V8 | |
| Cargo width at floor** | W500 | |
| Maximum cargo height** | H505 | |

Hatchback - Cargo Space

(NOT APPLICABLE)

| | SAE Ref. No. | (NOT APPLICABLE) |
|--|--------------|------------------|
| Cargo length at front seatback height | L208 | |
| Cargo length at floor (front) | L209 | |
| Cargo length at second seatback height | L210 | |
| Cargo length at floor (second) | L211 | |
| Front seatback to load floor height | H197 | |
| Second seatback to load floor height | H198 | |
| Cargo volume index cu. m. (cu. ft.) | V3 | |
| Hidden cargo vol. index cu. m.(cu.ft.) | V4 | |
| Cargo volume index--rear of 2-seat | V11 | |

* EPA Loaded Vehicle Weight, Loading Conditions

** MPV - Multipurpose Vehicle

All Linear Dimensions Are In Millimeters (Inches)

MVMA Specifications

Vehicle Line BERETTA
 Model Year 1993 Issued 9-92 Revised(*) _____

METRIC (U.S. Customary)

Model Code/
Description

2-DOOR NOTCHBACK COUPES

Vehicle Fiducial Marks

| Fiducial Mark Number* | Define Coordinate Location | |
|--|----------------------------|---|
| Front | X | Fiducial Mark To Vertical Zero Grid Line - Front Measured Horizontally, From The Zero Grid Line To The Front Fiducial Mark Located On Top Of The Front Seat Adjuster Mounting Bolt. |
| | Y | Fiducial Mark To Centerline Of Car - Front, Width Measurement Made From Centerline Car To Fiducial Mark Located On Top Of The Front Seat Adjuster Mounting Bolt. |
| | Z | Fiducial Mark To Horizontal Zero Grid Line - Front, Measured Vertically From The Zero Grid Line Front Fiducial Mark Located On Top Of The Front Seat Adjuster Mounting Bolt. |
| Rear | X | Fiducial Mark To Vertical Zero Grid Line - Rear, Measured Horizontally From The Zero Grid Line To Rear Fiducial Mark Located On The Rail (Compartment Pan - Longitudinal). |
| | Y | Fiducial Mark To Centerline Of Car - Rear, Width Measurement Made From Centerline Of Car To Fiducial Mark Located On The Rail (Compartment Pan - Longitudinal). |
| | Z | Fiducial Mark To Horizontal Zero Grid Line - Rear, Measured Vertically From The Zero Grid Line To Rear Fiducial Mark Located On The Rail (Compartment Pan - Longitudinal). |
| NOTE: Provide 3 of 4 Fiducial Mark Locations | | |
| Front | W21** | 346 (13.6) |
| | L54** | 2761 (108.7) |
| | H81** | 211 (8.3) |
| | *** H181** | 238 (9.4) |
| | *** H163** | 260 (10.2) |
| Rear | W22** | 440 (17.3) |
| | L55** | 4953 (195.0) |
| | H82** | 362 (14.3) |
| | *** H182** | 398 (15.7) |
| | *** H164** | 426 (16.8) |

- * Reference - SAE Recommended Practice, J182, Motor Vehicle Fiducial Marks.
 - ** Reference - SAE Recommended Practice J1100 - Motor Vehicle Dimensions.
 - *** EPA Loaded Vehicle Weight, Loading Conditions
- All Linear Dimensions Are In Millimeters (Inches)

MVMA Specifications

METRIC (U.S. Customary)

Vehicle Line BERETTA
 Model Year 1993 Issued 9-92 Revised(*)

| | | Optional Equipment Differential Mass (weight)* | | | |
|------|--------------------------------------|--|----------------|----------------|---------------------------------------|
| Code | Equipment | MASS, kg. (lb.) | | | Remarks Restrictions, Requirements |
| | | Front | Rear | Total | |
| AU3 | Power Door Lock System | .8 (1.3) | 1.2 (2.6) | 1.8 (3.9) | |
| A31 | Power Windows | 1.4 (3.1) | 2.2 (4.8) | 3.8 (7.9) | |
| A90 | Power Trunk Opener | -2 (-0.4) | 1.0 (2.2) | .8 (1.8) | |
| B19 | Custom Interior | 1.0 (2.2) | 1.0 (2.2) | 2.0 (4.4) | Standard On 'GT' Model (Z21) |
| B34 | Floor Mats - Front | 1.0 (2.2) | .2 (0.4) | 1.2 (2.6) | |
| B35 | Floor Mats - Rear | .2 (0.4) | .6 (1.3) | .8 (1.7) | |
| CD4 | Intermittent Windshield Wiper System | .2 (0.4) | 0 (0) | .2 (0.4) | |
| C49 | Electric Rear Window Defogger | 0 (0) | .4 (0.9) | .4 (0.9) | |
| C60 | Air Conditioning | 21.6 (47.6) | -1.4 (-3.1) | 20.2 (44.5) | With RPO LN2 / LGO ENGINES |
| | | 21.2 (46.7) | -1.4 (-3.1) | 19.8 (43.6) | With RPO LH0 Engine |
| K05 | Engine Block Heater | .2 (0.4) | 0 (0) | .2 (0.4) | |
| K34 | Electronic Speed Control | 1.8 (3.9) | 0 (0) | 1.8 (3.9) | |

* Also see Engine - General Section for dressed engine mass (weight).

MVMA Specifications

METRIC (U.S. Customary)

Vehicle Line BERETTA
 Model Year 1993 Issued 9-92 Revised(*) _____

| | | Optional Equipment Differential Mass (weight)* | | | |
|------|---|--|----------------|-----------------|---|
| Code | Equipment | MASS, kg. (lb.) | | | Remarks Restrictions, Requirements |
| | | Front | Rear | Total | |
| LH0 | 3.1 Liter V6 Engine | 45 (99) | -3.0 (-6.6) | 42 (93) | |
| MD9 | Automatic Transmission | 18.2 (40.1) | -1.6 (-3.5) | 16.6 (36.6) | With RPO LN2 Engine |
| | | 16.6 (36.6) | -1.4 (-3.1) | 15.2 (33.5) | With RPO LH0 Engine |
| N33 | Comfortilt Steering Wheel | .4 (0.9) | .2 (0.4) | .6 (1.3) | |
| PF2 | Styled Aluminum Wheels - 15" | -3.2 (-7.0) | -3.2 (-7.0) | -6.4 (-14.0) | |
| UA1 | Heavy Duty Battery | 3.0 (6.6) | -0.4 (-0.9) | 2.6 (5.7) | Required With Auto. Trans. On L4. Mandatory For Canada |
| UM6 | AM/FM Stereo Radio, Cassette Player With Clock | | | 0 | |
| VK3 | Front License Plate Mounting | 0.4 (0.9) | 0 (0) | 0.4 (0.9) | |
| V56 | Deck Lid Luggage Rack (Charcoal) | .6 (1.3) | 2.6 (5.7) | 3.2 (7.0) | |
| Z21 | 'Beretta GT' Option | 53.8 (118.6) | 9.0 (19.8) | 62.8 (138.4) | |
| | | | | | |
| | | | | | |
| | | | | | |
| | | | | | |
| | | | | | |

* Also see Engine - General Section for dressed engine mass (weight).

MVMA Specifications

METRIC (U.S. Customary)

Exterior Vehicle And Body Dimensions - Key Sheet

Exterior Width

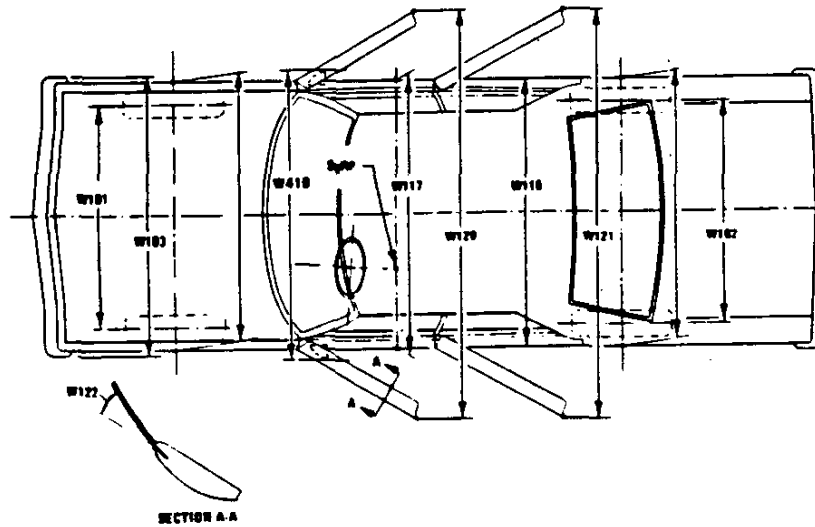

Exterior Length & Height

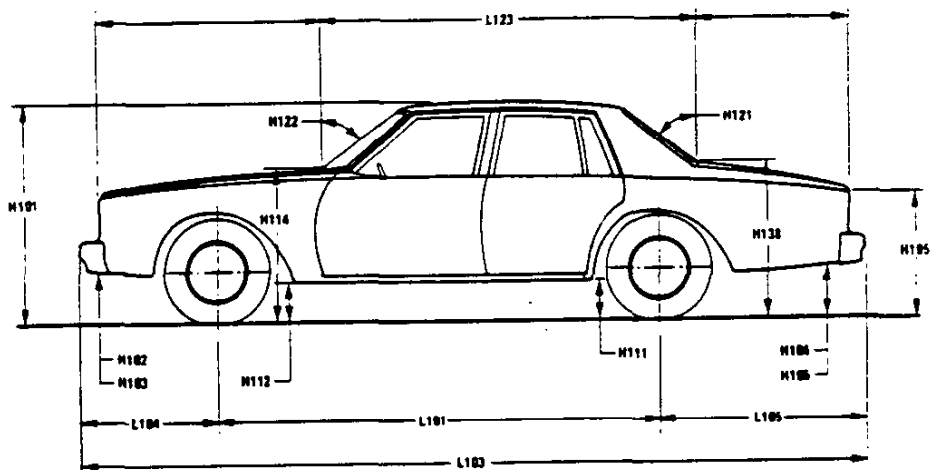

Exterior Ground Clearance

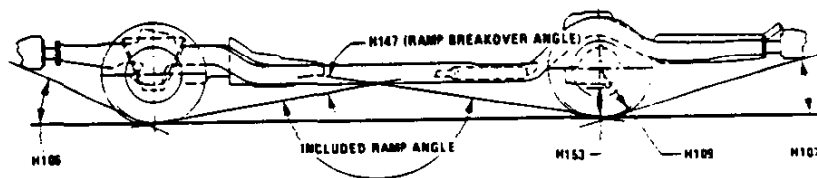

MVMA Specifications Form

METRIC (U.S. Customary)

Interior Vehicle And Body Dimensions – Key Sheet

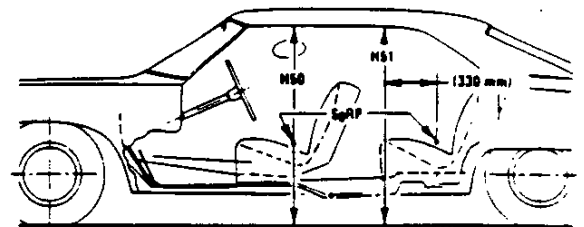
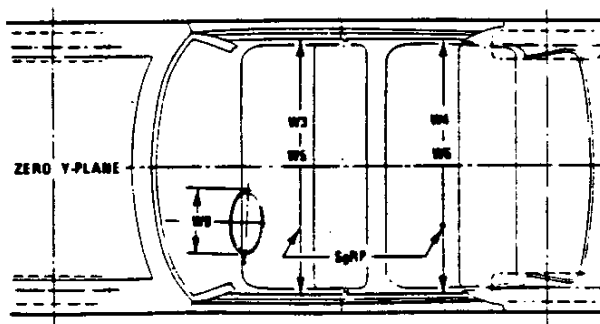
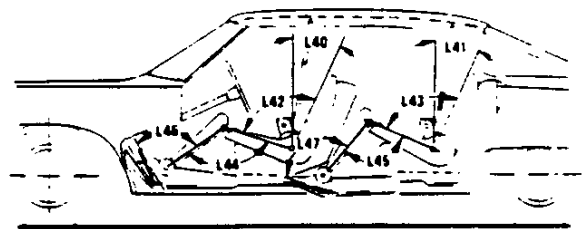
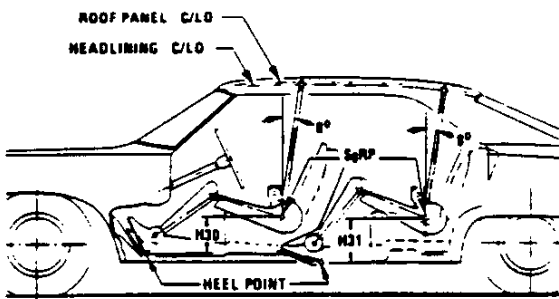
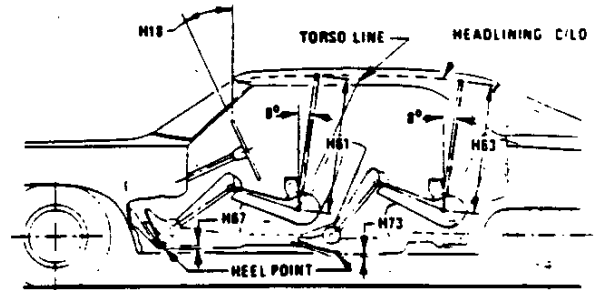
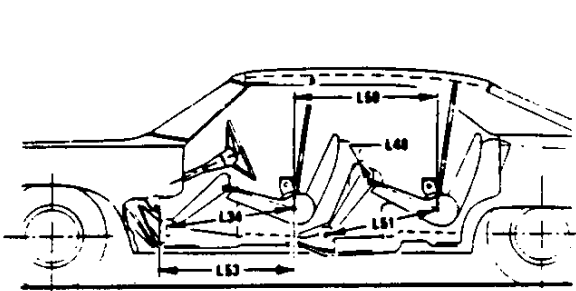

MVMA Specifications

METRIC (U.S. Customary)

Interior Vehicle And Body Dimensions – Key Sheet

Third Seat

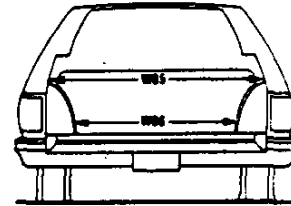
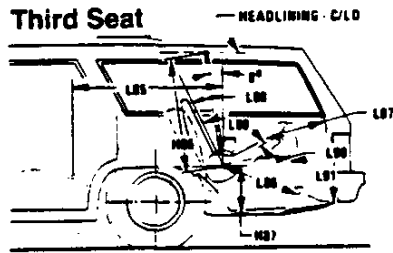

Cargo Space

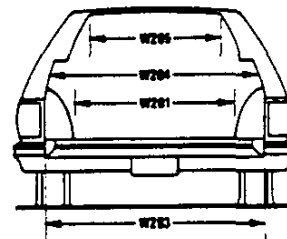
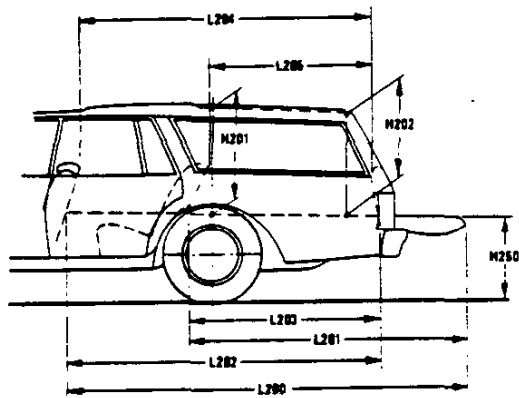

Station Wagon

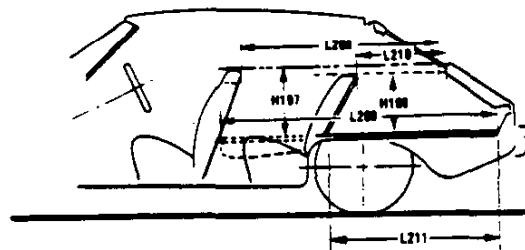

Hatchback

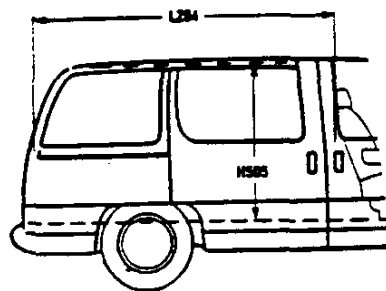

Multipurpose Vehicle

MVMA Specifications

METRIC (U.S. Customary)

Exterior Vehicle And Body Dimensions – Key Sheet Dimensions Definitions

Seating Reference Point

SEATING REFERENCE POINT means the manufacturer's design reference point which –
(a) Establishes the rearmost normal design driving or riding position of each designated seating position in a vehicle;
(b) Has coordinates established relative to the design vehicle structure;
(c) Simulates the position of the pivot center of the human torso and thigh; and
(d) Is the reference point employed to position the two dimensional templates described in SAE Recommended Practice J826, "Devices for Use in Defining and Measuring Vehicle Seating Accommodations."

Width Dimensions

- W101 TREAD – FRONT. The dimension measured between the tire centerlines at the ground.
- W102 TREAD – REAR. The dimension measured between the tire centerlines at the ground. In case of dual wheels, the dimension will be measured to the centerline of tire and wheel assemblies.
- W103 VEHICLE WIDTH. The maximum dimension measured between the widest point on the vehicle, excluding exterior mirrors, flexible mud flaps, marker lamps, but including bumpers, moldings, sheet metal protrusions or dual wheels, if standard equipment.
- W117 BODY WIDTH AT SgRP – FRONT. The dimension measured laterally between the widest points on the body at the SgRP-front, excluding door handles, applied moldings, or appliques.
- W120 VEHICLE WIDTH – FRONT DOORS OPEN. The dimension measured between the widest point on the front doors in maximum hold-open position.
- W121 VEHICLE WIDTH – REAR DOORS OPEN. The dimension measured between the widest point on the rear doors in maximum hold-open position. For vehicles with a rear door on only one side, this dimension is to the zero "Y" plane.
- W122 TUMBLE – HOME. STRAIGHT SIDE GLASS. The angle measured from a vertical to the outside surface of the front door glass at the SgRP "X" plane.
CURVED SIDE GLASS. The angle measured from a vertical to a chord extending from the upper DLO to the lower DLO at the outside surface of the front door glass at the front SgRP "X" plane.
- W410 OUTSIDE MIRROR WIDTH. The dimension between the widest point on the outside mirrors. The standard right and left mirror adjusted for normal driving will be shown unless otherwise noted. When only one outside mirror is standard, the dimension will be to the zero "Y" plane.

Length Dimensions

- L101 WHEELBASE (WB). The dimension measured longitudinally between front and rear wheel centerlines. In case of dual rear axles, the dimension shall be to the midpoint of the centerlines of the rear wheels.
- L103 VEHICLE LENGTH. The maximum dimension measured longitudinally between the foremost point and the rearmost point on the vehicle, including bumper, bumper guards, tow hooks and/or rub strips, if standard equipment.
- L104 OVERHAND – FRONT. The dimension measured longitudinally from the centerline of the front wheels to the foremost point on the vehicle including bumper, bumper guards, tow hooks and/or rub strips, if standard equipment.
- L105 OVERHANG – REAR. The dimension measured longitudinally from the centerline of the rear wheels; or in the case of dual rear axles, the dimension shall be the midpoint of the centerlines of the rear wheels, to the rearmost point on the vehicle including rear bumpers, bumper guards, tow hooks and rub strips, if standard equipment.

- L123 UPPER STRUCTURE LENGTH. The dimension measured longitudinally from the cowl point to the deck point.
- L127 REAR WHEEL CENTERLINE "X" COORDINATE or in the case of dual rear axles, the coordinate shall be the midpoint of the distance between the rear axle centerlines.

Height Dimensions

- H101 VEHICLE HEIGHT. The dimension measured vertically from the highest point on the vehicle body to ground.
- H111 ROCKER PANEL – REAR TO GROUND. The dimension measured vertically from the bottom of the rocker or side quarter panel at the front of the rear wheel opening, excluding flanges, to ground.
- H112 ROCKER PANEL – FRONT TO GROUND. The dimension measured vertically from the foremost point on the bottom of the rocker panels, excluding flanges, to ground.
- H114 COWL POINT TO GROUND. Measured at zero "Y" plane.
- H121 BACKLIGHT SLOPE ANGLE. The angle between the vertical reference line and the surface of backlight at vehicle zero "Y" plane. For curve backlight, the angle is to chord of backlight arc from lower DLO to upper DLO.
- H122 WINDSHIELD SLOPE ANGLE. The angle between the vertical reference line and a chord of the windshield arc running from the lower DLO to the upper DLO at the vehicle zero "Y" plane. In the case of wrap over glass, the angle to be measured will be formed by a chord 457 mm (18.0 in.) long drawn from the lower DLO to the intersecting point on the windshield.
- H138 DECK POINT TO GROUND. Measured at zero "Y" plane.
- H109 STATICLOAD – TIRE RADIUS – REAR. Specified by the manufacturer in accordance with composite TIRE SECTION STANDARD.

Ground Clearance Dimensions

- H102 FRONT BUMPER TO GROUND. The minimum dimension measured vertically from the lowest point on the front bumper to ground, including bumper guards, if standard equipment.
- H103 FRONT BUMPER TO GROUND – CURB MASS (WT.). Measured in the same manner as H102.
- H104 REAR BUMPER TO GROUND. The minimum dimension measured vertically from the lowest point on the rear bumper to ground, including bumper guards, if standard equipment.
- H105 REAR BUMPER TO GROUND – CURB MASS (WT.). Measured in the same manner as H104.
- H106 ANGLE OF APPROACH. The angle measured between a line tangent to the front tire static loaded radius arc and the initial point of structural interference forward of the front tire to ground. The limiting structural component shall be designated.
- H107 ANGLE OF DEPARTURE. The angle measured between a line tangent to the rear tire static loaded radius arc and the initial point of structural interference rearward of the rear tire to ground. The limiting component shall be designated.
- H147 RAMP BREAKOVER ANGLE. The angle measured between two lines tangent to the front and rear tire static loaded radius and intersecting at a point on the underside of the vehicle which defines the largest ramp over which the vehicle can roll.
- H153 REAR AXLE DIFFERENTIAL TO GROUND. The minimum dimension measured from the rear axle differential to ground.
- H156 MINIMUM RUNNING GROUND CLEARANCE. The minimum dimension measured from the sprung vehicle to ground. Specify location.

MVMA S METRIC (L)

Interior Vehicle Dimensions

Glass Areas

- S1 Windshield
- S2 Side window and rear window
- S3 Backlight
- S4 Total area

Fiducial Mark D:

- L54 "X" coord
- W21 "Y" coord
- H81 "Z" coord
- H161 Height "Z"
- H163 Height "Z"
- L55 "X" coord
- W22 "Y" coord
- W82 "Z" coord
- H162 Height "Z"
- H164 Height "Z"

Front Compartm

- L11 ACCELERATOR CENTER POINT TO AHP TO TORO and a plane wheel rim
- L17 DESIGNATED HORIZONTAL FOREMOST J1100
- L23 NORMAL The dimension the design point on the travel use positions
- L31 SgRP - FRONT
- L34 MAXIMUM dimension to the SgRP foot on the with SgRP pedal mark If the accelerator foot flat on
- L40 BACK ANGLE vertical line seatback position
- L42 HIP ANGLE line and torso centerline
- L44 KNEE ANGLE centerline leg
- L46 FOOT ANGLE lower leg of the bare SAE J826
- L53 SgRP - FRONT tally from
- W3 SHOULDER OPENING measured laterally plane through and 254 mm door assist

et

parts

measured
the
SAE

HEEL
on
spec
heel
back
flooring

The
center
right
torso
torso
torso

torso
torso

torso
torso

heel
heel
Ref

heel
heel
Ref

heel
heel
Ref

- W5 HIP ROOM - FRONT. The minimum dimension measured laterally between the trimmed surfaces on the "X" plane through the SgRP - front within 25 mm (1.0 in.) below and 76 mm (3.0 in.) above the SgRP - front and 76 mm (3.0 in.) fore and aft of the SgRP - front.
- W9 STEERING WHEEL MAXIMUM OUTSIDE DIAMETER. Define if other than round.
- H7 ACCELERATOR HEEL POINT TO THE STEERING WHEEL CENTER. The dimension measured vertically from the AHP - front to the intersection of the steering column centerline to a plane tangent to the upper surface of the steering wheel rim.
- H18 STEERING WHEEL ANGLE. The angle measured from a vertical to the surface plane of the steering wheel.
- H30 SgRP - FRONT TO HEEL. The dimension measured vertically from the SgRP - front to the accelerator heel point.
- H50 UPPER BODY OPENING TO GROUND - FRONT. The dimension measured vertically from the trimmed body opening to the ground on the SgRP - front "X" plane.
- H61 EFFECTIVE HEAD ROOM - FRONT. The dimension measured along a line 8 deg. rear of vertical from the SgRP - front to the headlining plus 102 mm (4.0 in.).
- H67 FLOOR COVERING THICKNESS - UNDEPRESSED - FRONT. The dimension measured vertically from the surface of the depressed floor covering to the underbody sheet metal at the accelerator heel point.

Rear Compartment Dimensions

- L41 BACK ANGLE - SECOND. The angle measured between a vertical line through the SgRP - second and the torso line
- L43 HIP ANGLE - SECOND. The angle measured between torso line and thigh centerline.
- L45 KNEE ANGLE - SECOND. The angle measured between thigh centerline and lower leg centerline.
- L47 FOOT ANGLE - SECOND. The angle measured between the lower leg centerline and a line tangent to the ball and heel of the three-dimensional device bare foot flesh line (Reference J826).
- L48 KNEE CLEARANCE - SECOND. The minimum dimension measured from the knee pivot center to the back of the front seatback minus 51 mm (2.0 in.).
- L50 SgRP COUPLE DISTANCE - SECOND. The dimension measured horizontally from the driver SgRP - front to the SgRP - second.
- L51 MINIMUM EFFECTIVE LEG ROOM - SECOND. The dimension measured along a line from the ankle pivot center to the SgRP - second plus 254 mm (10.0 in.).
- W4 SHOULDER ROOM - SECOND. The minimum dimension measured laterally between door or quarter trimmed surfaces on the "X" plane through the SgRP - second at height between 254-406 mm (10.0-16.0 in.) above the SgRP - second, excluding the door assist straps and attaching parts.
- W6 HIP ROOM - SECOND. Measured in the same manner as W5.
- H31 SgRP - SECOND TO HEEL. The dimension measured vertically from the SgRP - second to the two dimensional device heel point on the depressed floor covering.
- H51 UPPER BODY OPENING TO GROUND - SECOND. The dimension measured vertically from the trimmed body opening to the ground on the "X" plane 330 mm (13.0 in.) forward of the SgRP - second.
- H63 EFFECTIVE HEAD ROOM - SECOND. The dimension measured along a line 8 deg. rear of vertical from the SgRP to the headlining, plus 102 mm (4.0 in.).
- H73 FLOOR COVERING - DEPRESSED - SECOND. The dimension measured vertically from the heel point to the underbody sheet metal

MVMA Specifications

METRIC (U.S. Customary)

Interior Vehicle And Body Dimensions – Key Sheet Dimensions Definitions

Luggage Compartment Dimensions

V1 USABLE LUGGAGE CAPACITY – Total of volumes of individual pieces of standard luggage set plus H-boxes stowed in the luggage compartment in accordance with the procedure described in paragraph 8.2 of SAE-J1100a.

Interior Volumes (EPA Classification)

The Interior Volume Index is listed for each body style except two seaters. The Interior Volume Index estimates the space in a car. It is based on four measurements – head room, shoulder room, hip room, and leg room – for the front and rear seats, plus trunk capacity.

The Trunk/Cargo Index is an estimate of the size of the trunk/cargo space. In station wagons and hatchbacks it is an estimate of the space behind the second seat.

Station Wagon / MPV – Third Seat Dimensions

L85 SgRP COUPLE DISTANCE – THIRD. The dimension measured horizontally from the SgRP – second to the SgRP – third.

L86 EFFECTIVE LEG ROOM – THIRD. The dimension measured along a line from the ankle pivot center to the SgRP – third plus 254 mm (10.0 in.).

L87 KNEE CLEARANCE – THIRD. The minimum dimension from the knee pivot center to the back of second seatback minus a constant of 51 mm (2.0 in.). With rear-facing third seat, dimension is measured to closure.

L88 BACK ANGLE – THIRD. Measured in the same manner as L41.

L89 HIP ANGLE – THIRD. Measured in the same manner as L43.

L90 KNEE ANGLE – THIRD. Measured in the same manner as L45.

L91 FOOT ANGLE – THIRD. Measured in the same manner as L47.

W85 SHOULDER ROOM – THIRD. Measured in the same manner as W4.

W86 HIP ROOM – THIRD. Measured in the same manner as W5.

H86 EFFECTIVE HEAD ROOM – THIRD. The dimension, measured along a line 8 deg. from the SgRP – third to the headlining rear of vertical plus a constant of 102 mm (4.0 in.).

H87 SgRP – THIRD TO HEEL POINT

SD1 SEAT FACING DIRECTION – THIRD

Station Wagon / MPV – Cargo Space Dimensions

L200 CARGO LENGTH – OPEN – FRONT. The minimum dimension measured longitudinally from the back of the front seatback at the height of the undepressed floor covering to the rearmost point on the undepressed floor covering on the open tailgate or cargo surface if the rear closure is a conventional door type tailgate at the zero "Y" plane.

L201 CARGO LENGTH – OPEN – SECOND. The dimension measured longitudinally from the back of the second seatback at the height of the undepressed floor covering to the rearmost point on the undepressed floor covering on the open tailgate or cargo floor surface if the rear closure is a conventional door type tailgate, at the zero "Y" plane.

L202 CARGO LENGTH – CLOSED – FRONT. The minimum dimension measured horizontally from the back of the front seat at the height of the undepressed floor covering to the rearmost point on the undepressed floor covering on the closed tailgate or taildoor for station wagons, trucks and mpv's at the zero "Y" plane.

L203 CARGO LENGTH – CLOSED – SECOND. The dimension measured horizontally from the back of the second seat at the height of the undepressed floor covering to the rearmost point on the undepressed floor covering on the closed tailgate or taildoor for station wagons, trucks and mpv's at the zero "Y" plane.

L204 CARGO LENGTH AT BELT – FRONT. The minimum dimension measured horizontally from the back of the front seatback at the seatback top to the foremost normal surface of the closed tailgate or inside surface of the cab backpanel at the height of the belt, on the zero "Y" plane.

L205 CARGO LENGTH AT BELT – SECOND. The minimum dimension measured horizontally from the back of the second seatback at the seatback top to the foremost normal surface of the closed tailgate at the height of the belt, on the zero "Y" plane.

W201 CARGO WIDTH – WHEELHOUSE. The minimum dimension measured laterally between the trimmed wheelhousings at floor level. For any vehicle not trimmed, measure to the sheet metal.

W203 REAR OPENING WIDTH AT FLOOR. The minimum dimension measured laterally between the limiting interferences of the rear opening at floor level.

W204 REAR OPENING WIDTH AT BELT. The minimum dimension measured laterally between the limiting interferences of the rear opening at belt height or top of pick box.

W205 REAR OPENING WIDTH ABOVE BELT. The minimum dimension measured laterally between the limiting interferences of the rear opening above the belt height.

W500 CARGO WIDTH AT FLOOR. The maximum dimension measured laterally between the limiting interferences at the floor level. This dimension shall include ribs and pillars, but will exclude wheelhouses.

H197 FRONT SEATBACK TO LOAD FLOOR HEIGHT. The dimension measured vertically from the horizontal tangent to the top of the seatback to the undepressed floor covering.

H201 CARGO HEIGHT. The dimension measured vertically from the top of the undepressed floor covering to the headlining at the rear wheel "X" coordinate on the zero "Y" plane.

H202 REAR OPENING HEIGHT. The dimension measured vertically from the top of the undepressed floor covering to the upper trimmed opening on the zero "Y" plane with rear door fully open.

H250 TAILGATE TO GROUND CURB MASS (WT.). The dimension measured vertically from the top of the undepressed floor covering on the lowered tailgate to ground on the zero "Y" plane.

H505 MAXIMUM CARGO HEIGHT. The maximum vertical dimension rear of the front seat from the cargo floor to roof bow or headlining at the zero "Y" plane.

MVMA Specifications

METRIC (U.S. Customary)

Interior Vehicle And Body Dimensions – Key Sheet Dimensions Definitions

V2 STATION WAGON

Measured in inches:

$$\frac{W4 \times H201 \times L204}{1728} = \text{ft}^3$$

Measured in mm:

$$\frac{W4 \times H201 \times L204}{10^9} = \text{m}^3 \text{ (cubic meter)}$$

V4 HIDDEN LUGGAGE CAPACITY – REAR OF FRONT SEAT.

The total volumes of individual pieces of one set of standard luggage stowed in any hidden cargo area below the load floor rear of the front seat.

V5 TRUCKS AND MPV'S WITH OPEN AREA.

Measured in inches:

$$\frac{L506 \times W505 \times H503}{1728} = \text{ft}^3$$

Measured in mm:

$$\frac{L506 \times W505 \times H503}{10^9} = \text{m}^3 \text{ (cubic meter)}$$

V6 TRUCKS AND MPV'S WITH CLOSED AREA

Measured in inches:

$$\frac{L204 \times W500 \times H505}{1728} = \text{ft}^3$$

Measured in mm:

$$\frac{L204 \times W500 \times H505}{10^9} = \text{m}^3 \text{ (cubic meter)}$$

V8 HIDDEN LUGGAGE CAPACITY – REAR OF SECOND SEAT.

The total volume of individual pieces of one set of standard luggage stowed in any hidden cargo area below the load floor rear of the second seat.

V10 STATION WAGON CARGO VOLUME INDEX.

Measured in inches:

$$\frac{H201 \times L205 \times \frac{W4 + W201}{2}}{1728} = \text{ft}^3$$

Measured in mm:

$$\frac{H201 \times L205 \times \frac{W4 + W201}{2}}{10^9} = \text{m}^3 \text{ (cubic meter)}$$

Hatchback – Cargo Space Dimensions

All hatchback cargo dimensions are to be taken with the front seat in full down and rear position, and the rear seat folded down. The hatchback door is in the closed position. (For electronically adjusted seats, see the manufacturer's specifications for Design "H" Point).

L208 CARGO LENGTH AT FRONT SEATBACK HEIGHT. The minimum horizontal dimension from the "X" plane tangent to the rearmost surface of the driver's seatback to the inside limiting interference of the hatchback door on the vehicle zero "Y" plane.

L209 CARGO LENGTH AT FLOOR – FRONT. The minimum horizontal dimension measured at floor level from the rear of the front seatback to the normal limiting interference of the hatchback door on the vehicle zero "Y" plane.

L210 CARGO LENGTH AT SECOND SEATBACK HEIGHT. The minimum dimension measured from the "X" plane tangent to the rearmost surface of second seatback or the load floor which is stowed at least one half of the H198 dimension height above the rear load floor, to the rearmost inside limiting interference on the zero "X" plane.

L211 CARGO LENGTH AT FLOOR – SECOND SEATBACK. The minimum horizontal dimension measured at floor level from the rear of the second seatback or load floor panel to the normal limiting interference of the hatchback door on the vehicle zero "Y" plane.

H197 FRONT SEATBACK TO LOAD HEIGHT. The dimension measured vertically from the horizontal tangent to the top of the seatback to the undepressed floor covering.

H198 SECOND SEATBACK TO LOAD FLOOR HEIGHT. The dimension measured vertically from the second seatback to the undepressed floor covering.

V3 HATCHBACK.

Measured in inches:

$$\frac{L208 - L209}{2} \times W4 \times H197 = \text{ft}^3$$

Measured in mm:

$$\frac{L208 - L209}{2} \times W4 \times H197 = \text{m}^3 \text{ (cubic meter)}$$

V4 HIDDEN LUGGAGE CAPACITY – REAR OF FRONT SEAT. The total volumes of individual pieces of one set of standard luggage stowed in any hidden cargo area below the load floor rear of the front seat.

V11 HATCHBACK CARGO VOLUME INDEX. Usable luggage (one (1) stand and luggage set) below floor:

Measured in inches:

$$\frac{L210 + L211}{2} \times W4 \times H198 = \text{ft}^3$$

Measured in mm:

$$\frac{L210 + L211}{2} \times W4 \times H198 = \text{m}^3 \text{ (cubic meter)}$$

MVMA Specifications

METRIC (U.S. Customary)

Index

| Subject | Page No. | Subject | Page No. |
|---|--------------------|--------------------------------------|----------|
| Alternator | 16 | Passenger Capacity | 1 |
| Axle Drive, Front, Rear, All Four | 2, 9, 10 | Passenger Mass Distribution | 26 |
| Axle Shafts | 10 | Pistons | 3 |
| Battery | 16 | Power Brakes | 12 |
| Body and Miscellaneous Information | 17 | Power, Engine | 2 |
| Brakes - Parking Service | 12, 13 | Power Steering | 14 |
| Camber | 15 | Power Teams | 2 |
| Camshaft | 3 | Propeller Shaft | 10 |
| Capacities | | Pumps - Fuel | 6 |
| Cooling System | 5 | Water | 5 |
| Fuel Tank | 6 | Radiator - Cap, Hoses, Core | 5 |
| Lubricants | | Ratios - Axle, Transaxle | 2, 9, 10 |
| Engine Crankcase | 4 | Compression | 2 |
| Transmission Transaxle | 8, 9 | Steering | 14 |
| Rear Axle | 10 | Transmission Transaxle | 2, 8, 9 |
| Carburetor | 2, 6 | Rear Axle | 2, 10 |
| Caster | 15 | Regulator - Alternator | 16 |
| Climate Control System | 19 | Restraint System | 18 |
| Clutch - Pedal Operated | 8 | Rims | 13 |
| Coil, Ignition | 16 | Rods - Connecting | 4 |
| Connecting Rods | 4 | Scrub Radius | 14 |
| Convenience Equipment | 20-21 | Seats | 17 |
| Cooling System | 5 | Shock Absorbers, Front & Rear | 11 |
| Crankshaft | 4 | Spark Plugs | 16 |
| Cylinders and Cylinder Head | 3 | Speedometer | 15 |
| Diesel Information | 4 | Springs - Front & Rear Suspension | 11 |
| Dimension Definitions | | Stabilizer (Sway Bar) - Front & Rear | 11 |
| Key Sheet - Exterior | 28, 31, 32 | Starting System | 16 |
| Key Sheet - Interior | 29, 30, 32, 33, 34 | Steering | 14 |
| Electrical System | 15, 16 | Suppression - Ignition, Radio | 16 |
| Emission Controls | 7 | Suspension - Front & Rear | 11 |
| Engine - General | | Tail Pipe | 7 |
| Bore, Stroke, Type | 3 | Theft Protection | 21 |
| Compression Ratio | 2 | Thermostat, Cooling | 5 |
| Displacement | 2, 3 | Tires | 13 |
| Firing Order, Cylinder Numbering | 3 | Toe-In | 15 |
| General Information, Power & Torque | 2 | Torque Converter | 9 |
| Intake System | 4 | Torque - Engine | 2, 8, 9 |
| Power Teams | 2 | Trailer Towing | 21 |
| Exhaust System | 7 | Transaxle | 9 |
| Equipment Availability, Convenience | 20 | Transmission - Types | 2, 8, 9 |
| Fan, Cooling | 5 | Transmission - Automatic | 2, 9 |
| Filters - Engine Oil, Fuel System | 4 | Transmission - Manual | 2, 8 |
| Four Wheel Drive | 10 | Transmission - Ratios | 2, 8, 9 |
| Frame | 17 | Tread | 22 |
| Front Suspension | 11 | Trunk Cargo Load | 1 |
| Front Wheel Drive Unit | 10 | Trunk Luggage Capacity | 23 |
| Fuel Economy, EPA | 1 | Turning Diameter | 14 |
| Fuel Injection | 6 | Unrozed Construction | 18 |
| Fuel System | 6 | Universal Joints, Propeller Shaft | 10 |
| Fuel Tank | 6 | Valve System | 4 |
| Glass | 18 | Vehicle Dimensions | |
| Headlamps | 18 | Width | 22 |
| Headroom - Body | 23, 24 | Length | 22 |
| Heights | 22 | Height | 22 |
| Horns | 15 | Ground Clearance | 22 |
| Horsepower - Brake | 2 | Front Compartment | 23 |
| Ignition System | 16 | Rear Compartment | 23 |
| Inflation - Tires | 13 | Luggage Compartment | 23 |
| Interior Volumes | 23 | Station Wagon - Third Seat | 24 |
| Instruments | 15 | Station Wagon - Cargo Space | 24 |
| Legroom | 23, 24 | Hatchback - Cargo Space | 24 |
| Lengths | 22 | Fiducial Marks | 25 |
| Leveling, Suspension | 11 | Voltage Regulator | 16 |
| Lifters, Valve | 4 | Water Pump | 5 |
| Linings - Clutch, Brake | 8, 12 | Weights | 26, 27 |
| Lubrication - Engine, Transmission, Transaxle | 4, 8, 9 | Wheel Alignment | 15 |
| Luggage Compartment | 23 | Wheelbase | 22 |
| Models | 1 | Wheels & Tires | 13 |
| Motor Starting | 16 | Wheel Spindle | 14 |
| Muffler | 7 | Widths | 22 |
| Origin | 1 | Windshield | 18 |
| | | Windshield Wiper and Washer | 15 |