



MANUFACTURERS MOTOR VEHICLE SPECIFICATIONS

METRIC(U.S. Customary)

Passenger Car

1987

Manufacturer	Chevrolet Motor Division General Motors Corporation	Car Line	Chevette	
Mailing Address	Chevrolet-Pontiac-Canada Group Engineering Center General Motors Corporation 30003 Van Dyke Warren, MI 48090-9060	Issued	June, 1986	Revised September, 1986

Questions concerning these specifications should be directed to the manufacturer whose address is shown above.

The information contained herein is prepared, distributed by, and is solely the responsibility of the automobile manufacturing company to whose products it relates. This specification form was developed by the automobile manufacturing companies under the auspices of the Motor Vehicle Manufacturers Association of the United States, Inc.

The General Specifications herein are those in effect at date of compilation and are subject to change without notice by the manufacturer.

Blank Forms Provided by Technical Affairs Division



Motor Vehicle Manufacturers Association
of the United States, Inc.

MVMA Specifications Form Passenger Car

METRIC (U.S. Customary)

Table of Contents

1	Car Models
2	Power Teams
3-6	Engine
4	Lubrication System
4	Diesel Information
5	Cooling System
6	Fuel System
7	Vehicle Emission Control
7	Exhaust System
8-10	Transmission, Axles and Shafts
11	Suspension-Front and Rear
12-13	Brakes
13	Tires and Wheels
14-15	Steering
15-16	Electrical
17	Body – Miscellaneous Information
18	Restraint System
18	Frame
18	Glass
19	Convenience Equipment
20-22	Car and Body Dimensions
23	Vehicle Fiducial Marks
24	Lamps and Headlamps
25	Vehicle Mass (Weight)
26	Optional Equipment Differential Mass (Weight)
27-33	Car and Body Dimensions Definitions - Key Sheets
34	Index

NOTE:

1. This form uses both SI metric units and U.S. Customary units. The metric unit of measure is presented first, and the U.S. Customary unit follows in parentheses.
2. UNLESS OTHERWISE INDICATED:
 - a. Specifications apply to standard models without optional equipment. Significant deviations are noted.
 - b. Nominal design dimensions are used throughout these specifications.
 - c. All linear dimensions are in millimeters (inches), and all mass (weight) specifications are in kilograms (pounds).
3. The General Specifications herein are those in effect at date of completion and are subject to change without notice by the manufacturer.
4. Additional Car and Body Dimensions (based in part on SAE J1100 "Motor Vehicle Dimensions") may be available from the manufacturer.

**MVMA Specifications Form
Passenger Car**

Car Line CHEVETTE
 Model Year 1987 Issued 6-86 Revised (#) _____

METRIC (U.S. Customary)

Car Models

Model Description & Drive (FWD/RWD)	Introduction Date	Make, Car Line, Series, Body Type (Mfr's Model Code)	No. of Designated Seating Positions (Front/Rear)		Max. Trunk Cargo Load-Kilograms (Pounds)
Rear Wheel Drive					
<u>Chevette "CS"</u>					
2-Door Hatchback Coupe		1TB08	2	2	45.4 (100.1)
4-Door Hatchback Sedan		1TB68	2	2	45.4 (100.1)

Note: Any specifications on the following pages specific to California requirements are indicated accordingly.

MVMA Specifications Form Passenger Car

Car Line CHEVETTE
 Model Year 1987 Issued 6-86 Revised (•) 9-86

METRIC (U.S. Customary)

Power Teams (Indicate whether standard or optional)
 SAE J1349 Net bhp (brake horsepower) and net torque corrected to 77°F/25° C and 29.61 in. Hg/100 kPa atmospheric pressure.

SERIES AVAILABILITY	ENGINE					E x h a u s t S/D	TRANSMISSION/ TRANSAXLE	DRIVE RATIOS (:1) AXLE RATIO			
	Displ. Liters (in ³)	Carb. (Barrels, Fl, etc.)	Compr. Ratio	SAE Net at RPM				Overall Base Veh. Drive	Overall Opt. Veh. Drive		
				Power kW (bhp)	Torque N·m (lb. ft.)						
Base - 49 States All	L-4 1.6Liter (98 CID) L17	2	9.0:1	(65 @ 5600)	(80 @ 3200)	S	Man 4- Speed Base (3.75:1 (MY1) low)\$	3.36+	3.36	3.62@*	3.62
							Man 5-Speed Avail (3.76:1) (MB4) low)\$	3.36+	2.89	3.62@*	3.11
							Auto '180c' - Avail (MD2)	3.36	3.36	3.62*	3.62
Calif only All	L-4 1.6Liter (98 CID) L17	2	9.0:1	(65 @ 5600)	(80 @ 3200)	S	Man 4-Speed Base (3.75:1 (MY1) low)\$	3.62	3.62	--	--
							Man 5-Speed Avail (3.76:1) (MB4) low)\$	3.62	3.11	--	--
							Auto '180c' - Avail (MD2)	3.36	3.36	3.62*	3.62
+ - Without A/C \$ - Power steering not available. @ - Base with A/C, optional without A/C * - Optional ratio											

MVMA Specifications Form Passenger Car

Car Line CHEVETTE
 Model Year 1987 Issued 6-86 Revised (e) 9-86

METRIC (U.S. Customary)

Engine Description/Carb.
 Engine Code

1.6 Liter L-4 (98 CID)
 2-Bbl. Carburetor
 RPO L17

ENGINE - GENERAL

Type & description (inline, V, angle, flat, location, front, mid, rear, transverse, longitudinal, sohc, dohc, ohv, hemi, wedge, pre-camber, etc.)	OHC, In line Front Longitudinal
Manufacturer	Chevrolet
No. of cylinders	4
Bore	82 (3.23)
Stroke	75.7 (2.98)
Bore spacing (C/L to C/L)	93.0 (3.66)
Cylinder block material & mass kg (lbs.) (machined)	Cast alloy iron 32.432 (71.5)
Cylinder block deck height	198 (7.8)
Cylinder block length	Not Available
Deck clearance (minimum) (above or below block)	Zero
Cylinder head material & mass kg (lbs.)	Cast alloy iron, swirl port 20.911 (46.1)
Cylinder head volume (cm ³)	Not Applicable
Cylinder liner material	Not Available
Head gasket thickness (compressed)	.95 (.037)
Minimum combustion chamber total volume (cm ³)	Not Available
Cyl. no. system (front to rear)*	L. Bank
	R. Bank
Firing order	1-2-3-4
Intake manifold material & mass [kg (lbs.)]**	1-3-4-2
Exhaust manifold material & mass [kg (lbs.)]**	Cast aluminum 2.118 (4.7)
Recommended fuel (leaded, unleaded, diesel)	Cast iron 4.018 (8.9)
Fuel antiknock index (R + M) 2	Unleaded
Fuel antiknock index (R + M) 2	87
Total dressed engine mass (wt) dry***	144.5 (318.6) auto, 154.6 (340.8) Man.

Engine - Pistons

Material & mass, g (weight, oz.) - piston only	Cast aluminum alloy .400 (14.11)
--	-------------------------------------

Engine - Camshaft

Location	In cylinder head
Material & mass kg (weight, lbs.)	Cast alloy iron 3.166 (6.98)
Drive type	Chain / belt
	Width / pitch
	Belt 19 (0.748)/9.5 (0.374)

* Rear of engine - drive takeoff. View from drive takeoff end to determine left & right side of engine.

** Finished state.

*** Dressed engine mass (weight) includes the following:

All those items necessary to make the engine a complete ready-to-run unit.

MVMA Specifications Form Passenger Car

Car Line CHEVETTE
 Model Year 1987 Issued 6-86 Revised (e) 9-86

METRIC (U.S. Customary)

Engine Description/Carb.
 Engine Code

1.6 Liter L4 (98 CID)
 2-Bbl. Carburetor
 RPO L17

Engine - Valve System

Hydraulic lifters (std., opt., NA)	Hydraulic valve lash adjusters
Valves	4/4
Number intake / exhaust	3900(1.54)/3200(1.26)
Head O.D. intake / exhaust	

Engine - Connecting Rods

Material & mass (kg., (weight, lbs.))*	Forged steel 1141/.354(0.78)@
--	-------------------------------

Engine - Crankshaft

Material & mass (kg., (weight, lbs.))*	Nodular cast iron/12.474(27.50)
End thrust taken by bearing (no.)	5
Number of main bearings	5
Seal (material, one, two piece design, etc.)	Front Rear

Engine - Lubrication System

Normal oil pressure [kPa (psi) at engine rpm]	345-450 (50-65) @ 1200
Type oil intake (floating, stationary)	Stationary
Oil filter system (full flow, part, other)	Full flow
Capacity of c/case, less filter-refill-L (qt.)	3.8 (4.0)

Engine - Diesel Information

Diesel engine manufacturer	
Glow plug, current drain at 0°F	
Injector nozzle	Type Opening pressure [kPa (psi)]
	Not Applicable
Pre-chamber design	
Fuel injection pump	Manufacturer Type
Fuel injection pump drive (belt, chain, gear)	
Supplementary vacuum source (type)	
Fuel heater (yes/no)	
Water separator, description (std., opt.)	
Turbo manufacturer	
Oil cooler-type (oil to engine coolant; oil to ambient air)	
Oil filter	

Engine - Intake System

Turbo charger - manufacturer	Not Applicable
Super charger - manufacturer	"
Charge cooler	"

*Finished State

@ Includes rod, cap, bolts and nuts.

MVMA Specifications Form Passenger Car

Car Line CHEVETTE
 Model Year 1987 Issued 6-86 Revised (●) _____

METRIC (U.S. Customary)

Engine Description/Carb.
 Engine Code

1.6 Liter L-4 (98 CID)
 2-Bbl. Carburetor
 RPO L17

Engine - Cooling System

Coolant recovery system (std., opt., n.a.)	Standard			
Coolant fill location (rad., bottle)	Bottle, coolant recovery			
Radiator cap relief valve pressure [kPa (psi)]	103.4 (15.0)			
Circulation thermostat	Type (choke, bypass)	Choke		
	Starts to open at °C (°F)	88 (190)		
Water pump	Type (centrifugal, other)	Centrifugal, forged aluminum body		
	GPM 1000 pump rpm	6.3 @ 1000 Pump RPM		
	Number of pumps	One		
	Drive (V-belt, other)	V-belt		
	Bearing type	Ball/Rollers		
	Housing material			
By-pass recirculation (type (inter., ext.))	Internal			
Cooling system capacity	With heater-L(qt.)	8.51 (9) Auto, 8.55 (9.04) Man		
	With air cond.-L(qt.)	8.67 (9.16) Auto, 8.76 (9.26) Man		
	Opt. equipment (specify-L(qt.))	8.67 (9.16) Auto, 8.76 (9.26) Man H.D. Rad.		
Water jackets full length of cyl. (yes, no)	Yes			
Water all around cylinder (yes, no)	Yes			
Water jackets open at head face (yes, no)				
Radiator core	Std., A/C, HD	Std.	A/C or H.D.	A/C & H.D.
	Type (cross-flow, etc.)	Cross flow		
	Construction (fin & tube mechanical, braze, etc.)			
	Material, mass [kg (wt. lbs.)]	Copper-brass, high efficiency radiator		
	Width (mm)	304.8	426.7	426.7
	Height (mm)	375.2	375.2	375.2
	Thickness (mm)	31.5	31.5	31.5
	Fins per inch @	4.1	4.6	3.6
Radiator end tank material				
Fan	Std., elec., opt.	Std.	Opt.	
	Number of blades & type (flex, solid, material)	4-Plastic Solid	7-Plastic Solid	
	Diameter & projected width	330.0 (13.0)	360.0 (14.2)	
	Ratio (fan to crankshaft rev.)	1.074:1	1.074:1	
	Fan cutout type	None	Clutch	
	Drive type (direct, remote)	Direct, belt	Direct, belt	
	RPM at idle (elec.)	--	--	
	Motor rating (wattage) (elec.)	--	--	
	Motor switch (type & location) (elec.)	--	--	
	Switch point (temp., pressure) (elec.)	--	--	
Fan shroud (material)	None	Plastic		

@ - Distance between top of fins (mm).

MVMA Specifications Form
Passenger Car
METRIC (U.S. Customary)

Car Line CHEVETTE
 Model Year 1987 Issued 6-86 Revised (e) 9-86

Engine Description/Carb.
 Engine Code

1.6 Liter L-4 (98 CID)
 2-Bbl. Carburetor
 RPO L17

Engine - Fuel System (See supplemental page for details of Fuel Injection, Supercharger, Turbocharger, etc. if used)

Induction type: carburetor, fuel injection system, etc.		Carburetor	
Manufacturer		Holley	
Carburetor	Choke (type)	Electric	
	Idle spd.-rpm (spec. neutral or drive and propane if used)	Manual	800 (Neutral)
		Automatic	700 (Drive)
	Idle A/F mix.		Preset - no adjustment provided
Fuel injection	Point of injection (no.)	--	
	Constant, pulse, flow	--	
	Control (electronic, mech.)	--	
	System pressure (kPa (psi))		
Intake manifold heat control (exhaust or water thermostatic or fixed)		Exhaust	
Air cleaner type	Standard	Replaceable paper element	
	Optional	None	
Fuel pump	Type (elec. or mech.)	Mechanical	
	Location (eng., tank)	Lower - LF of engine	
	Pressure range (kPa (psi))	34-45- (5.0 - 6.5)	

Fuel Tank

Capacity (refill L (gallons))		46.2 (12.2) approximately
Location (describe)		Underside - rear center
Attachment		Underbody strap
Material & Mass (kg (weight lbs))		Steel 7.320 (16.1)
Filler pipe	Location & material	Left rear quarter panel
	Connection to tank	Solder
Fuel line (material)		Steel
Fuel hose (material)		Rubber
Return line (material)		Steel
Vapor line (material)		Steel
Extended range tank	Opt., n.a.	Not Available
	Capacity [L (gallons)]	"
	Location & material	"
	Attachment	"
Auxiliary tank	Opt., n.a.	"
	Capacity [L (gallons)]	"
	Location & material	"
	Attachment	"
	Selector switch or valve	"
Separate fill		"

MVMA Specifications Form Passenger Car

Car Line CHEVETTE
 Model Year 1987 Issued 6-86 Revised (●) 9-86

METRIC (U.S. Customary)

Engine Description/Carb.
 Engine Code

1.6 Liter L-4 (98 CID)
 2-Bbl. Carburetor
 RPO L17

Vehicle Emission Control

Exhaust Emission Control	Type (air injection, engine modifications, other)		Computer Command Control with air injection
	Air Injection	Pump or pulse	Vane
		Driven by	V-Belt
		Air distribution (head, manifold, etc.)	Exh. manifold, air cleaner & converter, CCC controlled
		Point of entry	Exh. man. ports
	Exhaust Gas Recirculation	Type (controlled flow, open orifice, other)	Controlled flow
		Exhaust source	Manifold
		Point of exhaust injection (spacer, carburetor, manifold, other)	Inlet Manifold
	Catalytic Converter	Type	Dual Bed, Ox. & Red.
		Number of	One
		Location(s)	Beneath RF Underbody
		Volume [L (in ³)]	2.782 (170)
		Substrate type	Monolith
	Crankcase Emission Control	Type (ventilates to atmosphere, induction system, other)	
Energy source (manifold vacuum, carburetor, other)		Manifold Vacuum	
Discharges (to intake manifold, other)		Inlet Manifold	
Air inlet (breather cap, other)		Carburetor Air Cleaner	
Evaporative Emission Control	Vapor vented to (crankcase, canister, other)	Fuel tank	Canister
		Carburetor	Canister
	Vapor storage provision		Canister
Electronic system	Closed loop (yes/no)		Yes
	Open loop (yes/no)		No

Engine - Exhaust System

Type (single, single with cross-over, dual, other)		Single
*	Muffler no. & type (reverse flow, straight thru, separate resonator) Material & Mass [kg (weight lbs)]	One, Reverse flow
Resonator no. & type		Not Available
Exhaust pipe	Branch o.d., wall thickness	--
	Main o.d., wall thickness	44.45x.81 (1.75x.032)
	Material & Mass [kg (weight lbs)]	Laminated tubing - steel inner, stainless steel outer @
*	Intermediate pipe	
	o.d. & wall thickness	50.8x1.83 (2.0x.072)
*	Tail pipe	
	o.d. & wall thickness	44.45x1.83 (1.75x.072)
Material & Mass [kg (weight lbs)]		Aluminum coated steel

*Muffler & Tail Pipe Unit 9.072 (20.0)
 @1.673 (3.7)

MVMA Specifications Form Passenger Car

Car Line CHEVETTE
 Model Year 1987 Issued 6-86 Revised (●) _____

METRIC (U.S. Customary)

Engine Description/Carb.
Engine Code

1.6 Liter L-4 (98 CID)
2-Bbl. Carburetor
RPO L17

Transmissions/Transaxle

Manual 3-speed (std., opt., n.a.) (mfr.)	Not Available
Manual 4-speed (std., opt., n.a.) (mfr.)	Base
Manual 5-speed (std., opt., n.a.) (mfr.)	Optional
Manual overdrive (std., opt., n.a.) (mfr.)	Included with 5-speed transmission
Automatic (std., opt., n.a.) (mfr.)	Optional (with converter clutch)
Automatic overdrive (std., opt., n.a.) (mfr.)	Not Available

Manual Transmission/Transaxle

Number of forward speeds	4	5		
Transmission ratios	In first	3.75	3.76	
	In second	2.16	2.18	
	In third	1.38	1.36	
	In fourth	1.00	1.00	
	In fifth	--	.86	
	In overdrive	--	--	
	In reverse	3.82	3.76	
Synchronous meshing (specify gears)	All forward gears			
Shift lever location	Floor mounted			
Lubricant	Capacity [L (pt.)]	1.6 (3.4)	2.132L	
	Type recommended	GL-5	Automatic	
	SAE viscosity number	Summer	80W or 80W-90	Transmission
		Winter	80W or 80W-90	Fluid
Extreme cold		80W or 80W-90		

Clutch (Manual Transmission)

Make, type, engagement (describe) - (hydraulic, cable, rod)	(1) Borg & Beck, Dry Single Plate	
Assist (yes, no percent)		
Type pressure plate springs	Diaphragm	
Total spring load [N (lb.)]	4182 (940) (2)	
No. of clutch driven discs	One	
Clutch facing	Material	Molded Type Asbestos
	Manufacturer	Borg & Beck (3)
	Part number	14032337 (4-Spd) (4)
	Rivets/plate	16 (5)
	Rivet size	3.63 x 5.41 (.143 x .213)
	Outside & inside dia.	180 x 131 (8.0 x 6.0)
	Total eff. area [cm ² (in. ²)]	142 (22.0)
	Thickness	8.128 (.320)
Engagement cushion method	Flat Spring Steel Between Facings	
Release bearing	Type & method of lubrication	Single Row Ball, Packed & Sealed
Torsional damping	Method: springs, friction material	Coil Springs

- (1) Luk Inc., dry single plate for 5-spd.
 (2) 5512 (1240) for 5-spd.
 (3) Luk Inc., for 5-spd.

- (4) - 14061690 for 5-spd.
 (5) - 18 for 5-spd.

MVMA Specifications Form Passenger Car

Car Line CHEVETTE
 Model Year 1987 Issued 6-86 Revised (●) _____

METRIC (U.S. Customary)

Engine Description/Carb.
 Engine Code

1.6 Liter L-4 (98 CID)
 2-Bbl. Carburetor
 RPO L17

Automatic Transmission/Transaxle

Trade name		3-Speed Automatic
Type and special features (describe)		Torque converter with converter clutch 180c
Selector	Location	Floor
	Ltr. No. designation	P-R-N-D-2-1
Gear ratios	1st	2.40
	2nd	1.48
	3rd	1.00 (converter clutch engagement)
	4th	Not available
	Reverse	1.92
Max. upshift speed - drive range [km/h (mph)]		1-2=61 (38), 2-3=101 (63)
Max. kickdown speed - drive range [km/h (mph)]		3-2=87 (54), 2-1=55 (34)
Min. overdrive speed [km/h (mph)]		Not Available
Torque converter	Number of elements	3
	Max. ratio at stall	Not Available
	Type of cooling (air, liquid)	Liquid
	Nominal diameter	245 (9.65)
Lubricant	Capacity [refill L (pt.)]	2.30
	Type Recommended	Dexron II
Oil cooler (std., opt., NA, internal, external, air, liquid)		Standard Integral with radiator.

Axle or Front Wheel Drive Unit

Type (front, rear)		Rear	
Description		Semi-floating with hypoid overhung pinion gear	
Limited slip differential (type)		Not Available	
Drive pinion offset		28.4 (1.12)	
Drive pinion (type)		Hypoid gear	
No. of differential pinions		Two	
Pinion / differential adjustment (shim, other)		Shims	
Pinion / differential bearing adjustment (shim, other)		Collapsible Sleeve	
Driving wheel bearing (type)		Direct Single Row Ball	
Lubricant	Capacity [L (pt.)]	0.8 (1.75)	
	Type recommended	GL-5 Gear Lubricant	
	SAE viscosity number	Summer	80W or 80W-90
		Winter	80W or 80W-90
Extreme cold		80W or 80W-90	

Axle or Transaxle Ratio and Tooth Combinations (See 'Power Teams' for axle ratio usage.)

Axle ratio (or overall top gear ratio)		(:1) 3.36, 3.62
No. of teeth	Pinion	10
	Ring gear or gear	37
Ring gear o.d.		165 (6.50)
Transaxle	Transfer gear ratio	--
	Final drive ratio	--

MVMA Specifications Form Passenger Car

METRIC (U.S. Customary)

Car Line CHEVETTE
 Model Year 1987 Issued 6-86 Revised (•) _____

Engine Description/Carb.
Engine Code

2-Door Hatchback Coupe 1TB08	4-Door Hatchback Sedan 1TB68
---------------------------------	---------------------------------

Propeller Shaft – Rear Wheel Drive

Manufacturer Type (straight tube, tube-in-tube, internal-external damper, etc.)		(a) (b)			
Outer diam. x length* x wall thickness	Manual 3-speed trans.	Not Available			
	Manual 4-speed trans.	50.8x586.0x1.40	50.8x732.0x1.40* 50.8x586.0x1.40#	50.8x662.2x1.40	50.8x808.2x1.40
	Manual 5-speed trans.	50.8x535.2x1.40 (with L17) 50.8x586.0x1.40 (with LJ5)		50.8x611.4x1.40 (with L17) 50.8x662.2x1.40 (with LJ5)	
	Overdrive	Not available			
	Automatic transmission	50.8 x 586.0 x 1.40 (2.0 x 23.1 x .055)		50.8 x 662.2 x 1.40	
Inter- mediate bearing	Type (plain, anti-friction)	Anti-Friction			
	Lubrication (fitting, prepack)	Prepacked			
Slip yoke	Type	Splined			
	Number of teeth	27			
	Spline o.d.	28 (1.12)			
Universal joints	Make and mfg. no.	Front	Saginaw 23		
		Rear	Saginaw 23		
	Number used	Two			
	Type (ball and trunnion, cross)	Cross			
	Rear attach (u-bolt, clamp, etc.)	Strap & bolt			
	Bearng	Type (plain, anti-friction)	Anti-Friction		
Lubrication (fitting, prepack)		Prepacked			
Drive taken through (torque tube, arms or springs)		Control Arms			
Torque taken through (torque tube, arms or springs)		Torque Tube			

* Centerline to centerline of universal joints, or to centerline of rear attachment.

(a) Straight tube attached to 'U' joints to a solid steel pinion extension.
A torque tube housing extension shaft is bolted.

(b) Tuned torsional damper used with automatic transmission.
* Without A/C # With A/C

MVMA Specifications Form Passenger Car

Car Line CHEVETTE
Model Year 1987 Issued 6-86 Revised (e) _____

METRIC (U.S. Customary)

Body Type And/Or
Engine Displacement

2-Door Hatchback Coupe 1T808	4-Door Hatchback Sedan 1T868
---------------------------------	---------------------------------

Suspension - General

Car leveling	Std. opt. n.a.	Not Available
	Type (air, hyd., etc.)	Not Available
	Manual auto controlled	Not Available
Provision for brake dip control		Front Suspension Geometry
Provision for accel. squat control		Rear Suspension Geometry
Provisions for car jacking		Bumper Slots in Bottom of Front & Rear Bumper Face Bars
Shock absorber (front & rear)	Type	Direct, Double Acting, Hydraulic
	Make	Delco
	Piston diameter	25.0 (1.0)
	Rod diameter	13.49 (0.53)

Suspension - Front

Type and description		Independent SLA
Travel	Full jounce	--
	Full rebound	87.7 mm (3.4 in)
Spring	Type (coil, leaf, other) & material	91.4 mm (3.6 in)
	Insulators (type & material)	Coil, Steel Alloy
	Size (coil design height & i.d., bar length x dia.)	209.3 (8.24) x 81.7 (3.22) x 2690.8 (105.9) x 12.06 (0.475)
	Spring rate [N/mm (lb./in.)]	28.0/59.4 (160.0/339.0)
	Rate at wheel [N/mm (lb./in.)]	13.04 (74.5)
Stabilizer	Type (link, linkless, frameless)	Link
	Material & bar diameter	HR Steel - 22 (.87)

Suspension - Rear

Type and description		Solid Axle, Positioned by Links, Torque Tube & Track Bar	
Travel	Full jounce	86.0 mm (3.4 in)	
	Full rebound	136.0 mm (5.3 in)	
Spring	Type (coil, leaf, other) & material	Coil, Steel Alloy	
	Size (length x width, coil design height & i.d., bar length & dia.)	233.7 (9.20) x 119.0 (4.69) x 2301.9 (90.6) x 13.19 (0.519)	
	Spring rate [N/mm (lb./in.)] *	23.5/28.1-29.2/ 33 (134.0/160-167/188)	
	Rate at wheel [N/mm (lb./in.)]	20.3 (116.0)	
	Insulators (type & material)	Not Available	
	If leaf	No. of leaves	Not Applicable
		Shackle (comp. or tens.)	Not Applicable
Stabilizer	Type (link, linkless, frameless)	Not Available	
	Material & bar diameter	Not Available	
Track bar (type)		Tubular, with Rubber Bushings	

*Spring Rate: Constant to constant 28.0-59.4, Variable to variable 23.5/28.1-29.2/33.0

MVMA Specifications Form Passenger Car

METRIC (U.S. Customary)

Car Line CHEVETTE
Model Year 1987 Issued 6-86 Revised (●) _____

Body Type And/Or
Engine Displacement

2-Door Hatchback Coupe 1T808	4-Door Hatchback Sedan 1T868
---------------------------------	---------------------------------

Brakes - Service

Description		Single caliper disc front, duo-servo drum rear		
Manufacturer and brake type (std., opt., n.a.)	Front (disc or drum)	Disc		
	Rear (disc or drum)	Drum		
Self-adjusting (std., opt., n.a.)		Standard		
Special valving	Type (proportion, delay, metering, other)	Proportioning		
Power brake (std., opt., n.a.)		Optional		
Booster type (remote, integral, vac., hyd., etc.)		Integral		
Vacuum source (inline, pump, etc.)		Inline (Intake manifold)		
Vacuum reservoir (volume in. ³)		None		
Vacuum pump-type (elec, gear driven, belt driven, if other so state)		None		
Anti-lock device type (std., opt., n.a.) (F/R)		Not available		
Effective area [cm ² (in. ²)]*		514.9 (79.83)		
Gross lining area [cm ² (in. ²)]**(F/R)		Not Available		
Swept area [cm ² (in. ²)]*** (F/R)		1804.5 (279.77)		
Rotor	Outerworking diameter	F/R	246 (9.68) / --	
	Inner working diameter	F/R	143.8 (5.66) / --	
	Thickness	F/R	11 (.433) / --	
	Material & type (vented/solid)	F/R	Cast Iron, Solid / --	
Drum	Diameter & width	F/R	-- / 200 (7.87)	
	Type and material	F/R	-- / Cast Iron	
Wheel cylinder bore		52 (2.05) / 17.5 (0.69)		
Master cylinder	Bore/stroke	F/R	22 (0.87) / 33 (1.30)	
Pedal arc ratio		6.5:1 Manual; 4.75:1 Power		
Line pressure at 445 N(100 lb.) pedal load [kPa (psi)]		Not Available		
Lining clearance		F/R	Self Adjusting/Self Adjusting	
Brake lining	Front wheel	Bonded or riveted (rivets/seg.)		Integrally Molded
		Rivet size		Not Applicable
		Manufacturer		Delco Moraine
		Lining code*****		DM 8034
		Material		Semi - Metallic
		****	Primary or out-board	117 x 54.7 x 10.9 (4.6 x 2.15 x .43)
	Size	Secondary or in-board	123 x 48.8 x 11.4 (4.8 x 1.92 x .45)	
	Shoe thickness (no lining)		Not Available	
	Rear wheel	Bonded or riveted (rivets/seg.)		Riveted
		Manufacturer		Inland Div. GMC
		Lining Code*****		Primary IN4035, Secondary IN4050
		Material		Organic
		****	Primary or out-board	167.7 x 43.9 x 3.8 (6.6 x 1.73 x 0.15)
Size		Secondary or in-board	203.3 x 43.9 x 4.8 (8.0 x 1.73 x 0.19)	
Shoe thickness (no lining)		2.75 (.106)		

*Excludes rivet holes, grooves, chamfers, etc.

**Includes rivet holes, grooves, chamfers, etc.

***Total swept area for four brakes. (Drum brake: Widest lining contact width for each brake x its contact circumference.)
(Disc brake: Square of Outer Working Dia. minus Square of inner Working Dia. multiplied by Pi/2 for each brake.)

****Size for drum brakes includes length x width x thickness.

*****Manufacturer I.D., catalog or formulation designation and coefficient of friction classification.

MVMA Specifications Form Passenger Car

METRIC (U.S. Customary)

Car Line CHEVETTE
 Model Year 1987 Issued 6-86 Revised (●) _____

Body Type And/OR
Engine Displacement

2-Door Hatchback Coupe 1TB08	4-Door Hatchback Sedan 1TB68
---------------------------------	---------------------------------

Tires And Wheels (Standard)

Tires	Size (load range, ply)		P155/80R-13 (BW)
	Type (bias, radial, etc.)		Steel belted radial
	Inflation pressure (cold) for recommended max. vehicle load	Front [kPa (psi)]	205 (30)
		Rear [kPa (psi)]	205 (30)
Rev. mile—at 70 km/h (45 mph)		570	
Wheels	Type & material		Short Yoke Disc, Steel
	Rim (size & flange type)		13 x 5
	Wheel offset		37 mm (1.46)
	Attachment	Type (bolt or stud)	Stud
		Circle diameter	100 mm (3.94)
Number & size		4 hex nuts - M12 x 1.5	
Spare	Tire and wheel (same, if other describe)		14 x 4 (49 mm); compact tire - T115/70D-14 (60/415)
	Storage position & location (describe)		Flat under rear load floor

Tires And Wheels (Optional)

Size (load range, ply)		P155/80R-13 (WW)
Type (bias, radial, etc.)		Steel belted radial
Wheel (type & material)		Short yoke disc, steel
Rim (size, flange type and offset)		13 x 5, 37 mm (1.46)
Size (load range, ply)		
Type (bias, radial, etc.)		
Wheel (type & material)		
Rim (size, flange type and offset)		
Size (load range, ply)		
Type (bias, radial, etc.)		
Wheel (type & material)		
Rim (size, flange type and offset)		
Spare tire and wheel (if configuration is different than road tire or wheel, describe optional spare tire and/or wheel location & storage position)		

Brakes - Parking

Type of control		Grip handle
Location of control		On floor between seats
Operates on		Rear service brakes
If separate from service brakes	Type (internal or external)	--
	Drum diameter	--
	Lining size (length x width x thickness)	--

MVMA Specifications Form Passenger Car

Car Line CHEVETTE
 Model Year 1987 Issued 6-86 Revised (*) _____

METRIC (U.S. Customary)

Body Type And/Or
Engine Displacement

2-Door Hatchback Coupe
1TB08

4-Door Hatchback Sedans
1TB68

Steering

Manual (std., opt., n.a.)		Standard		
Power (std., opt., n.a.)		Optional (a)		
Adjustable steering wheel/column (tilt, telescope, other)	Type	Tilt-Universally Jointed Steering Shaft at Base		
	Manufacturer	of Steering Wheel		
	(Std., opt., n.a.)	Optional		
Wheel diameter** (W9) SAE J1100	Manual	381 (15.0)		
	Power	381 (15.0)		
Turning diameter m (ft.)	Outside front	Wall to wall (l. & r.)	10.5 (34.3) 10.6 (34.9)	
		Curb to curb (l. & r.)	9.2 (30.2) 9.4 (30.8)	
	Inside rear	Wall to wall (l. & r.)	5.0 (16.5)	
		Curb to curb (l. & r.)	4.8 (15.9)	
Scrub Radius*		Not Available		
Manual	Gear	Type	Rack & Pinion	
		Manufacturer	Saginaw Steering Gear	
	Ratios	Gear	Not Applicable	
		Overall	18.4:1	
No. wheel turns (stop to stop)		3.6		
Power	Type (coaxial, linkage, etc.)		Not Available	
	Manufacturer		Saginaw Steering Gear	
	Gear	Type	Rack & Pinion with Integral Power Unit	
		Ratios	Gear	Not Applicable
			Overall	18.0:1
	Pump (drive)		'V' Belt Off Crankshaft Pulley	
No. wheel turns (stop to stop)		3.5		
Linkage	Type		Rack and Pinion	
	Location (front or rear of wheels, other)		Front	
	Tie rods (one or two)		Two	
Steering axis	Inclination at camber (deg.)		7.55	
	Bearings (type)	Upper	Ball Joint	
		Lower	Ball Joint	
		Thrust	None	
Steering spindle & joint type		Forged Knuckle w/Upper & Lower Spherical Joints		
Wheel spindle/hub	Diameter	Inner bearing	26.97 (1.06)	
		Outer bearing	17.45 (0.69)	
	Thread (size)		3/4 - 20 NEF (MIG-T)	
	Bearing (type)		Tapered Roller	

*The horizontal distance in the front elevation between wheel centerline and kingpin (ball joint) axis at ground.

**See Page 21.

(a) Automatic transmission must be ordered.

MVMA Specifications Form Passenger Car

Car Line CHEVETTE
 Model Year 1987 Issued 6-86 Revised (•) _____

METRIC (U.S. Customary)

Body Type And/Or
Engine Displacement

2-Door Hatchback Coupe 1TB08	4-Door Hatchback Sedan 1TB68
---------------------------------	---------------------------------

Wheel Alignment

Front wheel at curb mass (wt.)	Service checking	Caster (deg.)	+3.0° to +7.0°
		Camber (deg.)	-.5° to +.9°
		Toe-in [outside track-mm (in.)]	-.02° to +.14° (-.5 mm to +3.5 mm)
	Service reset*	Caster	+5.0° +/- 1°
		Camber	+2° +/- .4°
		Toe-in	+0.06° +/- .04° (+1.5 +/- 1.00 mm)
	Periodic M.V. in-spection	Caster	+3.0° to +7.0°
		Camber	-1.25° to +1.75°
		Toe-in	-.02° to +.14° (-.5 mm to +3.5 mm)
Rear wheel at curb mass (wt.)	Service checking	Camber (deg.)	Not Applicable
		Toe-in [outside track-mm (in.)]	" "
	Service reset*	Camber	" "
		Toe-in	" "
	Periodic M.V. in-spection	Camber	" "
		Toe-in	" "

* Indicates pre-set, adjustable, trend set or other.

Electrical – Instruments and Equipment

Speedometer	Type (analog, digital, std., opt.)	Circular Dial with Pointer
	Trip odometer (std., opt., n.a.)	Not Available
EGR maintenance indicator		" "
Charge indicator	Type	Tell-Tale Warning Light
	Warning device (light, audible)	" " " "
Temperature indicator	Type	Tell-Tale Warning Light
	Warning device (light, audible)	" " " "
Oil pressure indicator	Type	Tell-Tale Warning Light
	Warning device (light, audible)	" " " "
Fuel indicator	Type	Electric Gauge with Pointer
	Warning device (light, audible)	" " " "
Windshield wiper	Type (standard)	Electric 2-Speed
	Type (optional)	Not Available
	Blade length	403.4 (15.9 in)
	Swept area (cm ² (in. ²))	3951 (612.5 in ²)
Windshield washer	Type (standard)	Electric Push-Button, in end of turn signal lever.
	Type (optional)	Not Available
	Fluid level indicator (light, audible)	" "
Rear window wiper, wiper/washer (std., opt., n.a.)		
Horn	Type	Electric Vibrator
	Number used	One
Other		Parking Brake warning light and brake failure warning light, restraint system warning light and buzzer.

MVMA Specifications Form Passenger Car

Car Line CHEVETTE
Model Year 1987 Issued 6-86 Revised (•) _____

METRIC (U.S. Customary)

Engine Description/Carb.
Engine Code

1.6 Liter L-4 (98 CID)
2-Bbl. Carburetor
RPO L17

Electrical - Supply System

Battery	Manufacturer	Delco
	Model, std., (opt.)	70-330 Std. (man. trans.)*
	Voltage	12 Volt
	Amps at 0°F cold crank	330 std. (man. trans.)@
	Minutes-reserve capacity	60 min(man), 75 min (Auto)+
	Amp/hrs. - 20 hr. rate	--
	Location	Engine compartment, R.F.
Alternator	Manufacturer	Delco Remy
	Rating	42 amps
	Ratio (alt. crank/rev.)	2.1
	Optional (type & rating)	None
Regulator	Type	Micro circuit; internal

Electrical - Starting System

Start, motor	Current drain at 0°F -20°F	235 Manual, 270 automatic
	Engagement type	Positive shift solenoid
Motor drive	Pinion engages from (front, rear)	Rear

Electrical - Ignition System

Type	Electronic (std., opt., n.a.)	Not available	
	Other (specify)	High Energy Ignition (HEI)	
Coil	Make	Delco Remy	
	Model	1115454	
	Current	Engine stopped - A	0
		Engine idling - A	5.5 Max
Spark plug	Make	AC	
	Model	R42CTS	
	Thread (mm)	M14x1.25	
	Tightening torque (N-m (lb, ft))	9-20 (7-15)	
	Gap	0.889 (.035)	
	Number per cylinder	Delco Remy	
Distributor	Make	1103504	
	Model		

Electrical - Suppression

Locations & type Internal alternator capacitor, non-metallic high-tension ignition cables, resistor spark plugs, ignition coil by-pass capacitor, internal AC blower motor by-pass capacitor & A/C compression diode, with radio provisions; hood grounding clip, engine to dash panel ground strap, fuse block capacitor and on "heater only" blower motors and coax capacitor.

* - 70-385 Std. (Auto. Trans.) + - 90 min. Opt.
75-430 Opt.
@ - 385 Std. (Auto. Trans.), 430 Opt.

MVMA Specifications Form
Passenger Car
METRIC (U.S. Customary)

Car Line CHEVETTE
 Model Year 1987 Issued 6-86 Revised (•) _____

Body Type	2-Door Hatchback Coupe 1TB08	4-Door Hatchback Sedan 1TB68
------------------	---------------------------------	---------------------------------

Body

Structure	Steel roof panel with reinforcing bow. Box section roof rails, windshield and rear window headers, door and roof panels. Double-walled cowl welded to instrument panel, floor and dash panel. Double-panel door, hood and hatch panel.
Bumper system front - rear	Energy absorber energy management system. GM 5 mph impact.
Anti-corrosion treatment	Designed in anti-corrosion build measures. Corrosion retarding dipping and spraying. Zinc treated metals in critical areas. Plastics, waxes and sealers to joints. Plastisol applied to lower body areas.

Body - Miscellaneous Information

Type of finish (lacquer, enamel, other)	Acrylic Lacquer	
Hood	Hinge location (front, rear)	Rear
	Type (counterbalance, prop)	Prop Rod
	Release control (internal, external)	Internal
Trunk lid	Type (counterbalance, other)	Not Applicable
	Internal release control (elec. mech., n.a.)	Not Applicable
Hatch-back lid	Type (counterbalance, other)	Telescoping gas strut - left side
	Internal release control (elec., mech., n.a.)	Not Available
Station wagon		
Vent window control (crank, friction, pivot, power)	Front	None
	Rear	Friction Pivot None
Seat cushion type (e.g., 60/40, bucket, bench, wire, foam etc.)	Front	Bucket seat formed foam pad
	Rear	Bench seat formed foam pad
	3rd seat	None
Seat back type (e.g., 60/40, bucket, bench, wire, foam etc.)	Front	Bucket seat, Formed foam pad
	Rear	Bench seat, full folding formed foam pad
	3rd seat	None

MVMA Specifications Form
Passenger Car
METRIC (U.S. Customary)

Car Line CHEVETTE
 Model Year 1987 Issued 6-86 Revised (●) _____

Body Type

2-Door Hatchback Coupes 1TB08	4-Door Hatchback Sedans 1TB68
----------------------------------	----------------------------------

Restraint System

Active restraint system	Standard/optional	Standard
	Type and description	3 point shoulder and lap belt for driver and front passenger. Lap belt for rear passengers.
	Location	Front - (2); Rear - (2)
Passive seat belts	Standard/optional	Not Available
	Power/manual	"
	2 or 3 point	"
	Knee bar/lap belt	"

Frame

Type and description (separate frame, unitized frame, partially-unitized frame)	Unitized frame with crossmember reinforcement
---	---

Glass	SAE Ref. No.		
Windshield glass exposed surface area [cm ² (in. ²)]	S1	6735 (1043.9)	
Side glass exposed surface area [cm ² (in. ²)] - total 2-sides	S2	9926 (1538.5)	10904 (1690.1)
Backlight glass exposed surface area [cm ² (in. ²)]	S3	5835 (904.4)	
Total glass exposed surface area [cm ² (in. ²)]	S4	22496 (3486.9)	23474 (3638.5)
Windshield glass (type)		Curved - Laminated Plate	
Side glass (type)		Curved - Tempered Plate	
Backlight glass (type)		Curved - Tempered Plate	

MVMA Specifications Form
Passenger Car
METRIC (U.S. Customary)

Car Line CHEVETTE
 Model Year 1987 Issued 6-86 Revised (●) _____

Body Type	2-Door Hatchback Coupe 1TB08	4-Door Hatchback Sedan 1TB68
------------------	---------------------------------	---------------------------------

Convenience Equipment (standard, optional, n.a.)

Air conditioning (manual, auto temp control)	Optional (manual control)	
Clock (digital, analog)	Not Available	
Compass thermometer	"	
Console (floor, overhead)	Standard, floor	
Defroster, elec. backlight	Optional	
Electronic	Diagnostic monitor (integrated, individual)	Not Available
	Instrument cluster (list instruments)	"
	Keyless entry	"
	Trip/finder (avg. spd., fuel)	"
	Voice alert (list items)	"
	Other	"
	--	
Fuel door lock (remote, key, electric)	Not Available	
Lamps	Auto head on - off delay, dimming	"
	Cornering	"
	Courtesy (map, reading)	"
	Door lock, ignition	"
	Engine compartment	"
	Fog	"
	Glove compartment	"
	Trunk	"
	Other	--
	--	
Mirrors	Day night (auto, man.)	Standard, manual
	L.H. (remote, power, heated)	Remote, optional
	R. H. (convex, remote, power, heated)	Convex manual, optional
	Visor vanity (RH L.H. illuminated)	Not Available
Parking brake-auto release (warning light)	Standard, in lower area of speedometer	
Power equipment	Door locks - deck lid - specify	Not Available
	Seat (2-4-6 way) heated (driver, pass, other) lumbar, hip, thigh support (power, manual) reclining (driver, pass) memory (1-2 preset, recline)	"
	Side windows	"
	Vent windows	"
	Rear window	"
		--
Radio systems	Antenna (location, whip, w shield, power)	Whip, R.H. frt. fender
	AM, FM stereo, tape, CB	AM standard, Opt. AM/FM and AM/FM stereo
	Speaker (number, location) Premium sound	2 w/stereo radio, 1-frt, 2-rr quarter
Roof open air fixed (flip-up, sliding, "T")	Not Available	
Speed control device	"	
Speed warning device (light, buzzer, etc.)	"	
Tachometer (rpm)	"	
Telephone system - mobile		
Theft protection-type	Lock mounted on steering column; locks steering wheel and ignition.	

MVMA Specifications Form

Passenger Car

Car Line CHEVETTE
 Model Year 1987 Issued 6-86 Revised (e) _____

METRIC (U.S. Customary) Car and Body Dimensions

See Key Sheets for definitions

All dimensions to ground are for comparative purposes only. Dimensions are to be shown for all base body models of each car line.
 SAE Ref. no. refers to the definition published in SAE Recommended Practice J1100 "Motor Vehicle Dimensions," unless otherwise specified.

Body Type	SAE Ref. No.	2-DOOR HATCHBACK COUPE 1TB08	4-DOOR HATCHBACK SEDAN 1TB68
Width			
Tread (front)	W101	1300 (51.2)	
Tread (rear)	W102	1300 (51.2)	
Vehicle width	W103	1570 (61.8)	
Body width at Sg RP (front)	W117	1546 (60.9)	
Vehicle width (front doors open)	W120	3384 (133.2)	3048 (120.0)
Vehicle width (rear doors open)	W121	--	2974 (117.1)
Front fender overall width	W106	1548 (60.9)	
Rear fender overall width	W107	1570 (61.8)	
Tumble-home (deg.)	W122	20.5°	
Length			
Wheelbase	L101	2394 (94.3)	2471 (97.3)
Vehicle length	L103	4111 (161.9)	4188 (164.9)
Overhang (front)	L104	787 (31.0)	
Overhang (rear)	L105	930 (36.6)	
Upper structure length	L123	2510 (98.8)	2586 (101.8)
Rear wheel C.L. "X" coordinate	L127	2179 (95.5)	
Cowl point "X" coordinate	L125	306 (12.0)	
Front end length at centerline	L126	885 (34.8)	
Rear end length at centerline	L129	196 (7.7)	
Height **			
Passenger distribution (front/rear)	PD1.2.3		**
Trunk/cargo load			**
Vehicle height	H101	1342 (52.8)	1342 (52.8)
Cowl point to ground	H114	894 (35.2)	893 (35.1)
Deck point to ground	H138		
Rocker panel-front to ground	H112	205 (8.1)	205 (8.1)
Bottom of door closed-front to grd.	H133	270 (10.6)	269 (10.6)
Rocker panel-rear to ground	H111	203 (8.0)	204 (8.0)
Bottom of door closed-rear to grd.	H135	--	
Windshield slope angle	H122	52.8	
Backlight slope angle	H121	62.5	
Ground Clearance **			
Front bumper to ground	H102	325 (12.8)	323 (12.7)
Rear bumper to ground	H104	331 (13.0)	332 (13.1)
Bumper to ground (front at curb mass (wt.))	H103	356 (14.0)	
Bumper to ground (rear at curb mass (wt.))	H105	348 (13.7)	
Angle of approach (degrees)	H106	18.1°	18.0°
Angle of departure (degrees)	H107	21.4°	21.5°
Ramp breakover angle (degrees)	H147	18.0°	17.4°
Axle differential to ground (front / rear)	H153	156 (6.1)	
Min. running ground clearance	H156	142 (5.6)	141 (5.6)
Location of min. run. grd. clear.		K-Brace under front crossmember	

**All Vehicle Height And Ground Clearances Are Made Using EPA Loaded Vehicle Weight, Loading Conditions.

EPA LOADED VEHICLE WEIGHT is The Base Vehicle Weight Plus All Coolant And Fluids Necessary For Operation Plus 100% Of The Fuel Capacity, Plus The Weight Of All Options And Accessories Which Weigh Three Pounds Or More And Which Are Sold On At Least 33% Of The Car Line, Plus Two Occupants.

MVMA Specifications Form
Passenger Car
METRIC (U.S. Customary)
Car and Body Dimensions

Car Line CHEVETTE
 Model Year 1987 Issued 6-86 Revised (•) _____

See Key Sheets for definitions

Body Type

SAE Ref. No.	2-DOOR HATCHBACK COUPE 1TB08	4-DOOR HATCHBACK SEDAN 1TB68
--------------	---------------------------------	---------------------------------

Front Compartment

Sg RP front, "X" coordinate	L31	1118 (44.0)	
Effective head room	H61	959 (37.8)	962 (37.9)
Max. eff. leg room (accelerator)	L34	1058 (41.7)	
SgRP to heel point	H30	259 (10.2)	
SgRP to heel point	L53	828 (32.6)	
Back angle	L40	26.5	
Hip angle	L42	97.0	
Knee angle	L44	123.0	
Foot angle	L46	97.0	
Design H-point front travel	L17	134 (5.3)	
Normal driving & riding seat track trvl.	L23	134 (5.3)	
Shoulder room	W3	1273 (50.1)	1266 (49.8)
Hip room	W5	1268 (49.9)	1256 (49.4)
** Upper body opening to ground	H50	1240 (48.8)	
Steering wheel maximum diameter	W9	383 (15.1)	
Steering wheel angle	H18	30.2	
Accel. heel pt. to steer. whl. cntr	L11		
Accel. heel pt. to steer. whl. cntr	H17		
Steering wheel to C/L of thigh	H13	91 (3.6)	
Steering wheel torso clearance	L7	365 (14.4)	
Headlining to roof panel (front)	H37	29 (1.1)	27 (1.1)
Undepressed floor covering thickness	H67	25 (1.0)	

All Interior Dimensions Are Measured With The Seating Reference Point (SgRP) Full Rear And mm Upward Of Rearmost Seat Position.

Rear Compartment

Sg RP Point couple distance	L50	678 (26.7)	754 (29.7)
Effective head room	H63	942 (37.1)	937 (36.9)
Min. effective leg room	L51	777 (30.6)	864 (34.0)
Sg RP (second to heel)	H31	268 (10.6)	
Knee clearance	L48	-69 (-2.7)	1 (0.0)
Compartment room	L3	584 (23.0)	664 (26.1)
Shoulder room	W4	1254 (49.4)	1256 (49.4)
Hip room	W6	1045 (41.1)	1047 (41.2)
** Upper body opening to ground	H51	--	
Back angle	L41	25.0	
Hip angle	L43	80.5	82.0
Knee angle	L45	81.0	86.0
Foot angle	L47	117.5	119.0
Headlining to roof panel (second)	H38	21 (0.8)	27 (1.1)
Depressed floor covering thickness	H73	12 (0.5)	

Luggage Compartment

Usable luggage capacity [L (cu. ft.)]	V1	--	
** Liftover height	H195	754 (29.7)	758 (29.8)

Interior Volumes (EPA Classification)

Vehicle class (subcompact, compact, etc.)		Sub-compact	
Interior volume index (cu. ft.)		77.1	80.3
Trunk/cargo index (cu. ft.)		9.7	9.7

All linear dimensions are in millimeters (inches).
 ** EPA Loaded Vehicle Weight, Loading Conditions

MVMA Specifications Form
Passenger Car
METRIC (U.S. Customary)
Car and Body Dimensions

Car Line CHEVETTE
 Model Year 1987 Issued 6-86 Revised (•) 10-86

See Key Sheets for definitions

Body Type

SAE Ref. No.	2-DOOR HATCHBACK COUPE 1TB08	4-DOOR HATCHBACK SEDAN 1TB68
--------------	---------------------------------	---------------------------------

Station Wagon – Third Seat

Sg RP couple distance	L85	NOT
Shoulder room	W85	APPLICABLE
Hip room	W86	
Effective leg room	L86	
Effective head room	H86	
Sg RP to heel point	H87	
Knee clearance	L87	
Seat facing direction	SD1	
Back angle	L88	
Hip angle	L89	
Knee angle	L90	
Foot angle	L91	

Station Wagon – Cargo Space

Cargo length (open front)	L200	
Cargo length (open second)	L201	NOT
Cargo length (closed front)	L202	APPLICABLE
Cargo length (closed second)	L203	
Cargo length at belt (front)	L204	
Cargo length at belt (second)	L205	
Cargo width (wheelhouse)	W201	
Rear opening width at floor	W203	
Opening width at belt	W204	
• Max. rear opening width above belt	W205	
Cargo height	H201	
Rear opening height	H202	
Tailgate to ground height	H250	
Front seat back to load floor height	H197	
Cargo volume index [m ³ (ft. ³)]	V2	
Hidden cargo volume [m ³ (ft. ³)]	V4	
Cargo volume index-rear of 2-seat	V10	

Hatchback – Cargo Space

Cargo length at front seatback height	L208	1024 (40.3)	1099 (43.3)
Cargo length at floor (front)	L209	1471 (57.9)	1549 (61.0)
Cargo length at second seatback height	L210	727 (28.6)	
Cargo length at floor (second)	L211	809 (31.9)	
Front seatback to load floor height	H197	490 (19.3)	
Second seatback to load floor height	H198	286 (11.3)	
Cargo volume index [m ³ (ft. ³)]	V3	767 (27.1)	815 (28.8)
Hidden cargo volume [m ³ (ft. ³)]	V4	--	
Cargo volume index-rear of 2-seat	V11	275 (9.7)	276 (9.7)

Aerodynamics*

Wheel lip to ground, front	594 (23.4)	593 (23.3)
Wheel lip to ground, rear	595 (23.4)	596 (23.5)
Frontal area [m ² (ft. ²)]	1.76 (18.9)	
Drag coefficient (Cd)		

* EPA Loaded Vehicle Weight, Loading Conditions
 All linear dimensions are in millimeters (inches) unless otherwise noted.

MVMA Specifications Form
Passenger Car
METRIC (U.S. Customary)

Car Line CHEVETTE
 Model Year 1987 Issued 6-86 Revised (●) _____

Body Type

2-DOOR HATCHBACK COUPE
1TB08

4-DOOR HATCHBACK SEDAN
1TB68

Vehicle Fiducial Marks

Fiducial Mark Number*	Define Coordinate Location															
Front	<p>X - Fiducial mark to vertical base grid line-front, measured horizontally from the base grid line to the front fiducial mark located on top of the front seat adjuster mounting bolt.</p> <p>Y - Fiducial mark to centerline of car-front, width measurement made from centerline of car to fiducial mark located on top of the front seat adjuster mounting bolt.</p> <p>Z - Fiducial mark to horizontal base grid-front, measured vertically from base grid line to front fiducial mark located on top of the front seat adjuster mounting bolt.</p>															
Rear	<p>X - Fiducial mark to vertical base grid line-rear measured horizontally from the base grid line to the rear fiducial mark located on rail (compartment pan - longitudinal).</p> <p>Y - Fiducial mark to centerline of car-rear, width measurement made from centerline of car to fiducial mark located on the rail (compartment pan - longitudinal).</p> <p>Z - Fiducial mark to horizontal base grid line-rear, measured vertically from base grid line to the rear fiducial mark located on the rail (compartment pan - longitudinal).</p>															
Fiducial Mark Number																
Front	<table border="1"> <tr> <td>W21</td> <td>504 (19.8)</td> <td></td> </tr> <tr> <td>L54</td> <td>750 (29.5)*</td> <td></td> </tr> <tr> <td>H81</td> <td>150 (5.9)#</td> <td></td> </tr> <tr> <td>H161</td> <td>290 (11.4)</td> <td></td> </tr> <tr> <td>** H163</td> <td>264 (10.4)</td> <td></td> </tr> </table>	W21	504 (19.8)		L54	750 (29.5)*		H81	150 (5.9)#		H161	290 (11.4)		** H163	264 (10.4)	
W21	504 (19.8)															
L54	750 (29.5)*															
H81	150 (5.9)#															
H161	290 (11.4)															
** H163	264 (10.4)															
Rear	<table border="1"> <tr> <td>W22</td> <td>195 (7.7)</td> <td></td> </tr> <tr> <td>L55</td> <td>2850 (112.2)*</td> <td>2926 (115.2)*</td> </tr> <tr> <td>H82</td> <td>278 (10.9)#</td> <td></td> </tr> <tr> <td>H162</td> <td>423 (16.7)</td> <td></td> </tr> <tr> <td>** H164</td> <td>406 (16.0)</td> <td></td> </tr> </table>	W22	195 (7.7)		L55	2850 (112.2)*	2926 (115.2)*	H82	278 (10.9)#		H162	423 (16.7)		** H164	406 (16.0)	
W22	195 (7.7)															
L55	2850 (112.2)*	2926 (115.2)*														
H82	278 (10.9)#															
H162	423 (16.7)															
** H164	406 (16.0)															
	<p>* Vertical Base Grid 1100 mm Line. # Horizontal Base Grid 100 mm Line.</p>															

* Reference - SAE Recommended Practice, J182, Motor Vehicle Fiducial Marks.

All linear dimensions are in millimeters (inches).

** EPA Loaded Vehicle Weight, Loading Conditions

MVMA Specifications Form
Passenger Car
METRIC (U.S. Customary)

Car Line CHEVETTE
 Model Year 1987 Issued 6-86 Revised (●) _____

Body Type

2-DOOR HATCHBACK COUPE 1TB08	4-DOOR HATCHBACK SEDAN 1TB68
---------------------------------	---------------------------------

Lamps and Headlamp Shape*

Height above ground to center of bulb or marker	Headlamp (SAE - H127)	Highest**	667.0 (26.3)
		Lowest	--
	Taillamp (SAE - H128)	Highest**	695.0 (27.4)
		Lowest	--
	Sidemarker	Front	613.7 (24.2)
		Rear	695.0 (27.4)
Distance from C L of car to center of bulb	Headlamp	Inside	--
		Outside**	562.0 (22.1)
	Taillamp	Inside	--
		Outside**	621.5 (24.5)
	Directional	Front	520.0 (20.5)
		Rear	621.5 (24.5)
Halogen headlamp (std. opt. n.a.)	Lo beam	Not Available	
	Hi beam	" "	
	Replaceable bulb	" "	
	Shape	" "	
Headlamp other than above	Lo beam	Conventional	
	Hi beam	"	
	Replaceable	Sealed beam, entire unit replaced	
	Shape	Rectangular	
	Type	Two lamp system	

* Measured at curb mass (weight).
 ** If single lamps are used enter here.
 All linear dimensions are in millimeters (inches) unless otherwise noted.

MVMA Specifications Form
Passenger Car
METRIC (U.S. Customary)

Exterior Car And Body Dimensions – Key Sheet

Exterior Width

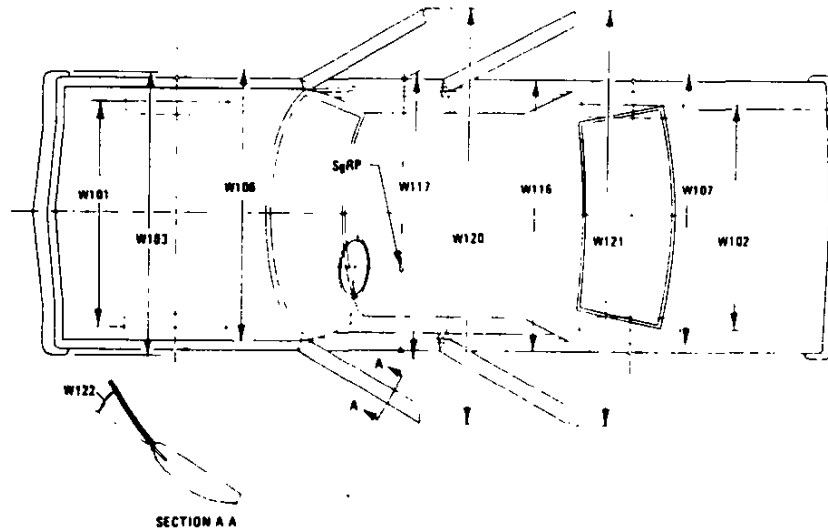

Exterior Length & Height

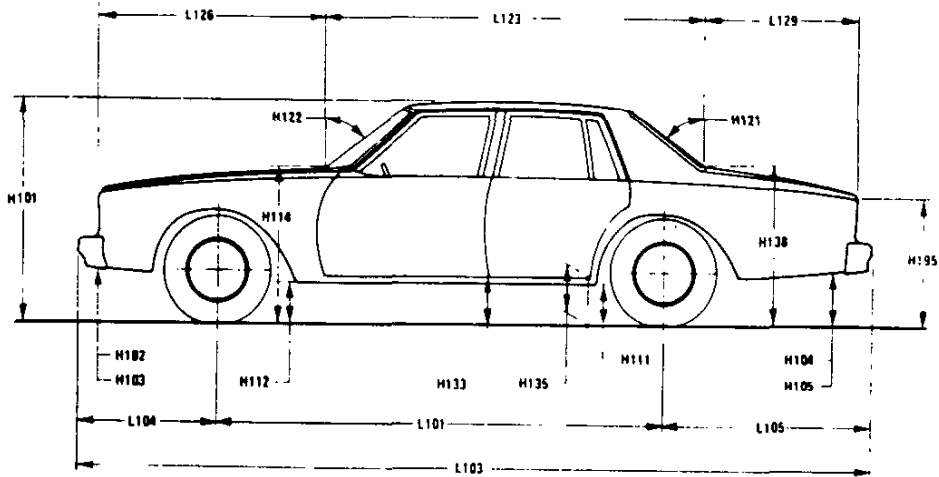

Exterior Ground Clearance

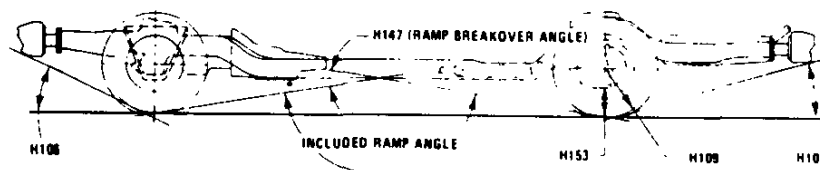

MVMA Specifications Form

Passenger Car

METRIC (U.S. Customary)

Interior Car And Body Dimensions – Key Sheet

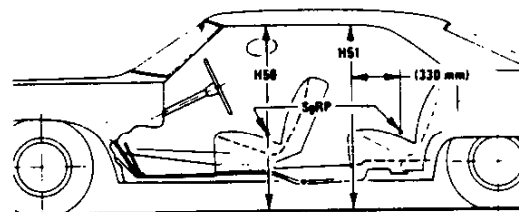
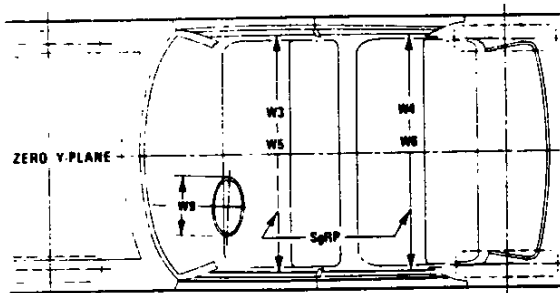
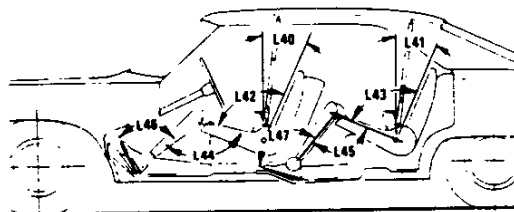
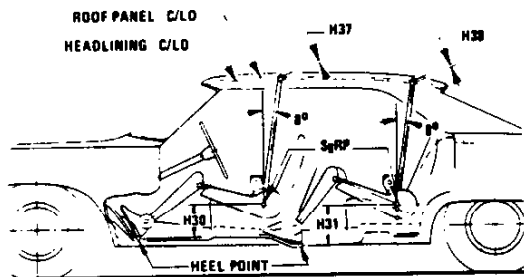
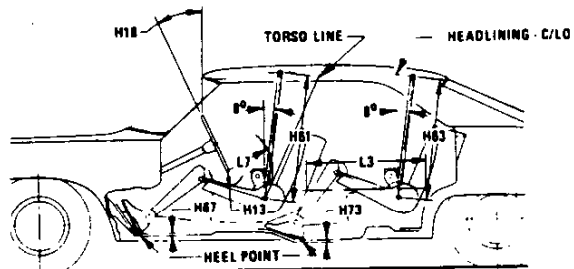
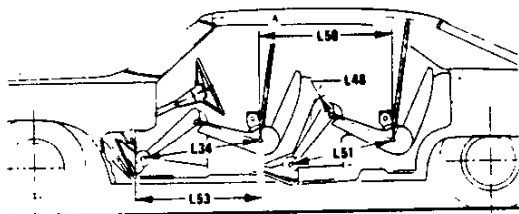

MVMA Specifications Form
Passenger Car
METRIC (U.S. Customary)

Interior Car And Body Dimensions – Key Sheet

Third Seat

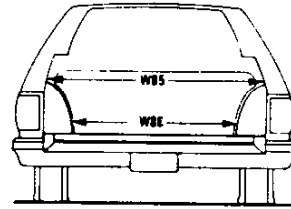
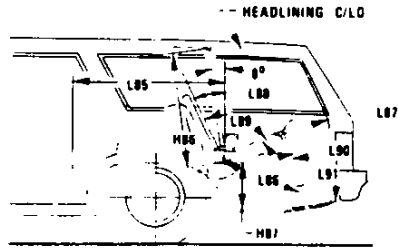

Cargo Space

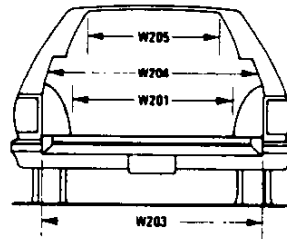
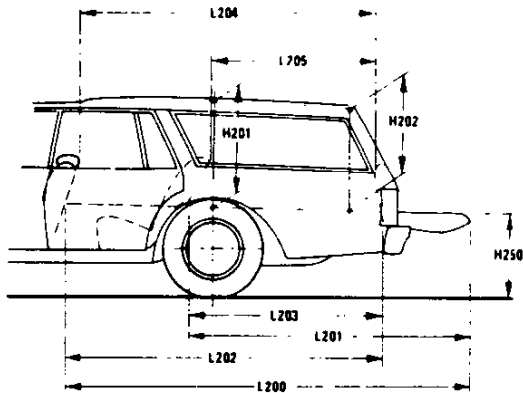

Station Wagon

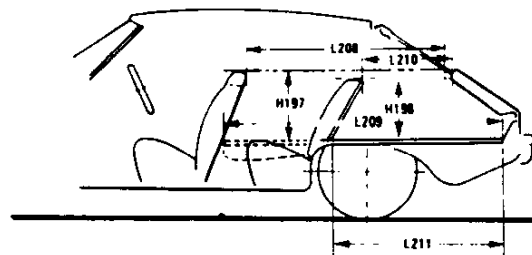

Hatchback

MVMA Specifications Form

Passenger Car

METRIC (U.S. Customary)

Exterior Car And Body Dimensions – Key Sheet

Dimensions Definitions

Seating Reference Point

SEATING REFERENCE POINT means the manufacturer's design reference point which –

- (a) Establishes the rearmost normal design driving or riding position of each designated seating position in a vehicle;
- (b) Has coordinates established relative to the design vehicle structure;
- (c) Simulates the position of the pivot center of the human torso and thigh; and
- (d) Is the reference point employed to position the two dimensional templates described in SAE Recommended Practice J826, "Devices for Use in Defining and Measuring Vehicle Seating Accommodations."

Width Dimensions

- W101 TREAD-FRONT. The dimension measured between the tire centerlines at the ground.
- W102 TREAD-REAR. The dimension measured between the tire centerlines at the ground. In case of dual wheels, the dimension will be measured to the centerline of tire and wheel assemblies.
- W103 VEHICLE WIDTH. The maximum dimension measured between the widest point on the vehicle, excluding exterior mirrors, flexible mud flaps, marker lamps, but including bumpers, moldings, sheet metal protrusions or dual wheels, if standard equipment.
- W106 FRONT FENDER WIDTH. The dimension measured between the widest points at the front wheel centerline, excluding moldings.
- W107 REAR FENDER WIDTH. The dimension measured between the widest points at the rear wheel centerline, excluding moldings.
- W117 BODY WIDTH AT SgRP-FRONT. The dimension measured laterally between the widest points on the body at the SgRP-front, excluding door handles, applied moldings, or appliques.
- W120 VEHICLE WIDTH-FRONT DOORS OPEN. The dimension measured between the widest point on the front doors in maximum hold-open position.
- W121 VEHICLE WIDTH-REAR DOORS OPEN. The dimension measured between the widest point on the rear doors in maximum hold-open position. For vehicles with a rear door on only one side, this dimension is to the zero "Y" plane.
- W122 TUMBLE-HOME STRAIGHT SIDE GLASS. The angle measured from a vertical to the outside surface of the front door glass at the SgRP "X" plane.
CURVED SIDE GLASS. The angle measured from a vertical to a chord extending from the upper DLO to the lower DLO at the outside surface of the front door glass at the front SgRP "X" plane.

Length Dimensions

- L101 WHEELBASE (WB). The dimension measured longitudinally between front and rear wheel centerlines. In case of dual rear axles, the dimension shall be to the midpoint of the centerlines of the rear wheels.
- L103 VEHICLE LENGTH. The maximum dimension measured longitudinally between the foremost point and the rearmost point on the vehicle, including bumper, bumper guards, tow hooks and/or rub strips, if standard equipment.
- L104 OVERHANG-FRONT. The dimension measured longitudinally from the centerline of the front wheels to the foremost point on the vehicle including bumper, bumper guards, tow hooks and/or rub strips, if standard equipment.
- L105 OVERHANG-REAR. The dimension measured longitudinally from the centerline of the rear wheels; or in the case

of dual rear axles, the dimension shall be the midpoint of the centerlines of the rear wheels, to the rearmost point on the vehicle including rear bumpers, bumper guards, tow hooks and rub strips, if standard equipment.

- L123 UPPER STRUCTURE LENGTH. The dimension measured longitudinally from the cowl point to the deck point.
- L125 COWL POINT "X" COORDINATE.
- L126 FRONT END LENGTH. The dimension measured longitudinally from the cowl point to the foremost point on the vehicle at the zero "Y" plane excluding ornamentation or bumpers. In cases where bumpers and/or grills are integrated with the profile, measurement is made at the foremost point of front end contour.
- L127 REAR WHEEL CENTERLINE "X" COORDINATE or in the case of dual rear axles, the coordinate shall be the midpoint of the distance between the rear axle centerlines.
- L129 REAR END LENGTH. The dimension measured longitudinally from the deck point to the rearmost visible point of the body sheet metal at the zero "Y" plane, excluding ornamentation or bumpers.

Height Dimensions

- H101 VEHICLE HEIGHT. The dimension measured vertically from the highest point on the vehicle body to ground.
- H111 ROCKER PANEL-REAR TO GROUND. The dimension measured vertically from the bottom of the rocker or side quarter panel at the front of the rear wheel opening, excluding flanges, to ground.
- H112 ROCKER PANEL-FRONT TO GROUND. The dimension measured vertically from the foremost point on the bottom of the rocker panels, excluding flanges, to ground.
- H114 COWL POINT TO GROUND. Measured at zero "Y" plane.
- H121 BACKLIGHT SLOPE ANGLE. The angle between the vertical reference line and the surface of backlight at vehicle zero "Y" plane. For curve backlight, the angle is to chord of backlight arc from lower DLO to upper DLO.
- H122 WINDSHIELD SLOPE ANGLE. The angle between the vertical reference line and a chord of the windshield arc running from the lower DLO to the upper DLO at the vehicle zero "Y" plane. In the case of wrap over glass, the angle to be measured will be formed by a chord 457 mm (18.0 in) long drawn from the lower DLO to the intersecting point on the windshield.
- H127 HEADLAMP TO GROUND-CURB MASS (WT.). The dimension measured vertically from the centerline of the lowest headlamp lens to ground.
- H128 TAILLAMP TO GROUND-CURB MASS (WT.). The dimension measured vertically from the centerline of the upper bulb to ground.
- H133 BOTTOM OF DOOR CLOSED-FRONT TO GROUND. The dimension measured vertically from the bottom outside corner of the door on the lock pillar side, in maximum closed position, to ground.
- H135 BOTTOM OF DOOR CLOSED-REAR TO GROUND. The dimension measured vertically from the bottom outside corner of the door on the lock pillar side, in maximum closed position, to ground.
- H138 DECK POINT TO GROUND. Measured at zero "Y" plane.
- H109 STATIC LOAD-TIRE RADIUS-REAR. Specified by the manufacturer in accordance with composite TIRE SECTION STANDARD.

Ground Clearance Dimensions

- H102 FRONT BUMPER TO GROUND. The minimum dimension measured vertically from the lowest point on the front bumper to ground, including bumper guards, if standard equipment.
- H103 FRONT BUMPER TO GROUND-CURB MASS (WT.). Measured in the same manner as H102.

MVMA Specifications Form

Passenger Car

METRIC (U.S. Customary)

Interior Car And Body Dimensions – Key Sheet

Dimensions Definitions

- H104 REAR BUMPER TO GROUND. The minimum dimension measured vertically from the lowest point on the rear bumper to ground, including bumper guards, if standard equipment.
- H105 REAR BUMPER TO GROUND – CURB MASS (WT.). Measured in the same manner as H104.
- H106 ANGLE OF APPROACH. The angle measured between a line tangent to the front tire static loaded radius arc and the initial point of structural interference forward of the front tire to ground. The limiting structural component shall be designated.
- H107 ANGLE OF DEPARTURE. The angle measured between a line tangent to the rear tire static loaded radius arc and the initial point of structural interference rearward of the rear tire to ground. The limiting component shall be designated.
- H147 RAMP BREAKOVER ANGLE. The angle measured between two lines tangent to the front and rear tire static loaded radius and intersecting at a point on the underside of the vehicle which defines the largest ramp over which the vehicle can roll.
- H153 REAR AXLE DIFFERENTIAL TO GROUND. The minimum dimension measured from the rear axle differential to ground.
- H156 MINIMUM RUNNING GROUND CLEARANCE. The minimum dimension measured from the sprung vehicle to ground. Specify location.

Glass Areas

- S1 Windshield area.
- S2 Side windows area. Includes the front door, rear door, vents, and rear quarter windows on both sides of the vehicle.
- S3 Backlight areas.
- S4 Total area. Total of all areas (S1 + S2 + S3).

Fiducial Mark Dimensions

Fiducial Mark – Number 1

- L54 "X" coordinate.
- W21 "Y" coordinate.
- H81 "Z" coordinate.
- H161 Height "Z" coordinate to ground at curb weight.
- H163 Height "Z" coordinate to ground.

Fiducial Mark – Number 2

- L55 "X" coordinate.
- W22 "Y" coordinate.
- W82 "Z" coordinate.
- H162 Height "Z" coordinate to ground at curb weight.
- H164 Height "Z" coordinate to ground.

Front Compartment Dimensions

- L7 STEERING WHEEL TORSO CLEARANCE. The minimum dimension measured in the side view from the rearmost edge of the steering wheel, with front wheels in the straight ahead position, to the torso line.
- L11 ACCELERATOR HEEL POINT TO STEERING WHEEL CENTER. The dimension measured horizontally from the AHP to the intersection of the steering column centerline and a plane tangent to the upper surface of the steering wheel rim.
- L17 DESIGN H-POINT–FRONT TRAVEL. The dimension measured horizontally between the design H-point–front in the foremost and rearmost seat track positions. (See SAE J1100)
- L23 NORMAL DRIVING AND RIDING SEAT TRACK LEVEL. The dimension measured horizontally between a point on the design H-point travel line from the SgRP to the displaced point on the design H-point travel line with the seat moved to the foremost seat position, but not to include seat track travel used for purposes other than normal driving and riding positions. (See SAE J1100)
- L31 SgRP–FRONT. "X" COORDINATED.

- L34 MAXIMUM EFFECTIVE LEG ROOM–ACCELERATOR. The dimension measured along a line from the ankle pivot center to the SgRP–front plus 254 mm (10.0 in) measured with right foot on the undepressed accelerator pedal. For vehicles with SgRP to heel (H30) greater than 18 in., the accelerator pedal may be depressed as specified by the manufacturer. If the accelerator is depressed, the manufacturer shall place foot flat on pedal and note the depression of the pedal.
- L40 BACK ANGLE–FRONT. The angle measured between a vertical line through the SgRP–front and the torso line. If the seatback is adjustable, use the normal driving and riding position specified by the manufacturer.
- L42 HIP ANGLE–FRONT. The angle measured between torso line and thigh centerline.
- L44 KNEE ANGLE–FRONT. The angle measured between thigh centerline and lower leg centerline measured on the right leg.
- L46 FOOT ANGLE–FRONT. The angle measured between the lower leg centerline and a line tangent to the ball and heel of the bare foot flesh line measured on the right leg. Ref SAE J826.
- L53 SgRP–FRONT TO HEEL. The dimension measured horizontally from the SgRP–front to the accelerator heel point.
- W3 SHOULDER ROOM–FRONT. The minimum dimension measured laterally between the trimmed surfaces on the "X" plane through the SgRP–front at height between the belt line and 254 mm (10.0 in.) above the SgRP–front, excluding the door assist strap and attaching parts.
- W5 HIP ROOM–FRONT. The minimum dimension measured laterally between the trimmed surfaces on the "X" plane through the SgRP–front within 25 mm (1.0 in.) below and 76 mm (3.0 in.) above the SgRP–front and 76 mm (3.0 in.) fore and aft of the SgRP–front.
- W9 STEERING WHEEL MAXIMUM OUTSIDE DIAMETER. Define if other than round.
- H13 STEERING WHEEL TO CENTERLINE OF THIGH. The minimum dimension measured from the bottom of steering wheel, with front wheels in the straight position, to the thigh centerline.
- H17 ACCELERATOR HEEL POINT TO THE STEERING WHEEL CENTER. The dimension measured vertically from the AHP–front to the intersection of the steering column centerline to a plane tangent to the upper surface of the steering wheel rim.
- H18 STEERING WHEEL ANGLE. The angle measured from a vertical to the surface plane of the steering wheel.
- H30 SgRP–FRONT TO HEEL. The dimension measured vertically from the SgRP–front to the accelerator heel point.
- H37 HEADLINING TO ROOF PANEL–FRONT. The dimension measured from the intersection of the headlining and the extended effective head room line normal to the sheet metal.
- H50 UPPER BODY OPENING TO GROUND–FRONT. The dimension measured vertically from the trimmed body opening to the ground on the SgRP–front "X" plane.
- H61 EFFECTIVE HEAD ROOM–FRONT. The dimension measured along a line 8 deg. rear of vertical from the SgRP–front to the headlining plus 102 mm (4.0 in.).
- H67 FLOOR COVERING THICKNESS–UNDEPRESSED–FRONT. The dimension measured vertically from the surface of the undepressed floor covering to the underbody sheet metal at the accelerator heel point.
- PD1 PASSENGER DISTRIBUTION–FRONT

Rear Compartment Dimensions

- L3 COMPARTMENT ROOM–SECOND. The dimension measured horizontally from the back of front seat to the front of the second seatback at a height tangent to the top of the second seat cushion.

MVMA Specifications Form

Passenger Car

METRIC (U.S. Customary)

Interior Car And Body Dimensions – Key Sheet

Dimensions Definitions

- L41 BACK ANGLE-SECOND. The angle measured between a vertical line through the SgRP-second and the torso line.
- L43 HIP ANGLE-SECOND. The angle measured between torso line and thigh centerline.
- L45 KNEE ANGLE-SECOND. The angle measured between thigh centerline and lower leg centerline.
- L47 FOOT ANGLE-SECOND. The angle measured between the lower leg centerline and a line tangent to the ball and heel of the three-dimensional devices bare foot flesh line (Reference J826).
- L48 KNEE CLEARANCE-SECOND. The minimum dimension measured from the knee pivot center to the back of the front seatback minus 51 mm (2.0 in.).
- L50 SgRP COUPLE DISTANCE-SECOND. The dimension measured horizontally from the driver SgRP-front to the SgRP-second.
- L51 MINIMUM EFFECTIVE LEG ROOM-SECOND. The dimension measured along a line from the ankle pivot center to the SgRP-second plus 254mm (10.0 in.).
- W4 SHOULDER ROOM-SECOND. The minimum dimension measured laterally between door or quarter trimmed surfaces on the "X" plane through the SgRP-second at height between 254-406 mm (10.0-16.0 in.) above the SgRP-second, excluding the door assist straps and attaching parts.
- W6 HIP ROOM-SECOND. Measured in the same manner as W5.
- H31 SgRP-SECOND TO HEEL. The dimension measured vertically from the SgRP-second to the two dimensional device heel point on the depressed floor covering.
- H38 HEADLINING TO ROOF PANEL-SECOND. The dimension measured from the intersection of the headlining and the extended effective head room line normally to the roof sheet metal.
- H51 UPPER BODY OPENING TO GROUND-SECOND. The dimension measured vertically from the trimmed body opening to the ground on the "X" plane 330 mm (13.0 in.) forward of the SgRP-second.
- H63 EFFECTIVE HEAD ROOM-SECOND. The dimension measured along a line 8 deg. rear of vertical from the SgRP to the headlining, plus 102 mm (4.0 in.).
- H73 FLOOR COVERING-DEPRESSED-SECOND. The dimension measured vertically from the heel point to the underbody sheet metal.
- PD2 PASSENGER DISTRIBUTION-SECOND.

Luggage Compartment Dimensions

- V1 USABLE LUGGAGE CAPACITY-Total of volumes of individual pieces of standard luggage set plus H-boxes stowed in the luggage compartment in accordance with the procedure described in paragraph 8.2 of SAE-J1100a.
- H195 LIFTOVER HEIGHT. The dimension measured vertically from the luggage compartment lower opening at the zero "Y" plane to ground.

Interior Volumes (EPA Classification)

The Interior Volume Index is listed for each body style except two seaters. The interior volume index estimates the space in a car. It is based on four measurements – head room, shoulder room, hip room, and leg room – for the front and rear seats, plus trunk capacity. The interior volume index is an estimate of the size of the passenger compartment.

The Trunk Cargo Index is an estimate of the size of the trunk cargo space. In station wagons and hatchbacks it is an estimate of the space behind the second seat.

Station Wagon – Third Seat Dimensions

- L85 SgRP COUPLE DISTANCE-THIRD. The dimension measured horizontally from the SgRP-second to the SgRP-third.
- L86 EFFECTIVE LEG ROOM-THIRD. The dimension measured along a line from the ankle pivot center to the SgRP-third plus 254 mm (10.0 in.).
- L87 KNEE CLEARANCE-THIRD. The minimum dimension from the knee pivot center to the back of second seatback minus a constant of 51mm (2.0 in.). With rear-facing third seat, dimension is measured to closure.
- L88 BACK ANGLE-THIRD. Measured in the same manner as L41.
- L89 HIP ANGLE-THIRD. Measured in the same manner as L43.
- L90 KNEE ANGLE-THIRD. Measured in the same manner as L45.
- L91 FOOT ANGLE-THIRD. Measured in the same manner as L47.
- W85 SHOULDER ROOM-THIRD. Measured in the same manner as W4.
- W86 HIP ROOM-THIRD. Measured in the same manner as W5.
- H86 EFFECTIVE HEAD ROOM-THIRD. The dimension, measured along a line 8 deg. from the SgRP-third to the headlining rear of vertical plus a constant of 102 mm (4.0 in.) SgRP-THIRD TO HEEL POINT.
- H87 PASSENGER DIRECTION-THIRD.
- PD3 SEAT FACING DIRECTION-THIRD.
- SD1

Station Wagon – Cargo Space Dimensions

- L200 CARGO LENGTH-OPEN-FRONT. The minimum dimension measured longitudinally from the back of the front seatback at the height of the undepressed floor covering to the rearmost point on the undepressed floor covering on the open tailgate or cargo surface if the rear closure is a conventional door type tailgate at the zero "Y" plane.
- L201 CARGO LENGTH-OPEN-SECOND. The dimension measured longitudinally from the back of the second seatback at the height of the undepressed floor covering to the rearmost point on the undepressed floor covering on the open tailgate or cargo floor surface if the rear closure is a conventional door type tailgate, at the zero "Y" plane.
- L202 CARGO LENGTH-CLOSED-FRONT. The minimum dimension measured horizontally from the back of the front seat at the height of the undepressed floor covering to the rearmost point on the undepressed floor covering on the closed tailgate or taildoor for station wagons, trucks and mpv's at the zero "Y" plane.
- L203 CARGO LENGTH-CLOSED-SECOND. The dimension measured horizontally from the back of the second seat at the height of the undepressed floor covering to the rearmost point on the undepressed floor covering on the closed tailgate or taildoor for station wagons, trucks and mpv's at the zero "Y" plane.
- L204 CARGO LENGTH AT BELT-FRONT. The minimum dimension measured horizontally from the back of the front seatback at the seatback top to the foremost normal surface of the closed tailgate or inside surface of the cab backpanel at the height of the belt, on the zero "Y" plane.
- L205 CARGO LENGTH AT BELT-SECOND. The minimum dimension measured horizontally from the back of the second seatback at the seatback top to the foremost normal surface of the closed tailgate at the height of the belt on the zero "Y" plane.
- W201 CARGO WIDTH-WHEELHOUSE. The minimum dimension measured laterally between the trimmed wheelhouse sills at floor level. For any vehicle not trimmed, measure to the sheet metal.

MVMA Specifications Form Passenger Car

METRIC (U.S. Customary)

Interior Car And Body Dimensions – Key Sheet Dimensions Definitions

- W203 REAR OPENING WIDTH AT FLOOR. The minimum dimension measured laterally between the limiting interferences of the rear opening at floor level.
- W204 REAR OPENING WIDTH AT BELT. The minimum dimension measured laterally between the limiting interferences of the rear opening at belt height or top of pick up box.
- W205 REAR OPENING WIDTH ABOVE BELT. The minimum dimension measured laterally between the limiting interferences of the rear opening above the belt height.
- H197 FRONT SEATBACK TO LOAD FLOOR HEIGHT. The dimension measured vertically from the horizontal tangent to the top of the seatback to the undepressed floor covering.
- H201 CARGO HEIGHT. The dimension measured vertically from the top of the undepressed floor covering to the headlining at the rear wheel "X" coordinate on the zero "Y" plane.
- H202 REAR OPENING HEIGHT. The dimension measured vertically from the top of the undepressed floor covering to the upper trimmed opening on the zero "Y" plane with rear door fully open.
- H250 TAILGATE TO GROUND CURB MASS (WT.). The dimension measured vertically from the top of the undepressed floor covering on the lowered tailgate to ground on the zero "Y" plane.
- V2 STATION WAGON
Measured in inches:
$$\frac{W4 \times H201 \times L204}{1728} = \text{ft}^3$$

Measured in mm:
$$\frac{W4 \times H201 \times L204}{10^9} = \text{m}^3 \text{ (cubic meter)}$$
- V4 HIDDEN LUGGAGE CAPACITY-REAR OF FRONT SEAT. The total volumes of individual pieces of one set of standard luggage stowed in any hidden cargo area below the load floor rear of the front seat.
- V5 TRUCKS AND MPV'S WITH OPEN AREA.
Measured in inches:
$$\frac{L506 \times W500 \times H503}{1728} = \text{ft}^3$$

Measured in mm:
$$\frac{L506 \times W500 \times H503}{10^9} = \text{m}^3 \text{ (cubic meter)}$$
- V6 TRUCKS AND MPV'S WITH CLOSED AREA.
Measured in inches:
$$\frac{L204 \times W500 \times H505}{1728} = \text{ft}^3$$

Measured in mm:
$$\frac{L204 \times W500 \times H505}{10^9} = \text{m}^3 \text{ (cubic meter)}$$
- V8 HIDDEN LUGGAGE CAPACITY-REAR OF SECOND SEAT. The total volume of individual pieces of one set of standard luggage stowed in any hidden cargo area below the load floor rear of the second seat.
- V10 STATION WAGON CARGO VOLUME INDEX.
Measured in inches:
$$\frac{H201 \times L205 \times \frac{W4 + W201}{2}}{1728} = \text{ft}^3$$

Measured in mm:
$$\frac{H201 \times L205 \times \frac{W4 + W201}{2}}{10^9} = \text{m}^3 \text{ (cubic meter)}$$

Hatchback – Cargo Space Dimensions

All hatchback cargo dimensions are to be taken with the front seat in full down and rear position, and the rear seat folded down. The hatchback door is in the closed position. (For electrically adjusted seats, see the manufacturer's specifications for Design "H" Point).

- L208 CARGO LENGTH AT FRONT SEATBACK HEIGHT. The minimum horizontal dimension from the "X" plane tangent to the rearmost surface of the driver's seatback to the inside limiting interference of the hatchback door on the vehicle zero "Y" plane.
- L209 CARGO LENGTH AT FLOOR-FRONT-HATCHBACK. The minimum horizontal dimension measured at floor level from the rear of the front seatback to the normal limiting interference of the hatchback door on the vehicle zero "Y" plane.
- L210 CARGO LENGTH AT SECOND SEATBACK HEIGHT-HATCHBACK. The minimum dimension measured from the "X" plane tangent to the rearmost surface of second seatback or the load floor which is stowed at least one half of the H198 dimension height above the rear load floor, to the rearmost inside limiting interference on the zero "Y" plane.
- L211 CARGO LENGTH AT FLOOR-SECOND HATCHBACK. The minimum horizontal dimension measured at floor level from the rear of the second seatback or load floor panel to the normal limiting interference of the hatchback door on the vehicle zero "Y" plane.
- H197 FRONT SEATBACK TO LOAD HEIGHT. The dimension measured vertically from the horizontal tangent to the top of the seatback to the undepressed floor covering.
- H198 SECOND SEATBACK TO LOAD FLOOR HEIGHT. The dimension measured vertically from the second seat back to the undepressed floor covering.
- V3 HATCHBACK.
Measured in inches:
$$\frac{L208 + L209}{2} \times W4 \times H197 = \text{ft}^3$$

Measured in mm:
$$\frac{L208 + L209}{2} \times W4 \times H197 = \text{m}^3 \text{ (cubic meter)}$$
- V4 HIDDEN LUGGAGE CAPACITY-REAR OF FRONT SEAT. The total volumes of individual pieces of one set of standard luggage stowed in any hidden cargo area below the load floor rear of the front seat.
- V11 HATCHBACK CARGO VOLUME INDEX. Usable luggage (one (1) stand and luggage set) below floor:
Measured in inches:
$$\frac{L210 + L211}{2} \times W4 \times H198 = \text{ft}^3$$

Measured in mm:
$$\frac{L210 + L211}{2} \times W4 \times H198 = \text{m}^3 \text{ (cubic meter)}$$

MVMA Specifications Form

Passenger Car

METRIC (U.S. Customary)

Index

Subject	Page No.	Subject	Page No.
Aerodynamics	22	Lamps and Headlamp Shape	24
Alternator	16	Legroom	21, 22
Automatic Transmission/Transaxle	8, 9	Lengths - Car and Body	20
Axis, Steering	14	Leveling, Suspension	11
Axle, Drive, Front, Rear	2, 9, 10	Lifters, Valve	4
Axle Shafts	10	Linings - Clutch, Brake	8, 12
Battery	16	Lubrication - Engine Transmission/Transaxle	4, 8, 9
Body and Miscellaneous Information	17	Luggage Compartment	21
Brakes - Parking, Service	12, 13	Mass	25, 26
Camber	15	Models	1
Camshaft	3	Motor Starting	16
Capacities		Muffler	7
Cooling System	5	Passenger Capacity	1
Fuel Tank	6	Passenger Mass Distribution	25
Lubricants		Pistons	3
Engine Crankcase	4	Power Brakes	12
Transmission/Transaxle	8, 9	Power, Engine	2
Rear Axle	10	Power Steering	14
Car Models	1	Power Teams	2
Car and Body Dimensions		Propeller Shaft, Universal Joints	10
Width	20	Pumps - Fuel	6
Length	20	Water	5
Height	20	Radiator - Cap, Hoses, Core	5
Ground Clearance	20	Ratios - Axle, Transaxle	2, 9
Front Compartment	21	Compression	2
Rear Compartment	21	Steering	14
Luggage Compartment	21	Transmission/Transaxle	2, 8, 9
Station Wagon - Third Seat	22	Rear Axle	2, 9, 10
Station Wagon - Cargo Space	22	Regulator - Alternator	16
Hatchback - Cargo Space	22	Restraint System	18
Carburetor	2, 6	Rims	13
Caster	15	Rods - Connecting	4
Choke, Automatic	6	Scrub Radius	14
Clutch - Pedal Operated	8	Seats	17
Coil, Ignition	16	Shock Absorbers, Front & Rear	11
Connecting Rods	4	Spark Plugs	16
Convenience Equipment	19	Speedometer	15
Cooling System	5	Springs - Front & Rear Suspension	11
Crankshaft	4	Stabilizer (Sway Bar) - Front & Rear	11
Cylinders and Cylinder Head	3	Starting System	16
Diesel Information	4	Steering	14
Dimension Definitions		Suppression - Ignition, Radio	16
Key Sheet - Exterior	27, 30, 31	Suspension - Front & Rear	11
Key Sheet - Interior	28, 29, 31, 32, 33	Tail Pipe	7
Electrical System	15, 16	Theft Protection	19
Emission Controls	7	Thermostat, Cooling	5
Engine - General		Tires	13
Bore, Stroke, Type	3	Toe-In	15
Compression Ratio	2	Torque Converter	9
Displacement	2, 3	Torque - Engine	2, 8, 9
Firing Order, Cylinder Numbering	3	Transaxle	9
General Information, Power & Torque	2	Transmission - Types	2, 8, 9
Intake System	4	Transmission - Automatic	2, 8, 9
Power Teams	2	Transmission - Manual	2, 8, 9
Exhaust System	7	Transmission - Ratios	2, 9
Equipment Availability, Convenience	19	Tread	20
Fan, Cooling	5	Trunk Cargo Load	1
Fiducial Marks	23	Trunk Luggage Capacity	21
Filters - Engine Oil, Fuel System	4	Turning Diameter	14
Frame	17	Unitized Construction	17
Front Suspension	11	Universal Joints, Propeller Shaft	10
Front Wheel Drive Unit	10	Valve System	4
Fuel System	6	Voltage Regulator	16
Fuel Injection	6	Water Pump	5
Fuel Tank	6	Weights	25, 26
Glass	18	Wheel Alignment	15
Headroom - Body	21, 22	Wheelbase	20
Heights - Car and Body	20	Wheels & Tires	13
Horns	15	Wheel Spindle	14
Horsepower - Brake	2	Widths - Car and Body	20
Ignition System	16	Windshield	18
Inflation - Tires	13	Windshield Wiper and Washer	15
Interior Volumes	21		
Instruments	15		

**MVMA Specifications Form
Passenger Car**

Car Line _____
Model Year _____ Issued _____ Revised (●) _____

**METRIC (U.S. Customary)
SUPPLEMENTAL PAGE**



1
2
3

