



TORRANCE, CA 90503 #PV119E

MOTOR VEHICLE

Specifications

METRIC (U.S. Customary)

Passenger Car

1985

Manufacturer Chevrolet Motor Division General Motors Corporation	Car Line Citation II
Mailing Address Chevrolet Engineering Center 30003 Van Dyke Warren, MI 48090-9060	Issued July, 1984
	Revised October 1984

Questions concerning these specifications should be directed to the manufacturer whose address is shown above.

The information contained herein is prepared, distributed by, and is solely the responsibility of the automobile manufacturing company to whose products it relates. This specification form was developed by the automobile manufacturing companies under the auspices of the Motor Vehicle Manufacturers Association of the United States, Inc.

The General Specifications herein are those in effect at date of compilation and are subject to change without notice by the manufacturer.

MVMA Specifications Form Passenger Car

METRIC (U.S. Customary)

Table of Contents

1	Car Models
2	Power Teams
3-6	Engine
4	Lubrication System
4	Diesel Information
5	Cooling System
6	Fuel System
7	Vehicle Emission Control
7	Exhaust System
8-10	Transmission, Axles and Shafts
11	Suspension-Front and Rear
12-13	Brakes
13	Tires and Wheels
14-15	Steering
15-16	Electrical
17	Body – Miscellaneous Information
17	Glass
17	Frame
18	Restraint System
19	Convenience Equipment
20-22	Car and Body Dimensions
23	Vehicle Fiducial Marks
24	Lamps and Headlamps
25	Vehicle Mass (Weight)
26	Optional Equipment Differential Mass (Weight)
27-31	Car and Body Dimension Key Sheets
32	Index

NOTE:

1. This form uses both SI metric units and U.S. Customary units. The metric unit of measure is presented first, and the U.S. Customary unit follows in parentheses.
2. UNLESS OTHERWISE INDICATED:
 - a. Specifications apply to standard models without optional equipment. Significant deviations are noted.
 - b. Nominal design dimensions are used throughout these specifications.
 - c. All linear dimensions are in millimeters (inches), and all mass (weight) specifications are in kilograms (pounds).
3. The General Specifications herein are those in effect at date of completion and are subject to change without notice by the manufacturer.
4. Additional Car and Body Dimensions and/or drawings (based in part on SAE J1100a "Motor Vehicle Dimensions") may be available from the manufacturer.

Car Models

Model Description FWD/RWD	Introduction Date	Make, Car Line, Series, Body Type (Mfr's Model Code)	No. of Designated Seating Positions (Front/Rear)	Max. Trunk/Cargo Load—Kilograms (Pounds)
FRONT WHEEL DRIVE				
CITATION II		MODEL NUMBER	FRONT/REAR	
2-Door Hatchback Coupe		1XX08	2 3	56.9 (125.4)
4-Door Hatchback Sedan		1XX68	2 3	56.9 (125.4)

Note: Any specifications on the following pages that are specific to California requirements are indicated accordingly.

Insurance, CA 95053 # PV11111111

MVMA Specifications Form Passenger Car

Car Line CITATION II
 Model Year 1985 Issued 7-84 Revised (●) _____

METRIC (U.S. Customary)

Power Teams (Indicate whether standard or optional)
 SAE J1349 Net bhp (brake horsepower) and net torque corrected to 77°F/25° C and 29.91 in. Hg 100 kPa atmospheric pressure.

SERIES AVAILABILITY	ENGINE					E x h a u s t S/D	TRANSMISSION TRANSAXLE	DRIVE RATIOS (:1)			
	Displ. Liters (in ³)	Carb. (Barrels, Fl. etc.)	Compr. Ratio	SAE Net at RPM				AXLE RATIO		Overall Veh. Drive	Overall Veh. Drive
				kW (bhp)	Torque (lb.-m ft.)			Base Veh.	Opt.		
Base - All States	L-4 2.5L (151 CID) LR8	EFI *	9.0:1	92	134	S	Man. 4-speed (3.53 Low) - Base	3.32	3.42	--	--
				@ 4400	@ 2800		Auto '125c' Avail.	2.39	2.39	--	--
Avail - All States +	V6 2.8L (173 CID) LE2	2-8bbl Carb.	8.5:1	112	145	S	Man. 4-speed (3.53 Low) - Base	3.32	2.69	--	--
				@ 4800	@ 2100		Auto '125c' - Avail.	2.53	2.53	--	--
Avail - All States	V6 2.8L (173 CID) LB6	MFI **	8.9:1	130	155	S @@	Man. 4-speed (3.31 Low) - Base @	3.65	3.28	--	--
				@ 4800	@ 3600		Auto '125c' - Avail.	2.84	2.84	3.18%	3.18%
* - Electronic Fuel Injection ** - 2.8 Multi-Port FI @@ - With dual tailpipes % - Available on X-11 only + - Not available in California @ - Requires F41 Suspension											

Passenger Car
METRIC (U.S. Customary)

Engine Description/Carb.
 Engine Code

2.5 LTR. L4 (151 CID) ELECTRONIC FUEL INJ. RPO LR8	2.8 LTR. V6 (173 CID) 2-BBL. CARBURETOR RPO LE2	2.8 LTR. V6 H. 2.8 MULTI-POR? RPO LB6
----------------------------------------------------------	-------------------------------------------------------	---------------------------------------------

ENGINE - GENERAL

Type & description (inline, V, angle, flat, location, front, mid, rear, transverse, longitudinal, sohc, dohc, ohv, hemi, wedge, pre-camber, etc.)	In Line Front	60° V	
	Transverse, front of engine faces right side of vehicle		
No. of cylinders	4	6	
Bore	101.6 (4.0)	89 (3.50)	
Stroke	76.2 (3.0)	76 (2.99)	
Bore spacing (c/l to c/l)	111.8 (4.40)		
Cylinder block material	Cast alloy iron		
Cylinder block deck height	236.1 (9.3)	224 (8.819)	
Deck clearance (minimum) (above or below block)	0.64 (.025) Below	0.62 (.024) Below	0.12 (.005) Be
Cylinder head material	Cast alloy iron		
Cylinder head volume (cm ³)	45.62 (2.78)	--	
Head gasket thickness (compressed)	0.97 (0.38)	0.838 (0.033)	
Minimum combustion chamber total volume (cm ³)	70.82 (4.32)	63.41734 (3.86927) @	59.8481 (3.6515)
Cyl. no system (front to rear)*	L. Bank	1-2-3-4	2-4-6
	R. Bank	--	1-3-5
Firing order	1-3-4-2	1-2-3-4-5-6	
Recommended fuel (leaded, unleaded, diesel)	Unleaded		
Fuel antiknock index $\frac{(R + M)}{2}$	87		
Total dressed engine mass (wt) dry**	146.0 (321.9) Auto.	175.9 (387.8) Auto.	185.5 (408.9)
Engine - Pistons	156.7 (345.5) Man.	166.9 (367.9) Man.	
Material & mass, g (weight, oz) - piston only	Cast Aluminum Alloy		
	.650 (22.93)	.467 (16.47), Flat Head	.467 (16.47)
Engine - Camshaft			
Location	Right side of block	In block above crankshaft	
Material & mass kg (weight, lbs.)	Cast Nodular Iron		
	3.490 (7.698)	3.098 (6.83)	3.098 (6.83)
Drive type	Chain / belt	Gear	
	Width / pitch	19.4 (.764) / 9.53 (.375)	

* Rear of engine - drive takeoff. View from drive takeoff end to determine left & right side of engine.
 ** Dressed engine mass (weight) includes the following:

All those items necessary to make the engine a complete ready-to-run unit.

@ - Piston at TDC, spark plug and valves in place, and cylinder head torqued to specifications.

Torrance, CA 90503 # PVT/ME

MVMA Specifications Form Passenger Car

Car Line CITATION II
 Model Year 1985 Issued 7-84 Revised (•) 9-84

METRIC (U.S. Customary)

Engine Description/Carb.
Engine Code

2.5 LITER L4 (151 CID) ELECTRONIC FUEL INJ. RPO LR8	2.8 LITER V6 (173 CID) 2-88L. CARBURETOR RPO LE2	2.8 MULTI-PORT FI RPO LB6
-----------------------------------------------------------	--------------------------------------------------------	------------------------------

Engine - Valve System

Hydraulic lifters (std., opt., NA)	Standard		
Valves	Number intake / exhaust	4/4	6/6
	Head O.D. intake / exhaust	43.69(1.72)/38.10 (1.50)	40.64(1.60)/33.20(1.31) 43.64(1.72)/36.20(1.43)

Engine - Connecting Rods

Material & mass (kg., (weight, lbs.))	Cast Arma steel .621 (1.37)	.399 (0.880) 1038 steel
---------------------------------------	-----------------------------	-------------------------

Engine - Crankshaft

Material & mass (kg., (weight, lbs.))	Nodular cast iron/12.510(27.52)	Nodular cast iron/14.170(31.24)
End thrust taken by bearing (no.)	5	3
Number of main bearings	5	4

Engine - Lubrication System

Normal oil pressure (kPa (psi) at engine rpm)	259 (37.5)	345-450 (50-65) @ 1200
Type oil intake (floating, stationary)	Stationary	
Oil filter system (full flow, part, other)	Full flow	
Capacity of cr.cafe. less filter-refill-L (qt.)	2.8 (3.0)	3.8 (4.0)

Engine - Diesel Information

Diesel engine manufacturer	
Glow plug, current drain at 0°F	Not
Injector nozzle	Type
	Opening pressure (kPa (psi))
Pre-chamber design	
Fuel in-jection pump	Manufacturer
	Type
Fuel injection pump drive (belt, chain, gear)	
Supplementary vacuum source (type)	
Fuel heater (yes/no)	
Water separator, description (std., opt.)	
Turbo manufacturer	
Oil cooler-type (oil to engine coolant; oil to ambient air)	
Oil filter	

Engine - Intake System

Turbo charger - manufacturer	Not
Super charger - manufacturer	Applicable
Charge cooler	

MVMA Specifications Form
Passenger Car

Model Year 1985 issued 7-84 Revised (e)

METRIC (U.S. Customary)

Engine Description/Code
 Engine Code

2.5 LITER L4 (151 CID)
 ELECTRONIC FUEL INJ.
 RPO LR8

Engine - Cooling System

Coolant recovery system (std., opt., n.a.)		Standard					
Coolant fill location (rad., bottle)		Bottle, Coolant Recovery					
Radiator cap relief valve pressure [kPa (psi)]		103.4 (15.0)					
Circulation thermostat	Type (choke, bypass)	Choke					
	Starts to open at °C (°F)	90 (195°)					
Water pump	Type (centrifugal, other)	Centrifugal					
	GPM 1000 pump rpm	6					
	Number of pumps	One					
	Drive (V-belt, other)	V-Belt					
Bearing type		Ball-Roller					
By-pass recirculation (type (inter., ext.))		External					
Cooling system capacity	With heater—L(qt.)	8.24 (8.71) Automatic, 8.34 (8.82) Manual					
	With air cond.—L(qt.)	8.53 (9.02) Automatic, 8.63 (9.12) Manual					
	Opt. equipment (specify—L(qt.))	8.59 (9.08) Manual Heavy Duty					
Water jackets full length of cyl. (yes, no)		Yes					
Water all around cylinder (yes, no)		Yes					
Radiator core	Describe (type, material, no. of rows)	Cross-flow, copper-brass, high efficiency radiator					
	Std., A/C, HD Manual/Auto	Std.	A/C	H.D.	Std.	A/C	H.D.
	Width	430.0	600.0	600.0	430.0	600.0	600.0
	Height	303.2	303.2	387.5	303.2	303.2	387.5
	Thickness	25.0	25.0	40.2	25.0	25.0	40.2
	Fins per inch @	3.5	3.0	3.5	4.0	3.5	3.5
Fan	Std., elec., opt.	Std. Elec.		A/C Elec.			
	Number of blades & type (flex, solid, material)	4, Plastic, solid		7, Plastic, solid			
	Diameter & projected width	291		360			
	Ratio (fan to crankshaft rev.)	Not Applicable					
	Fan cutout type	ECM					
	Drive (type (direct, remote))	Direct					
	RPM at idle (elec.)	1900		2700			
	Motor rating (wattage) (elec.)	97		150			
	Motor switch (type & location) (elec.)	Engine temperature switch, engine cylinder head					
	Switch point (temp., pressure) (elec.)	110°C					
Fan shroud (material)	None						

@ - Distance between top of fins.

MVMA Specifications Form Passenger Car

Car Line CITATION II
 Model Year 1985 Issued 7-84 Revised (●) _____

METRIC (U.S. Customary)

Engine Description/Carb.
 Engine Code

2.8 LITER V6 (173 CID)
 2-BBL CARBURETOR
 RPO LE2

Engine - Cooling System

Coolant recovery system (std., opt., n.a.)	Standard						
Coolant fill location (rad., bottle)	Bottle, Coolant Recovery						
Radiator cap relief valve pressure (kPa (psi))	103.4 (15.0)						
Circulation thermostat	Type (choke, bypass)	Choke					
	Starts to open at °C (°F)	90 (195°)					
Water pump	Type (centrifugal, other)	Centrifugal					
	GPM 1000 pump rpm	22.7 @ 3000 pump RPM					
	Number of pumps	One					
	Drive (V-belt, other)	V-Belt					
	Bearing type	Ball-Roller					
By-pass recirculation [type (inter., ext.)]	Internal						
Cooling system capacity	With heater—L/qt.)	10.04 (10.61) Automatic, 10.14 (10.72) Manual					
	With air cond.—L/qt.)	10.39 (10.98) Automatic, 10.49 (11.09) Manual					
	Opt. equipment [specify—L/qt.)]	10.55 (11.15) Automatic & Manual, H.D. Radiator					
Water jackets full length of cyl. (yes, no)	Yes						
Water all around cylinder (yes, no)	Yes						
Radiator core	Describe (type, material, no. of rows)	Cross-flow, copper-brass, high efficiency radiator					
	Std., A/C, HD	Auto.Std.	Auto.A/C	Auto.H.D.	Man.Std.	Man.A/C	Man.H.D.
	Width	430.0	600.0	600.0	430.0	600.0	600.0
	Height	303.2	303.2	387.5	303.2	387.5	387.5
	Thickness	25.0	25.0	40.2	25.0	25.0	40.2
	Fins per inch	4.0*	4.0*	3.5*	3.0*	3.5*	3.5*
	Std., elec., opt.	Std. Elec.		A/C Elec.			
Fan	Number of blades & type (flex. solid, material)	4, Plastic, Solid		7, Plastic, Solid			
	Diameter & projected width	291.0		360.0			
	Ratio (fan to crankshaft rev.)	Not Applicable					
	Fan cutout type	ECM Controlled					
	Drive [type (direct, remote)]	Direct					
	RPM at idle (elec.)	1900		2700			
	Motor rating (wattage) (elec.)	97		150			
	Motor switch (type & location) (elec.)	Engine temperature switch, engine cylinder head					
	Switch point (temp., pressure) (elec.)	110.5°C					
Fan shroud (material)	None						

* - Distance between top of fins.

METRIC (U.S. Customary)

Engine Description/Carb.
Engine Code

2.8 LITER V6 (173 CID)
2.8 MULTI-PORT FI
RPO LB6

Engine - Cooling System

Coolant recovery system (std., opt., n.a.)		Standard			
Coolant fill location (rad., bottle)		Bottle, Coolant Recovery			
Radiator cap relief valve pressure (kPa (psi))		103.4 (15.0)			
Circulation thermostat	Type (choke, bypass)	Choke			
	Starts to open at °C (°F)	90 (195°)			
Water pump	Type (centrifugal, other)	Centrifugal			
	GPM 1000 pump rpm	22.7 @ 3000 pump RPM			
	Number of pumps	One			
	Drive (V-belt, other)	V-Belt			
Bearing type		Ball-Roller			
By-pass recirculation [type (inter., ext.)]		Internal			
Cooling system capacity	With heater—L.(qt.)	10.04 (10.61) Automatic, 10.14 (10.72) Manual			
	With air cond.—L.(qt.)	10.39 (10.98) Automatic, 10.49 (11.09) Manual			
	Opt. equipment [specify—L.(qt.)]	10.55 (11.15) Automatic & Manual, H.D. Radiator			
Water jackets full length of cyl. (yes, no)		Yes			
Water all around cylinder (yes, no)		Yes			
Radiator core	Describe (type, material, no. of rows)	Cross-flow, copper-brass, high efficiency radiator			
	Std., A/C, HD	Auto.Std.	Auto. A/C or H.D.	Man.Std.	Man. A/C or H.D.
	Width	600.0	600.0	600.0	600.0
	Height	303.2	387.5	303.2	387.5
	Thickness	25.0	25.0	25.0	25.0
	Fins per inch	3.0*	3.5*	4.0*	3.5*
Fan	Std., elec., opt.	Std. Elec.		A/C Elec.	
	Number of blades & type (flex, solid, material)	4, Plastic, Solid		7, Plastic, Solid	
	Diameter & projected width	291.0		357.0	
	Ratio (fan to crankshaft rev.)	Not Applicable			
	Fan cutout type	ECM Controlled			
	Drive [type (direct, remote)]	Direct			
	RPM at idle (elec.)	1900		2700	
	Motor rating (wattage) (elec.)	97		150	
	Motor switch (type & location) (elec.)	Engine temperature switch, engine cylinder head			
	Switch point (temp., pressure) (elec.)	110.5°C			
Fan shroud (material)	None				

* - Distance between top of fins.

MVMA Specifications Form Passenger Car

Car Line CITATION II
Model Year 1985 Issued 7-84 Revised (●) _____

METRIC (U.S. Customary)

Engine Description/Carb. Engine Code

2.5 LITER L4 (151 CID)	2.8 LITER V6 (173 CID)	
ELECTRONIC FUEL INJ.	2 BBL. CARBURETOR	2.8 MULTI-PORT FI
RPO LR8	RPO LE2	RPO LB6

Engine - Fuel System (See supplemental page for details of Fuel Injection, Supercharger, Turbocharger, etc. if used)

Induction type: carburetor, fuel injection system, etc.		CCC Controlled Fuel Injection	Carburetor	CCC Controlled Fuel Injection	
Carburetor	Mfr.	Rochester	Rochester	Rochester	
	Choke (type)	None	Electric	None	
	Idle spd. -rpm (spec. neutral or drive and propane if used)	Manual	ECM	800 (Neutral)	ECM
		Automatic	Controlled - No Adjustment	--	Controlled- No Adjustment
Idle A/F mix.		Preset - no adjustment provided			
Fuel injection	Point of injection (no.)	Throttle body, one		Fuel injectors at- Pulse inlet ports	
	Constant, pulse, flow	Pulse		ECM	
	Control (electronic, mech.)	ECM			
	System pressure (kPa (psi))	(11 psi)			
Intake manifold heat control (exhaust or water thermostatic or fixed)		Water	Exhaust	Water	
Air cleaner type	Standard	Replaceable paper element, single snorkel			
	Optional	None			
Fuel pump	Type (elec. or mech.)	Electric	Mechanical	Electric	
	Location (eng., tank)	In fuel tank	On eng left frt	In fuel tank	
	Pressure range (kPa (psi))	83 (12.0)	41-52 (6.0-7.5)		

Fuel Tank

Capacity (refill L (gallons))		55.3 (14.6) Approx.	57.2 (15.1) Approx.	55.3 (14.6) Approx.
Location (describe)		Underside - rear center		
Attachment		Underbody strap		
Material		Steel		
Filler pipe	Location & material	Left rear quarter		
	Connection to tank	Solid solder		
Fuel line (material)		Steel		
Fuel hose (material)		Rubber		
Return line (material)		Steel		
Vapor line (material)		Steel		
Extended range tank	Opt., n.a.	Not Available		
	Capacity (L (gallons))	"		
	Location & material	"		
	Attachment	"		
Auxiliary tank	Opt., n.a.	Not Available		
	Capacity (L (gallons))	"		
	Location & material	"		
	Attachment	"		
	Selector switch or valve	"		
Separate fill		"		

Specifications Form
Passenger Car

Model Year 1985 Issued 7-84 Revised (●) _____

METRIC (U.S. Customary)

Engine Description/Carb.
 Engine Code

2.5 LTR.L4(151 CID)	2.8 LITER V6 (173 CID)
ELECTRONIC FUEL INJ.	2-BBL. CARBURETOR
RPO LR8	RPO LE2
	2.8 MULTI-PORT F RPO LB6

Vehicle Emission Control

Air Injection	Type (air injection, engine modifications, other)	CCC Control with Fuel Injection	CCC Control with Air Injection	CCC Control with Fuel Injection
	Pump or pulse	Not Available	Vane	Not Available
	Driven by	"	V-Belt	"
	Air distribution (head, manifold, etc.)	"	Exh. manif., conv.	"
Exhaust Emission Control	Point of entry	"	Exh. manif. ports	"
	Exhaust Gas Recirculation	Controlled flow		
	Type (controlled flow, open orifice, other)	Exhaust manifold	R.H. bank	Exhaust Manifold
Catalytic Converter	Point of exhaust injection (spacer, carburetor, manifold, other)	Inlet manifold		
	Type	S Bed, Ox & Red	D Bed, Ox & Red	S Bed, Ox & Red
	Number of	One		
	Location(s)	Mounted to underbody at #2 body bar		
	Volume [L (in ³)]	2.6 (160)	2.8 (170)	2.8 (170)
Crankcase Emission Control	Substrate type	Pellets	Monolith	Monolith
	Type (ventilates to atmosphere, induction system, other)	Induction system		
	Energy source (manifold vacuum, carburetor, other)	Manifold vacuum		
	Discharges (to intake manifold, other)	Inlet manifold		
Evaporative Emission Control	Air inlet (breather cap, other)	Carburetor air cleaner		
	Vapor vented to (crankcase, canister, other)	Fuel tank Canister	Canister	--
	Vapor storage provision	Canister		
Electronic system	Closed loop (yes-no)	Yes		
	Open loop (yes-no)	No		

Engine - Exhaust System

Type (single, single with cross-over, dual, other)	Single	Sgle w/cross-over	Sgle w/cross-over@
Muffler no. & type (reverse flow, straight thru, separate resonator)	One, reverse flow		
Resonator no. & type	None		
Exhaust pipe	Branch o.d., wall thickness	--	50.8x.81(2.0x.032)(2)
	Main o.d., wall thickness	50.8x1.12(2.0x.044)	47.8x1.42(1.875x.056)
	Material	Alum. coated steel (1)	
Inter-mediate pipe	o.d. & wall thickness	--	50.8x1.09(2.00x.043) 57.15x1.4(2.25x.043)
	Material	Aluminum coated steel	
Tail pipe	o.d. & wall thickness	50.8x1.4(2.0x.06)	44.5x1.09(1.75x.043) 50.8x1.4(2.00x.056)
	Material	Alum. coated steel	Alum. coated steel

- @ - with dual tailpipes.
- (1) - Stainless steel pipe with aluminum coated steel heat shield.
- (2) - Laminated tubing, steel inner, stainless steel outer.

MVMA Specifications Form Passenger Car

Car Line CITATION ii
 Model Year 1985 Issued 7-84 Revised (•) _____

METRIC (U.S. Customary)

Engine Description/Carb.
Engine Code

2.5 LITER L4 (151 CID) ELECTRONIC FUEL INJ. RPO LR8	2.8 LITER V6 (173 CID) 2-BBL. CARB. RPO LE2	2.8 MULTI-PORT FI RPO LB6
-----------------------------------------------------------	---------------------------------------------------	------------------------------

Transmissions/Transaxle

Manual 3-speed (std., opt., n.a.)	Not Available
Manual 4-speed (std., opt., n.a.)	Standard
Manual 5-speed (std., opt., n.a.)	Not Available
Manual overdrive (std., opt., n.a.)	"
Automatic (std., opt., n.a.)	Optional
Automatic overdrive (std., opt., n.a.)	Not Available

Manual Transmission/Transaxle

Number of forward speeds	4			
Transmission ratios	In first	3.53	3.53	3.31
	In second	1.95	1.95	1.95
	In third	1.24	1.24	1.24
	In fourth	0.73	0.81	0.90
	In fifth	--	--	--
	In overdrive	--	--	--
	In reverse	3.42	3.42	3.42
Synchronous meshing (specify gears)	All forward gears			
Shift lever location	Floor mounted			
Lubricant	Capacity (L (pt.))	2.8 (5.9) (a)		
	Type recommended	Automatic transmission fluid		
	SAE viscosity number	Summer	transmission fluid	
		Winter	fluid	
	Extreme cold			

Clutch (Manual Transmission)

Make, type, engagement (describe)	Borg & Beck, dry single plate			
Type pressure plate springs	Diaphragm			
Total spring load [N (lb.)]	5647 (1245)	6227 (1400)		
No. of clutch driven discs	One			
Clutch facing	Material	Woven molded asbestos		
	Manufacturer	Borg & Beck		
	Part number	476600	14085579	14085576
	Rivets/plate	36	32	
	Rivet size	3.6 x 5.4 (.143 x .213)		
	Outside & inside dia.	232 x 155 (9.12 x 6.12)		
	Total eff. area (cm ² (in. ²))	232 (35.9)		
	Thickness	7.37-7.87 (.290 - .310)	7.49-8.00 (.295-.315)	
Engagement cushion method	Driven plate wave spoke springs			
Release bearing	Type & method of lubrication	Ball thrust - prepacked and sealed		
Torsional damping	Method: springs, friction material	Coil springs & metal to metal friction		

(a) Also lubricant for differential

MVMA Specifications Form

Passenger Car

Model Year 1985 Issued 7-84 Revised (*)

METRIC (U.S. Customary)

Engine Description/Carb.
Engine Code

2.5 LITER L4 (151 CID) ELECTRONIC FUEL INJ. RPO LB8	2.8 LITER V6 (173 CID)	
	2-BBL. CARB RPO LE2	2.8 MULTI-PORT RPO LB6
FINAL DRIVE	2.39 2.84	2.53 3.23 3.65 3.33

Automatic Transmission/Transaxle

Trade name	3-Speed Automatic
Type and special features (describe)	3-Speed with torque converter clutch
Selector	Location Floor mounted on console
	Ltr./No. designation P-R-N-D-2-1
Gear ratios	R 2.07
	D 1.00
	L ₃ 1.60
	L ₂ 2.84
	L ₁ Not Applicable
Max. upshift speed - drive range [km/h (mph)]	Not Available
Max. kickdown speed - drive range [km/h (mph)]	"
Min. overdrive speed [km/h (mph)]	Not Applicable
Torque converter	Number of elements 3
	Max. ratio at stall Not Available
	Type of cooling (air, liquid) Liquid
	Nominal diameter 245 (9.65)
Lubricant	Capacity (refill L (pt.)) 4.0L (8.46 pts)
	Type Recommended Dexron II
Oil cooler (std., opt., NA, internal, external, air, liquid)	Integral with radiator

Axle or Front Wheel Drive Unit

Type (front, rear)	Front	
Description	Front differential with helical gears and tapered roller bearings.	
Limited slip differential (type)	None	
Drive pinion offset	Not Applicable	
Drive pinion (type)	"	
No. of differential pinions	2	
Pinion / differential adjustment (shim, other)	Not Applicable	
Pinion / differential bearing adjustment (shim, other)	"	
Driving wheel bearing (type)	Sealed ball bearings (Integral part of bolt-in hub units)	
Lubricant	Capacity (L (pt.)) Not applicable, part of automatic transmission assembly.	
	Type recommended Automatic transmission fluid	
	SAE viscosity number	Summer " Winter " Extreme cold "

Axle or Transaxle Ratio and Tool Combinations (See 'Power Teams' for axle ratio usage.)

Axle ratio (or overall top gear ratio)	3.32	2.84	2.84	3.32	2.84	3.65	3.18
No. of teeth	Pinion (Drive Gear)	25	38	37	25	35	23
	Ring gear or gear (Driven Gr)	83	32	33	83	35	84
Ring gear o.o. *(Pitch Dia.)	195.2						
Transaxle	Transfer gear ratio	0.81	1.0	1.0	.73	1.0	0.81
	Final drive ratio	2.69	2.39	2.53	2.42	2.84	2.96

* - Driven Gear

Torrance, CA 90503 # PV118E

MVMA Specifications Form Passenger Car

Car Line CITATION II
 Model Year 1985 Issued 7-84 Revised (●) _____

METRIC (U.S. Customary)

Engine Description/Carb.
Engine Code

2.5 LITER L4 (151 CID) ELECTRONIC FUEL INJ. RPO LR8	2.8 LITER V6 (173 CID) 2-BBL. CARB. RPO LE2	2.8 MULTI-PORT FI RPO LB6
-----------------------------------------------------------	---------------------------------------------------	------------------------------

Axle Shafts – Front Wheel Drive

Number used		Two	
Type (straight, solid bar, tubular, etc.)		Left	Straight solid bar
		Right	Straight solid bar
Outer diam. x length* x wall thickness	Manual transmission	Left	23.91 x 352.95
		Right	23.91 x 757.15
	Automatic transmission	Left	23.91 x 352.95
		Right	23.91 x 453.95
	Optional transmission	Left	None
		Right	"
Slip yoke	Type		"
	Number of teeth		"
	Spline o.d.		None
Universal joints	Make and mfg. no.	Inner	Saginaw
		Outer	Saginaw
	Number used		4
	Type, size, plunge	Inner	Double offset design
		Outer	Rzeppa
	Attach (u-bolt, clamp, etc.)		Splined
	Bearing	Type (plain, anti-friction)	Anti-friction
Lubrication (fitting, prepack)		Prepack	
Drive taken through (torque tube, arms or springs)		Wishbone lower control arm; upper MacPherson strut	
Torque taken through (torque tube, arms or springs)		Engine mounting system	

* Centerline to centerline of universal joints, or to centerline of attachment.

Passenger Car
METRIC (U.S. Customary)

Model Year 1985 Issued 7-84 Revised (●) _____

Body Type And/Or
 Engine Displacement

2.5 LITER L4 (151 CID) ELECTRONIC FUEL INJ. RPO LR8	2.8 LITER V6 (173 CID) 2-BBL CARB. 2.8 MULTI-PORT F RPO LE2	RPO LB6
-----------------------------------------------------------	-------------------------------------------------------------------	---------

Suspension - General

Car leveling	Std. opt. n.a.	Not available
	Type (air, hyd., etc.)	Not available
	Manual/auto. controlled	Not available
Provision for brake dip control		Front suspension geometry
Provision for accel. squat control		Rear suspension geometry
Provisions for car jacking		Position jack in opening in bumper lower face of front and rear bumpers.
Shock absorber (front & rear)	Type	Front-MacPherson Strut; Rear-direct, Double Acting Hydr
	Make	Delco
	Piston diameter	Front- 32 (1.26); Rear - 25 (1.0)
	Rod diameter	13.49 (0.53)

Suspension - Front

Type and description		MacPherson with coil springs, stamped lower control arms and nodular iron steering knuckles.
Drive and torque taken through		
Travel	Full jounce	95.0 mm (3.7 in)
	Full rebound	89.0 mm (3.5 in)
Spring	Type (coil, leaf, other) & material	Coil, Steel
	Insulators (type & material)	
	Size (coil design height & i.d., bar length x dia.)	500.4 x 44.4 x 3082 x 13.4 (19.7 x 1.75 x 121.3 x 0.528)
	Spring rate [N/mm (lb./in.)]	16.0(91.0) Base & F41, 19.5(111.0) F40, 23.5 (134.0) Z19
	Rate at wheel [N/mm (lb./in.)]	18.8(107.0) Base & F41, 22.1(126.0) F40, 25.7 (147.0) Z19
Stabilizer	Type (link, linkless, frameless)	Link
	Material & bar diameter	Steel - 22 (0.866)

Suspension - Rear

Type and description		Trailing arm with stamped control arms and open section transverse beam	
Drive and torque taken through		Not Applicable	
Travel	Full jounce	92.0 mm (3.62 in)	
	Full rebound	108.0 mm (4.25 in)	
Spring	Type (coil, leaf, other) & material	Coil, Steel	
	Size (length x width, coil design height & i.d., bar length & dia.)	364 x 108 x 2550 x 12.2 (14.3 x 4.25 x 100.4 x 0.480)	
	Spring rate [N/mm (lb./in.)]	26.9 (154.0) Base & F41, 32.0 (183.0) F40 & Z19	
	Rate at wheel [N/mm (lb./in.)]	15.5 (88.0) Base & F41, 18.3 (104.0) F40 & Z19	
	Insulators (type & material)	Rubber - top only	
	If leaf	No. of leaves	Not Applicable
		Shackle (comp. or tens.)	Not Applicable
Stabilizer	Type (link, linkless, frameless)	Integral function performed by axle beam.	
	Material & bar diameter	Seamless Steel Tubing; 20 (0.79)	
Track bar (type)		Transverse Beam Design; 30 (1.18)	

Torrance, CA 90503 # PV110E

MVMA Specifications Form Passenger Car

METRIC (U.S. Customary)

Car Line CITATION II
Model Year 1985 Issued 7-84 Revised (•) _____

Body Type And/Or
Engine Displacement

2.5 LITER L4 (151 CID) ELECTRONIC FUEL INJ. RPO LR8	2.8 LITER V6 (173 CID) 2-BBL. CARB. RPO LE2	2.8 MULTI-PORT FI RPO LB6
-----------------------------------------------------------	---------------------------------------------------	------------------------------

Brakes - Service

Description			Single caliper disc front, duo-servo drum rear			
Brake type (std., opt., n.a.)	Front (disc or drum)		Disc			
	Rear (disc or drum)		Drum			
Self-adjusting (std., opt., n.a.)			Standard			
Special valving	Type (proportion, delay, metering, other)		Proportioning, diagonal/split circuit			
Power brake (std., opt., n.a.)			Optional (a)	Required option		
Booster type (remote, integral, vac., hyd., etc.)			Tandem			
Vacuum source (inline, pump, etc.)			Inline (intake manifold)			
Vacuum reservoir (volume in. ³)			None			
Vacuum pump-type (elec, gear driven, belt driven, if other so state)			None			
Anti-skid device type (std., opt., n.a.) (F/R)			Not Available			
Effective area [cm ² (in. ²)]*			530.6 (82.26)			
Gross lining area [cm ² (in. ²)]**(F/R)			620.3 (96.17)			
Swept area [cm ² (in. ²)]**(F/R)			1687.2 (261.58)			
Rotor	Outerworking diameter		F/R	247 (9.72) /--		
	Inner working diameter		F/R	Not Available		
	Thickness		F/R	22 (0.87) /--		
	Material & type (vented/solid)		F/R	Cast iron, vented /--		
Drum	Diameter & width		F/R	--/ 200 x 45 (7.87 x 1.77)		
	Type and material		F/R	--/ Cast iron		
Wheel cylinder bore			74.6 (2.9375) / 17 (0.67)			
Master cylinder	Bore/stroke		F/R	22 (0.87) / 35.52 (1.40)		
Pedal arc ratio			Manual - 6.6:1			
Line pressure at 445 N(100 lb.) pedal load [kPa (psi)]			Not Available			
Lining clearance			(F/R)	Self adjusting / self adjusting		
Brake lining	Front wheel	Bonded or riveted (rivets/seg.)		Riveted, 6		
		Rivet size		7.37 x 3.63 (.290 x .143)		
		Manufacturer		Delco Moraine		
		Lining code		Not Available		
		Material		Organic	Metallic	
		****	Primary or out-board		125 x 59 x 10.85 (4.92 x 2.32 x 0.430)	
		Size	Secondary or in-board		125 x 59 x 10.85 (4.92 x 2.32 x 0.430)	
	Shoe thickness (no lining)		Inboard - 4.72 (0.186); outboard - 3.14 (0.124)			
	Rear wheel	Bonded or riveted (rivets/seg.)		Riveted, 8		
		Manufacturer		Delco Moraine		
		Lining code		Not Available		
		Material		Organic		
		****	Primary or out-board		167.7 x 43.9 x 3.8 (6.60 x 1.73 x 0.15)	
		Size	Secondary or in-board		203.3 x 43.9 x 4.8 (8.0 x 1.73 x 0.19)	
Shoe thickness (no lining)		2.75 (.106)				

*Excludes rivet holes, grooves, chamfers, etc.

**Includes rivet holes, grooves, chamfers, etc.

***Total swept area for four brakes. (Drum brake: Widest lining contact width for each brake x its contact circumference.)
(Disc brake: Square of Outer Working Dia. minus Square of inner Working Dia. multiplied by Pi/2 for each brake.)

****Size for drum brakes includes length x width x thickness.

(a) Required with RPO C60 air conditioning

Passenger Car

Model Year 1985 Issued 7-84 Revised (●)

METRIC (U.S. Customary)

Body Type And/Or
Engine Displacement

2-DOOR HATCHBACK COUPE 1XX08	4-DOOR HATCHBACK SEDAN 1XX68
------------------------------------	------------------------------------

Tires And Wheels (Standard)

Tires	Size (load range, ply)		P185/80R-13 (BW, WS)* (1)
	Type (bias, radial, etc.)		Steel belted radial
	Inflation pressure (cold) for recommended max. vehicle load	Front (kPa (psi))	240 (35)
		Rear (kPa (psi))	240 (35)
Rev./mile—at 70 km/h (45 mph)		526	
Wheels	Type & material		Ventilated, semi-styled disc, steel
	Rim (size & flange type)		13 x 5.5
	Wheel offset		42 mm
	Attachment	Type (bolt or stud)	Stud
		Circle diameter	100 mm
Number & size		5-M12 x 1.5	
Spare	Tire and wheel (same, if other describe)		14 x 4 wheel; compact spare tire - T125/70D14-415 (60)
	Storage position & location (describe)		Flat under rear load floor

Tires And Wheels (Optional)

* Not available with RPO F41 sport suspension		
Size (load range, ply)		P205/70R13 WL** (1)
Type (bias, radial, etc.)		Steel belted radial
Wheel (type & material)		Steel
Rim (size, flange type and offset)		13 x 5.5, 42.0 (1.65) offset
Size (load range, ply)		P215/60R14 BW, WL**
Type (bias, radial, etc.)		Steel belted radial
Wheel (type & material)		Aluminum
Rim (size, flange type and offset)		14 x 6.5, 34.0 (1.34) offset
Size (load range, ply)		
Type (bias, radial, etc.)		
Wheel (type & material)		
Rim (size, flange type and offset)		
Size (load range, ply)		
Type (bias, radial, etc.)		
Wheel (type & material)		
Rim (size, flange type and offset)		
Spare tire and wheel		
If configuration is different than road tire or wheel, describe optional spare tire and/or wheel location & storage position		15 x 4 wheel, compact spare tire, T135/80D15, 415 (60) with P215/60R14 tires only.

Brakes - Parking

** - Requires RPO F41 sport suspension.		
Type of control		Application - foot operated; release - 'I' handle
Location of control		Under instrument panel, left of steering column
Operates on		Rear service brakes
If separate from service brakes	Type (internal or external)	--
	Drum diameter	--
	Lining size (length x width x thickness)	--

(1) - "All Seasons" mud and snow, 4th generation, GM TPC tires.

Torrance, CA 90503 #PV118E

MVMA Specifications Form Passenger Car

Car Line CITATION II
 Model Year 1985 Issued 7-84 Revised (e) _____

METRIC (U.S. Customary)

Body Type And/Or
Engine Displacement

2.5 LITER L4 (151 CID) ELECTRONIC FUEL INJ. RPO LR8	2.8 LITER V6 (173 CID) 2-BBL. CARB. RPO LEZ	2.8 MULTI-PORT FI RPO LB6
-----------------------------------------------------------	------------------------------------------------	------------------------------

Steering

Manual (std., opt., n.a.)		Standard		
Power (std., opt., n.a.)		Optional		
Adjustable steering wheel (tilt, swing, other)	Type and description	Tilt		
	(Std., opt., n.a.)	Optional		
Wheel diameter	Manual	387 (15.2)		
	Power	387 (15.2)		
Turning diameter m (ft.)	Outside front	Wall to wall (l. & r.)	12.5 (41.0)	
		Curb to curb (l. & r.)	11.7 (38.4)	
	Inside rear	Wall to wall (l. & r.)	Not Available	
		Curb to curb (l. & r.)	"	
Scrub Radius		"		
Manual	Gear	Type	Rack & Pinion	
		Make	Saginaw Steering Gear	
		Ratios	Gear Overall	Not Available
	No. wheel turns (stop to stop)		26.0:1	
Power	Type (coaxial, linkage, etc.)		Rack & Pinion W/End Take-Off Tie Rods - Integral	
	Make		Saginaw Steering Gear	
	Gear	Type	Rack & Pinion With Integral Power Unit	
		Ratios	Gear Overall	Not Available
	Pump (drive)		17.5:1	
No. wheel turns (stop to stop)		'V' Belt		
Linkage	Type		End Take-Off Tie Rods	
	Location (front or rear of wheels, other)		Rear	
	Drag links (trans. or longit.)		None	
	Tie rods (one or two)		Two	
Steering axis	Inclination at camber (deg.)		14.5	
	Bearings (type)	Upper	Ball Stud	
		Lower	Ball Stud	
	Thrust		Not Available	
Steering spindle & joint type		"		
Wheel spindle	Diameter	Inner bearing	28.95 (1.1398)	
		Outer bearing	28.95 (1.1398)	
	Thread (size)		M20 x 2.5	
	Bearing (type)		Integral Double Row Ball, Permanently lubricated.	

MVMA SPECIFICATIONS Form

Passenger Car

METRIC (U.S. Customary)

Model Year 1985 Issued 7-84 Revised (●)

Body Type And/Or
Engine Displacement

2-DOOR HATCHBACK COUPE 1XX08	4-DOOR HATCHBACK SEDAN 1XX68
------------------------------------	------------------------------------

Wheel Alignment

Front wheel at curb mass (wt.)	Service checking	Caster (deg.)	2.0° +/- 2° left & right side should be equal within
		Camber (deg.)	0.0° +/- 1.0°
		Toe-in [outside track-mm (in.)]	0.0° +/- 0.4° total
	Service reset*	Caster	Not Adjustable
		Camber	0.0° +/- 0.5°
		Toe-in	0.0° +/- 0.2° total
Periodic M.V. inspection	Caster	Not Adjustable	
	Camber	0.0° +/- 1.0°	
	Toe-in	0.0° +/- 0.4° total	
Rear wheel at curb mass (wt.)	Service checking	Camber (deg.)	Not Applicable
		Toe-in [outside track-mm (in.)]	"
	Service reset*	Camber	"
		Toe-in	"
	Periodic M.V. inspection	Camber	"
		Toe-in	"

* Indicates pre-set, adjustable, trend set or other.

Electrical— Instruments and Equipment

Speedometer	Type	In-line with pointer
	Trip odometer (std., opt., n.a.)	Optional
EGR maintenance indicator		"
Charge indicator	Type	Tell-Tale warning light (gauge optional)
	Warning device	" " " "
Temperature indicator	Type	Tell-Tale warning light (gauge optional)
	Warning device	" " " "
Oil pressure indicator	Type	Tell-Tale warning light (gauge optional)
	Warning device	" " " "
Fuel indicator	Type	Electric gauge with pointer
	Warning device	" " " "
Windshield wiper	Type (standard)	Electric 2-speed
	Type (optional)	Intermittent
	Blade length	454 (18")
	Swept area [cm ² (in. ²)]	5514 (854.9)
Windshield washer	Type (standard)	Electric push-button on turn signal lever
	Type (optional)	Not Available
	Fluid level indicator	"
Horn	Type	Electric vibrator
	Number used	One
Other		Parking brake warning light & brake failure warning restraint system warning light and buzzer, Odometer f for converter service, "choke" malfunction tell-tale warning light - (California only)

Torrance, CA 90503 # PV119E

MVMA Specifications Form Passenger Car

Car Line CITATION II
 Model Year 1985 Issued 7-84 Revised (●) _____

METRIC (U.S. Customary)

Engine Description/Carb.
Engine Code

2.5 LITER L4 (151 CID) ELECTRONIC FUEL INJ. RPO LR8	2.8 LITER V6 (173 CID) 2-BBL. CARB 2.8 MULTI-PORT FI RPO LE2 RPO LB6
-----------------------------------------------------------	--------------------------------------------------------------------------------

Electrical - Supply System

Battery	Make	Delco Remy		
	Model, std., (opt.)	70-405(a), 75-500(b)		70-315(a), 75-500(b) (f)
	Voltage	12 Volt		
	Amps at 0°F cold crank	405(a), 500(b)		405(a), 500(b) 500(a), 630(b)
	Minutes-reserve capacity	75 minutes(a), 90 minutes(b)		75 minutes(a), 90 minutes(b) (f)
	Amp/hrs. - 20 hr. rate	--		
Location	L.H. side of engine compartment			
Generator or alternator	Type and rating	(c,d,e)		
	Ratio (alt. crank/rev.)	2.73:1(c,d), 2.51:1(e)		2.72:1 2.35:1
	Optional (type & rating)	None		
Regulator	Type	Integral with alternator		

Electrical - Starting System

Start. motor	Current drain at 0°F -20°F	325	235	250
	Engagement type	Overrunning clutch		
Motor drive	Pinion engages from (front, rear)	Front	Rear	

Electrical - Ignition System

Type	Conventional (std., opt., n.a.)	Not Available		
	Electronic (std., opt., n.a.)	"		
	Other (specify)	High energy ignition (integral with distributor)		
Coil	Make	Delco-Remy		
	Model	Not Available	1115463	Not Available
	Current	Engine stopped - A	0	
		Engine idling - A	5.5 Max.	
Spark plug	Make	AC		
	Model	R44TSX	R43CTS	R42CTS
	Thread (mm)	M14 x 1.25		
	Tightening torque [N-m (lb., ft.)]	20-34 (15-25)		9-20 (7-15)
	Gap	1.524 (.060)		1.143 (.045)
	Number per cylinder	One		
Distributor	Make	Delco-Remy		
	Model	Not Available	1103569	Not Available

Electrical - Suppression

Locations & type Internal alternator capacitor, non-metallic high-tension ignition cables, resistor spark plugs, ignition coil by-pass capacitor, internal AC blower motor by-pass capacitor & A/C compression diode, with radio provisions; horn grounding clip, engine to dash panel ground strap, fuse block capacitor and on "heater only" blower motors and coax capacitor.

- (a) - Standard
- (b) - Optional
- (c) - 42 AMP with heater, 10 SI (22 AMP @ idle), with LB6 - 56 amp.
- (d) - 66 AMP with heater and heated backlight, 10 SI (23 AMP @ idle)
- (e) - 78 AMP with A/C, 15 SI (40 AMP @ idle), with LB6 - 94 amp with A/C
- (f) - 75-500 Base RPO LB6 engine, UA1 75-630.
- (g) - 90 Minutes reserve capacity, base & UA1.

MVMA Specifications Form Passenger Car

Model Year 1985 Issued 7-84 Revised (●)

METRIC (U.S. Customary)

Body Type

2-DOOR HATCHBACK COUPE 1XX08	4-DOOR HATCHBACK SEDAN 1XX68
------------------------------------	------------------------------------

Body - Miscellaneous Information

Type of finish (lacquer, enamel, other)	Acrylic lacquer or water base acrylic enamel	
Hood	Hinge location (front, rear)	Rear
	Type (counterbalance, prop)	No
	Release control (internal, external)	Internal
Trunk lid	Type (counterbalance, other)	Not available
	Internal release control (elec., mech., n.a.)	"
Hatchback lid	Type (counterbalance, other)	2-Telescoping gas strut rods
	Internal release control (elec., mech., n.a.)	"
Bumper front	Bar material & mass, kg (weight, lbs.)	Steel 12.054 (26.6)
	Reinforcement material & mass, kg (lbs.)	None
Bumper rear	Bar material & mass, kg (weight, lbs.)	Steel 12.984 (28.6)
	Reinforcement material & mass, kg. (lbs.)	None
Vent window control (crank, friction, pivot, power)	Front	"
	Rear	"
Seat cushion type (e.g., 60/40, bucket, bench, wire, foam etc.)	Front	Bench* Polyurethane Padding
	Rear	Bench Polyurethane Padding
	3rd seat	None
Seat back type (e.g., 60/40, bucket, bench, wire, foam etc.)	Front	Bench* Polyurethane Padding
	Rear	Bench Polyurethane Padding
	3rd seat	None
Vehicle identification no. location	Top left hand in instrument panel pad	

Frame

Type and description (separate frame, unitized frame, partially-unitized frame)	Top left hand in instrument panel pad *Bucket seat optional Unitized frame. Bolt-on power train cradle (2-piece design) with mounting provisions for suspension lower control arms and engine mounts.
---------------------------------------------------------------------------------	-----------------------------------------------------------------------------------------------------------------------------------------------------------------------------------------------------------------

Glass

Backlight slope angle (deg.)	H121	65.0°	
Windshield slope angle (deg.)	H122	57.0°	
Tumble-Home (deg.)	W122	22.0°	
Windshield glass exposed surface area (cm ² (in. ²))	S1	8362 (1296.1)	
Side glass exposed surface area (cm ² (in. ²)) - total 2-sides	S2	12935 (2004.9)	12863 (1993.8)
Backlight glass exposed surface area (cm ² (in. ²))	S3	7216 (1118.5)	
Total glass exposed surface area (cm ² (in. ²))	S4	28513 (4419.5)	28441 (4408.4)
Windshield glass (type)		Curved - Laminated Plate	
Side glass (type)		Curved - Tempered Plate	
Backlight glass (type)		Curved - Tempered Plate	

MVMA Specifications Form
Passenger Car
METRIC (U.S. Customary)

Car Line CITATION II
 Model Year 1985 Issued 7-84 Revised (●) _____

Body Type

2-DOOR HATCHBACK COUPE 1XX08	4-DOOR HATCHBACK SEDAN 1XX68
------------------------------------	------------------------------------

Restraint System

Active restraint system	Standard/optional	Standard
	Type and description	3 Point shoulder and lap belt for driver and front passenger. Lap belt for all other positions.
	Location	Front-(2); Rear-(3)
Passive seat belts	Standard/optional	Not available
	Power/manual	"
	2 or 3 point	"
	Knee bar/lap belt	"

**Passenger Car
METRIC (U.S. Customary)**

Model Year 1985 Issued 7-84 Revised (●) _____

Body Type

2-DOOR HATCHBACK COUPE 1XX08	4-DOOR HATCHBACK SEDAN 1XX68
------------------------------------	------------------------------------

Convenience Equipment (standard, optional, n.a.)

Air conditioning (manual, auto. temp control)	Optional (manual control)	
Clock (digital, analog)	Optional, digital, integral with radio	
Compass / thermometer	Not Available	
Console (floor, overhead)	Optional, floor	
Defroster, elec. backlight	Optional	
Electronic	Diagnostic warning (integrated, individual)	Not Available
	Instrument cluster (list instruments)	"
	Keyless entry	"
	Trip/finder (avg. spd., fuel)	"
	Voice alert (list items)	"
	Other	"
	--	
Fuel door lock (remote, key, electric)	Not Available	
Lamps	Auto head on / off delay, dimming	"
	Cornering	"
	Courtesy (map, reading)	*
	Door lock, ignition	Not Available
	Engine compartment	*
	Fog	Not Available
	Glove compartment	*
	Trunk	*
Other	* Ash Tray	
	--	
Mirrors	Day/night (auto. man.)	Standard, manual
	L.H. (remote, power, heated)	Optional, remote
	R. H. (convex, remote, power, heated)	Optional, convex
	Visor vanity (RH / LH, illuminated)	Optional, RH - not illuminated
Parking brake-auto release (warning light)	Manual release, warning light	
Power equipment	Door locks - deck lid - security	Optional, door locks
	Seat (2-4-6 way) heated (driver, pass, other) lumbar, hip, thigh support (power, manual) reclining (driver, pass) memory (1-2 preset, recline)	Not Available
	Side windows	Optional (coupes, frt doors; sedans, frt & rr doors)
	Vent windows	Not Available
	Rear window	"
	--	
Radio systems	Antenna (location, whip, w shield, power)	Whip, R.F. fender mounted, manual only
	AM, FM, stereo, tape, CB	AM, AM/FM, AM/FM stereo with/without cassette tape
	Speaker (number, location) Premium sound	Two front std., two rear std. w/stereo, opt. w/mono
Roof open air/fixd (flp-up, sliding, "T")	Not Available	
Speed control device	Optional, with auto trans. & power brakes only	
Speed warning device (light, buzzer, etc.)	Not Available	
Tachometer (rpm)	Optional	
Theft protection-type	Lock mounted on steering column; locks steering wheel transmission shift levers and ignition.	

* Available in optional lighting package only consists of following:
Luggage compartment lamp, underhood lamp, glove compartment lamp,
ash tray lamp, courtesy lamps, buzzer - headlamp on.

MVMA Specifications Form

Passenger Car

Car Line CITATION II
 Model Year 1985 Issued 7-84 Revised (e) 9-84

METRIC (U.S. Customary) Car and Body Dimensions See Key Sheets for definitions

All dimensions to ground are for comparative purposes only. Dimensions are to be shown for all base body models of each car line. SAE Ref. no. refers to the definition published in SAE Recommended Practice J1100a "Motor Vehicle Dimensions," unless otherwise specified.

Body Type	SAE Ref. No.	2-DOOR HATCHBACK COUPE 1XX08	4-DOOR HATCHBACK SEDAN 1XX68
-----------	--------------	------------------------------	------------------------------

Width

Measurement	SAE Ref. No.	2-DOOR HATCHBACK COUPE 1XX08	4-DOOR HATCHBACK SEDAN 1XX68
Tread (front)	W101	1492 (58.7)	
Tread (rear)	W102	1447 (57.0)	
Vehicle width	W103	1736 (68.3)	
Body width at Sg RP (front)	W117	1730 (68.1)	1727 (68.0)
Vehicle width (front doors open)	W120	3680 (144.9)	3219 (126.7)
Vehicle width (rear doors open)	W121	--	2857 (112.5)

Length

Measurement	SAE Ref. No.	2-DOOR HATCHBACK COUPE 1XX08	4-DOOR HATCHBACK SEDAN 1XX68
Wheelbase	L101	2664 (104.9)	
Vehicle length	L103	4488 (176.7)	
Overhang (front)	L104	897 (35.3)	
Overhang (rear)	L105	927 (36.5)	
Upper structure length	L123	2752 (108.3)	
Rear wheel C.L. "X" coordinate	L127	2459 (96.8)	
Cowl point "X" coordinate	L125	215 (8.5)	

Height **

Measurement	SAE Ref. No.	2-DOOR HATCHBACK COUPE 1XX08	4-DOOR HATCHBACK SEDAN 1XX68
Passenger distribution (fr./rear)	PD1,2,3		**
Trunk cargo load			**
Vehicle height	H101	1368 (53.9)	
Cowl point to ground	H114	911 (35.9)	
Deck point to ground	H138		
Rocker panel-front to ground	H112	216 (8.5)	
Bottom of door closed-front to grd.	H133	286 (11.3)	
Rocker panel-rear to ground	H111	215 (8.5)	
Bottom of door closed-rear to grd.	H135	--	285 (11.2)

Ground Clearance **

Measurement	SAE Ref. No.	2-DOOR HATCHBACK COUPE 1XX08	4-DOOR HATCHBACK SEDAN 1XX68
Front bumper to ground	H102	355 (14.0)	
Rear bumper to ground	H104	329 (13.0)	
Bumper to ground (front at curb mass (wt.))	H103	374 (14.7)	
Bumper to ground (rear at curb mass (wt.))	H105	354 (14.0)	
Angle of approach (degrees)	H106	19.1°	
Angle of departure (degrees)	H107	20.9°	
Ramp breakover angle (degrees)	H147	14.5°	
Rear axle differential to ground	H153	297 (11.7)	
Min. run : ground clearance	156	141 (5.6)	
Location of min. run grd. clear.		Front Suspension	

* All vehicle height and ground clearances are made at the Manufacturer's Design Load Weight, unless otherwise specified.

** All Vehicle Height And Ground Clearances Are Made Using EPA Loaded Vehicle Weight, Loading Condition.

EPA LOADED VEHICLE WEIGHT Is The Base Vehicle Weight Plus All Coolant And Fluids Necessary For Operation Plus 100% Of The Fuel Capacity, Plus The Weight Of All Options And Accessories Which Weigh Three Pounds Or More And Which Are Sold On At Least 33% Of The Car Line, Plus Two Occupants.

Passenger Car

METRIC (U.S. Customary)

Car and Body Dimensions See Key Sheets for definitions

Body Type	SAE Ref. No.	2-DOOR HATCHBACK COUPE 1XX08	4-DOOR HATCHBACK SEDAN 1XX68

Front Compartment

Sg RP front, "X" coordinate	L31	1138 (44.8)	
Effective head room	H61	968 (38.1)	
Max. eff. leg room (accelerator)	L34	1073 (42.2)	
Sg RP (front to heel)	H30	257 (10.1)	
Design H-point front travel	L17	192 (7.6)	
Shoulder room	W3	1428 (56.2)	1421 (55.9)
Hip room	W5	1400 (55.1)	
** Upper body opening to ground	H50	1243 (48.9)	
Steering wheel angle	H18	22.0°	
Back angle	L40	26.0°	

Rear Compartment

Sg RP Point couple distance	L50	786 (30.9)	
Effective head room	H63	958 (37.7)	957 (37.7)
Min. effective leg room	L51	880 (34.6)	904 (35.6)
Sg RP (second to heel)	H31	259 (10.2)	261 (10.3)
Knee clearance	L48	10 (0.4)	25 (1.0)
Compartment room	L3	677 (26.7)	691 (27.2)
Shoulder room	W4	1428 (56.2)	1430 (56.3)
Hip room	W6	1366 (53.8)	1397 (55.0)
** Upper body opening to ground	H51	--	1240 (48.8)
Back angle	L41	24.5°	

Luggage Compartment

Usable luggage capacity (L (cu. ft.))	V1	--	--
** Litter height	H195	552 (21.7)	

Interior Volumes (EPA Classification)

Vehicle class		Mid-Size	
Interior volume index (cu. ft.)		94.7	95.7
Trunk cargo index (cu. ft.)		19.4	

All linear dimensions are in millimeters (inches)

** EPA Loaded Vehicle Weight, Loading Conditions

All Interior Dimensions Are Measured With The Seating Reference Point (SgRP) _____ mm
(1 Seat Adjuster Notch) Forward Of Rearmost Seat Position.

Torrance, CA 90503 # PV118E

MVMA Specifications Form

Passenger Car

METRIC (U.S. Customary)

Car and Body Dimensions See Key Sheets for definitions

Car Line CITATION II
 Model Year 1985 Issued 7-84 Revised (●) _____

Body Type

SAE Ref. No.	2-DOOR HATCHBACK COUPE 1XX08	4-DOOR HATCHBACK SEDAN 1XX68
--------------------	------------------------------------	------------------------------------

Station Wagon - Third Seat

Shoulder room	W85	
Hip room	W86	
Effective leg room	L86	
Effective head room	H86	NOT APPLICABLE
Effective T-point head room	H89	NOT APPLICABLE
Seat facing direction	SD1	
Back angle	L88	

Station Wagon - Cargo Space

Cargo length (open front)	L200	
Cargo length (open second)	L201	
Cargo length (closed front)	L202	
Cargo length (closed second)	L203	
Cargo length at belt (front)	L204	
Cargo length at belt (second)	L205	
Cargo width (wheelhouse)	W201	NOT APPLICABLE
Rear opening width at floor	W203	NOT APPLICABLE
Opening width at belt	W204	
Max. rear opening width above belt	W205	
Cargo height	H201	
Rear opening height	H202	
Tailgate to ground height	H250	
Front seat back to load floor height	H197	
Cargo volume index [m ³ (ft. ³)]	V2	
Hidden cargo volume [m ³ (ft. ³)]	V4	
Cargo volume, index-rear of 2-seat	V10	

Hatchback - Cargo Space

Front seat back to load floor height	H197	501 (19.7)	504 (19.8)
Cargo length at front seat back height	L208	1266 (49.8)	1263 (49.7)
Cargo length at floor (front)	L209	1606 (63.2)	
Cargo volume index [m ³ (ft. ³)]	V3	1027 (36.3)	1034 (36.5)
Hidden cargo volume [m ³ (ft. ³)]	V4	--	
Cargo volume index-rear of 2-seat	V11	549 (19.4)	

Aerodynamics*

Wheel lip to ground, front	
Wheel lip to ground, rear	
Frontal area [m ² (ft. ²)]	
Drag coefficient (Cd)	

* Describe measurement method.

Passenger Car
METRIC (U.S. Customary)

Model Year 1985 Issued 7-84 Revised (#) 9-84

Body Type	2-DOOR	4-DOOR
	HATCHBACK COUPE, 1XX08	HATCHBACK SEDAN 1XX68

Vehicle Fiducial Marks

Fiducial Mark Number*	Define Coordinate Location
Front	X - Fiducial mark to vertical base grid line - front, measured horizontally from base grid line to the front fiducial mark located on top of front seat adjuster mounting bolt.
	Y - Fiducial mark to centerline of car - front, width measurement made from centerline of car to the fiducial mark located on top of the front seat adjuster mounting bolt.
	Z - Fiducial mark to horizontal base grid line - front, measured vertically from base grid line to front fiducial mark located on top of the front seat adjuster mounting bolt.
Rear	X - Fiducial mark to vertical base grid line - rear, measured horizontally from the base grid line to rear fiducial mark located on the rail (compartment pan - longitudinal).
	Y - Fiducial mark to centerline of car - rear, width measurement made from centerline of car to fiducial mark located on the rail (compartment pan - longitudinal).
	Z - Fiducial mark to horizontal base grid line - rear, measured vertically from base grid line to rear fiducial mark located on the rail (compartment pan - longitudinal).
Front	W2* 563 (22.2)
	L54 770 (30.3)*
	H81 58 (2.3)#
	H161 306 (12.0)
	** H163 284 (11.2)
Rear	W22 489 (19.3)
	L55 3016 (118.7)*
	H82 186 (7.3)#
	H162 436 (17.2)
	** H164 410 (16.1)
* Vertical Base Grid 2000 mm Line. # Horizontal Base Grid 200 mm Line.	

* Reference - SAE Recommended Practice, J1122a, Motor Vehicle Fiducial Marks - September, 1973.
 All linear dimensions are in millimeters (inches).

** EPA Loaded Vehicle Weight, Loading Conditions

MVMA Specifications Form
Passenger Car
METRIC (U.S. Customary)

Car Line CITATION II
 Model Year 1985 Issued 7-84 Revised (●) _____

Body Type	SAE Ref. No.	2-DOOR HATCHBACK COUPE 1XX08	4-DOOR HATCHBACK SEDAN 1XX68

Lamps and Headlamp Shape*

Height above ground to center of bulb or marker	Headlamp (H127)	Highest**	659 (26.0)
		Lowest	--
	Taillamp (H128)	Highest**	644 (25.4)
		Lowest	--
	Sidemarker	Front	608 (24.0)
		Rear	645 (25.4)
Distance from C.L. of car to center of bulb	Headlamp	Inside	--
		Outside**	615.0 (24.2)
	Taillamp	Inside	--
		Outside**	690.0 (27.2)
	Directional	Front	412.0 (16.2)
		Rear	690.0 (27.2)
Lamp shape			Rectangular

* Measured at curb mass (weight).
 ** If single lamps are used enter here.

Passenger Car

Model Year 1985 issued 7-84 Revised (●)

METRIC (U.S. Customary)

Optional Equipment Differential Mass (weight)*

Equipment	MASS, kg. (weight, lb.)			Remarks
	Front	Rear	Total	
Guards-Door Edge-Bright (Not available with RPO-Z18, Z19.) RPO-B93	.2 (0.4)	0 (0)	.2 (0.4)	All models
Washer and Wiper Windshield-Intermittent RPO-CD4	.2 (0.4)	0 (0)	.2 (0.4)	All models
Defogger-Rear Window Electric RPO-C49	0 (0)	.6 (1.3)	.6 (1.3)	All models
Air Conditioning (Manual Control) Includes K73 Delcotron	24.6 (54.2)	1.6 (3.5)	26.2 (57.7)	All models with RPO-LR8 Engine
-Requires Power Steering RPO-N41	22.2 (48.9)	1.6 (3.5)	23.8 (52.4)	Model 1XX68 with RPO-LE2 Engine, and RPO-M19, 4-Speed Manual Trans
-Requires Power Brakes RPO-J50 RPO-C60	24.2 (53.3)	1.6 (3.5)	25.8 (56.8)	Model 1XX08 with RPO-LE2 Engine and RPO-M19, 4-Speed Manual Transmission.
	22.4 (49.4)	1.6 (3.5)	24.0 (52.9)	Model 1XX68 with RPO-LE2 Engine and RPO-MD9 Automatic Transmission
	24.0 (52.9)	1.6 (3.5)	25.6 (56.4)	Model 1XX08 with RPO-LE2 Engine and RPO-MD9 Automatic Trans
	24.6 (54.2)	1.6 (3.5)	26.2 (57.7)	All models with RPO-LB6 Engine and RPO-MX6, 4-Speed Manual Trans.
	25.0 (55.1)	1.6 (3.5)	26.6 (58.6)	All models with RPO-LB6 Engine and RPO-MD9 Automatic Transmission
Mirror-Remote Control Outside Rr View (LH painted black) RPO-D33	.2 (0.4)	0 (0)	.2 (0.4)	All models
Mirrors-Outside Rear View-Sport LH Remote, RH Convex Manual RPO-D35	.8 (1.8)	.4 (0.9)	1.2 (2.7)	All models
Console-Frt Compartment Floor, Requires RPO AR9 Reclining Bucket Seat RPO-D55	1.4 (3.1)	1.2 (2.6)	2.6 (5.7)	All models with 4-Speed Manual Trai
	2.2 (4.8)	2.2 (4.8)	4.4 (9.6)	All models with Automatic Trans.

*Also see Engine - General Section for dressed engine mass (weight).

MVMA Specifications Form Passenger Car

Car Line CITATION II
Model Year 1985 Issued 7-84 Revised (e) _____

METRIC (U.S. Customary)

Equipment	Optional Equipment Differential Mass (weight)*			Remarks
	MASS. kg. (weight, lb.)			
	Front	Rear	Total	
Sport Suspension	2.8	1.6	4.4	Model 1XX08 with RPO-Z19
RPO-F41	(6.2)	(3.5)	(9.7)	Sport Equipment Package
	2.8	0	2.8	All models without RPO-Z19
	(6.2)	(0)	(6.2)	Sport Equipment Package
Brakes-Vacuum Power	3.2	.4	3.6	All except with RPO-LB6 Engine
-Required with RPO-LE2, LB6 or RPO-C60, RPO-J50	(7.0)	(0.9)	(7.9)	
	3.2	.4	3.6	All with RPO-LB6
	(7.0)	(0.9)	(7.9)	
Electronic Speed Control with Resume	2.8	0	2.8	All models
-Available only with RPO-J50 Power Brakes RPO-K34	(6.2)	(0)	(6.2)	
Engine 2.8 Liter 2-BBL (173 C.I.D.) V-6	28.6	-.4	28.2	All models
-Requires RPO-J50 Power Brakes RPO-LE2	(63.0)	(-0.9)	(62.1)	
Engine 2.8 Liter MFI (173 C.I.D.) V-6	8.0	3.0	41.0	All models
-Requires RPO-J50 Power Brakes RPO-LB6	(83.8)	(6.6)	(90.4)	
Automatic Transmission	19.8	.6	20.4	All models with RPO-LR8, I-4 Engine
-Merchandising Option for RPO-MD9 RPO-MX1	(43.6)	(1.3)	(44.9)	
	20.2	.4	20.6	All models with RPO-LE2, V-6 Engine
	(44.5)	(0.9)	(45.4)	
	18.0	.4	18.4	All models with RPO-LB6, V-6 Engine
	(39.7)	(0.9)	(40.6)	
Sport Steering Wheel	.2	.2	.4	All models
RPO-NK3	(0.4)	(0.4)	(0.8)	
Wheel-Tilt Steering	.6	.6	1.2	All models
-Comfortilt RPO-N33	(1.3)	(1.3)	(2.6)	
Steering-Power	9.8	.2	10.0	All models
-Required with RPO-C60 Air Cond. RPO-N41	(21.6)	(0.4)	(22.0)	

*Also see Engine - General Section for dressed engine mass (weight).

Vehicle Specifications Form
Passenger Car
 METRIC (U.S. Customary)

Exterior Car And Body Dimensions – Key Sheet

Exterior Width

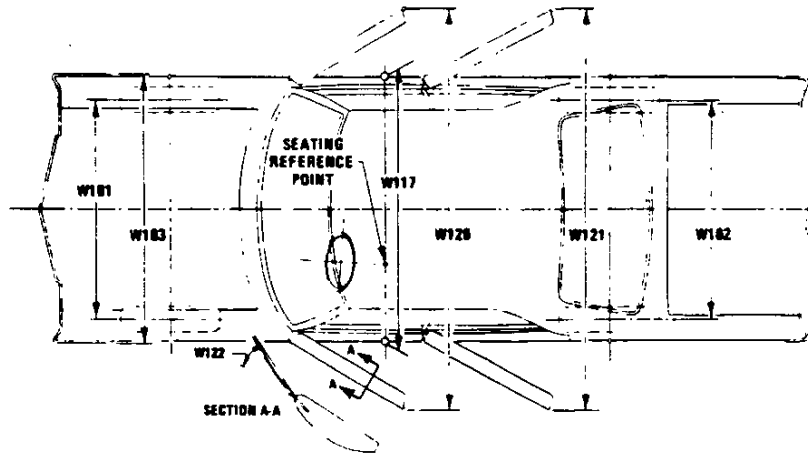

Exterior Length & Height

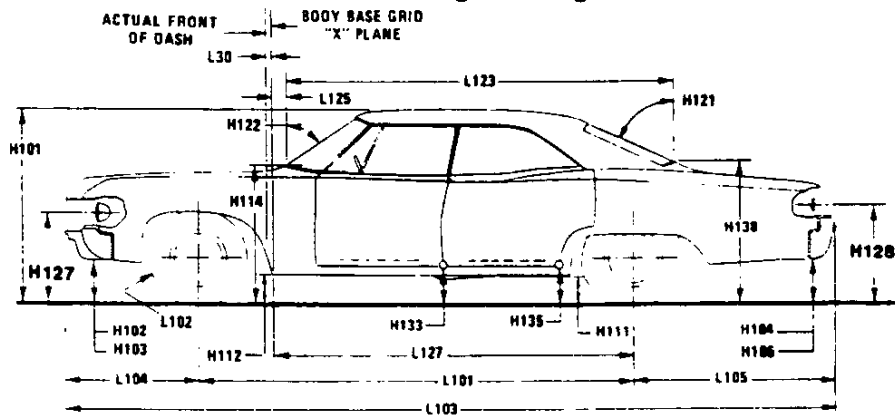

Exterior Ground Clearance

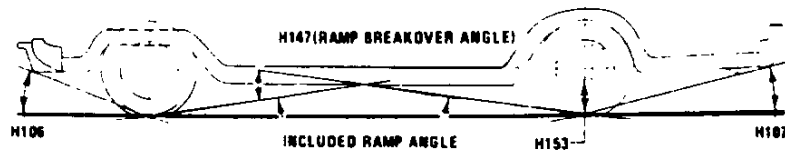

MVMA Specifications Form

Passenger Car

METRIC (U.S. Customary)

Interior Car And Body Dimensions - Key Sheet

Front Compartment

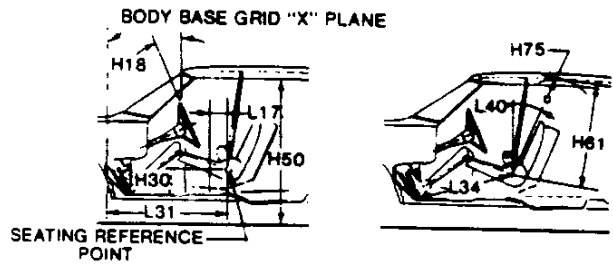

Rear Compartment

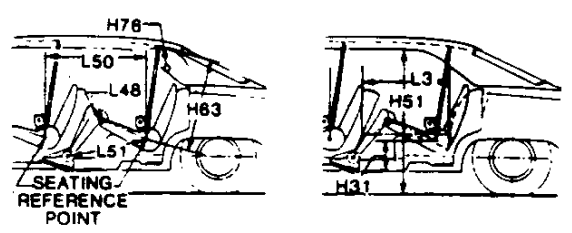

Third Seat

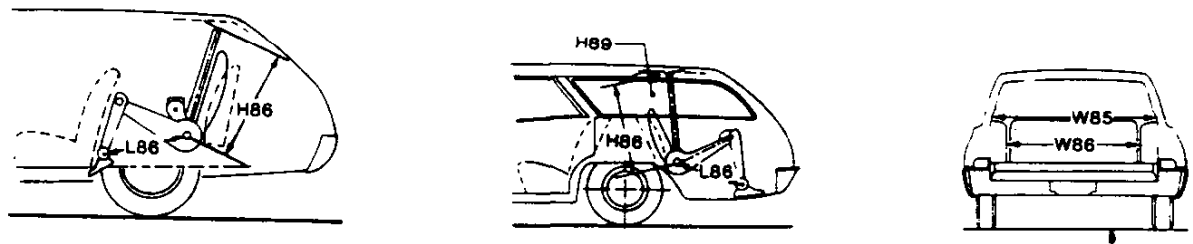

Cargo Space

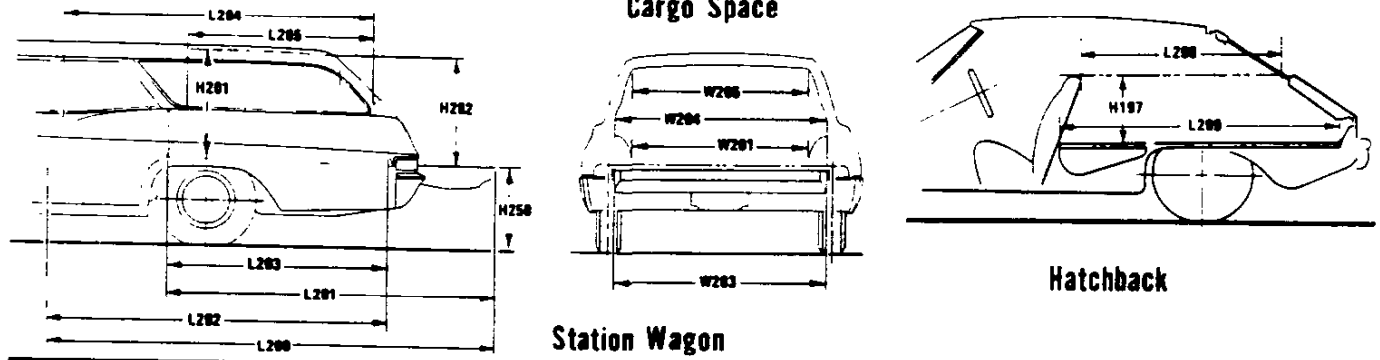

Interior Width

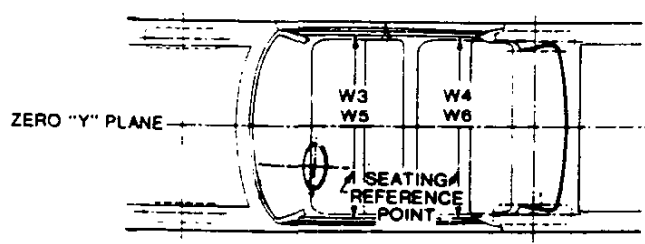

MVMA Specifications Form

Passenger Car

METRIC (U.S. Customary)

Exterior Car And Body Dimensions - Key Sheet

Dimensions Definitions

Seating Reference Point

SEATING REFERENCE POINT means the manufacturer's design reference point which -

- (a) Establishes the rearmost normal design driving or riding position of each designated seating position in a vehicle;
- (b) Has coordinates established relative to the design vehicle structure;
- (c) Simulates the position of the pivot center of the human torso and thigh; and
- (d) Is the reference point employed to position the two dimensional templates described in SAE Recommended Practice J826, "Manikins for Use in Defining Vehicle Seating Accommodations," November, 1962.

Width Dimensions

- W101 TREAD-FRONT. The dimension measured between the tire centerlines at the ground.
- W102 TREAD-REAR. The dimension measured between the tire centerlines at the ground. In case of dual wheels, the dimension will be measured to the centerline of tire and wheel assemblies.
- W103 VEHICLE WIDTH. The maximum dimension measured between the widest point on the vehicle, excluding exterior mirrors, flexible mud flaps, marker lamps, but including bumpers, moldings, sheet metal protrusions or dual wheels, if standard equipment.
- W117 BODY WIDTH AT SgRP-FRONT. The dimension measured laterally between the widest points on the body at the SgRP-front, excluding door handles, applied moldings, or appliques.
- W120 VEHICLE WIDTH-FRONT DOORS OPEN. The dimension measured between the widest point on the front doors in maximum hold-open position.
- W121 VEHICLE WIDTH-REAR DOORS OPEN. The dimension measured between the widest point on the rear doors in maximum hold-open positions. For vehicles with a rear door on only one side, this dimension is to the zero "Y" plane.
- W122 TUMBLE HOME. STRAIGHT SIDE GLASS. The angle measured from a vertical to the outside surface of the front door glass at the SgRP "X" plane.
CURVED SIDE GLASS. The angle measured from a vertical to a chord extending from the upper DLO to the lower DLO at the outside surface of the front door glass at the front SgRP "X" plane.

Length Dimensions

- L30 FRONT OF DASH "X" COORDINATE. A minus (-) dimension indicates actual front of dash in forward of the zero "X" plane.
- L101 WHEELBASE (WB). The dimension measured longitudinally between front and rear wheel centerlines. In case of dual rear axles, the dimension shall be to the midpoint of the centerlines of the rear wheels.
- L102 TIRE SIZE. As specified by the manufacturer.
- L103 VEHICLE LENGTH. The maximum dimension measured longitudinally between the foremost point and the rearmost point on the vehicle, including bumper, bumper guards, tow hooks and/or rub strips, if standard equipment.
- L104 OVERHANG-FRONT. The dimension measured longitudinally from the centerline of the front wheels to the foremost point on the vehicle including bumper, bumper guards, tow hooks and/or rub strips, if standard equipment.
- L105 OVERHANG-REAR. The dimension measured longitudinally from the centerline of the rear wheels; or in the case

- of dual rear axles, the dimension shall be the midpoint of the centerlines of the rear wheels, to the rearmost point on the vehicle, including rear bumpers, bumper guards, tow hooks and rub strips, if standard equipment.
- L123 UPPER STRUCTURE LENGTH. The dimension measured longitudinally from the cowl point to the deck point.
- L127 REAR WHEEL CENTERLINE "X" COORDINATE or in the case of dual rear axles, the coordinate shall be in the midpoint of the distance between the rear axle centerlines.
- L125 COWL POINT "X" COORDINATE.

Height Dimensions

- H101 VEHICLE HEIGHT. The dimension measured vertically from the highest point on the vehicle body to ground.
- H114 COWL POINT TO GROUND. Measured at zero "Y" plane.
- H138 DECK POINT TO GROUND. Measured at zero "Y" plane.
- H112 ROCKER PANEL-FRONT TO GROUND. The dimension measured vertically from the foremost point on the bottom of the rocker panels, excluding flanges, to ground.
- H132 BOTTOM OF DOOR OPEN-FRONT TO GROUND. The dimension measured vertically from the bottom outside corner of the door on the lock pillar side, in maximum hold open position, to ground.
- H111 ROCKER PANEL-REAR TO GROUND. The dimension measured vertically from the bottom of the rocker or quarter panel at the front of the rear wheel opening, excluding flanges, to ground.
- H134 BOTTOM OF DOOR OPEN-REAR TO GROUND. The dimension measured vertically from the bottom outside corner of the door on the lock pillar side, in maximum hold open position, to ground.
- H135 BOTTOM OF DOOR CLOSED-REAR TO GROUND. The dimension measured vertically from the bottom outside corner of the door on the lock pillar side, in maximum closed position, to ground.
- H121 BACKLIGHT SLOPE ANGLE. The angle between the vertical reference line and the surface of backlight at vehicle zero "Y" plane. For curve backlight, the angle is to chord of backlight arc from lower DLO to upper DLO.
- H122 WINDSHIELD SLOPE ANGLE. The angle between vertical reference line and a chord of the windshield running from the lower DLO to the upper DLO at the vehicle zero "Y" plane. In the case of wrap over glass, angle to be measured will be formed by a chord 457 (18.0 in.) long drawn from the lower DLO to the intersecting point on the windshield.
- H127 HEADLAMP TO GROUND-CURB MASS (WT.). The dimension measured vertically from the centerline of the lowest headlamp lens to ground.
- H128 TAILLAMP TO GROUND-CURB MASS (WT.). The dimension measured vertically from the centerline of the upper bulb to ground.

Ground Clearance Dimensions

- H102 FRONT BUMPER TO GROUND. The minimum dimension measured vertically from the lowest point on the front bumper to ground, including bumper guards, if standard equipment.
- H103 FRONT BUMPER TO GROUND CURB MASS (WT.). Measured in the same manner as H104.
- H104 REAR BUMPER TO GROUND. The minimum dimension measured vertically from the lowest point on the rear bumper to ground, including bumper guards, if standard equipment.
- H105 REAR BUMPER TO GROUND - CURB MASS (WT.). Measured in the same manner as H104.

MVMA Specifications Form

Passenger Car

METRIC (U.S. Customary)

Interior Car And Body Dimensions - Key Sheet

Dimensions Definitions

- H106 ANGLE OF APPROACH. The angle measured between a line tangent to the front tire static loaded radius and the initial point of structural interference forward of the front tire to ground. The limiting structural component shall be designated.
- H107 ANGLE OF DEPARTURE. The angle measured between a line tangent to the rear tire static loaded radius and the initial point of structural interference rearward of the rear tire to ground. The limiting component shall be designated.
- H147 REAR BREAKOVER ANGLE. The angle measured between two lines tangent to the front and rear tire static loaded radius and intersecting at a point on the underside of the vehicle which defines the largest ramp over which the vehicle can roll.
- H153 REAR AXLE DIFFERENTIAL TO GROUND. The minimum dimension measured from the rear axle differential to ground.
- H156 MINIMUM RUNNING GROUND CLEARANCE. The minimum dimension measured from the sprung vehicle to ground. Specify location.

Front Compartment Dimensions

- PD1 PASSENGER DISTRIBUTION-FRONT.
L31 SgRP-FRONT "X" COORDINATED.
- H61 EFFECTIVE HEAD ROOM-FRONT. The dimension measured along a line 8 deg. rear of vertical from the SgRP-front to the headlining plus 102 mm (4.0 in.).
- H75 EFFECTIVE T-POINT HEAD ROOM-FRONT. The minimum radius from the T-point to the headlining plus 762 mm (30 in.).
- L34 MAXIMUM EFFECTIVE LEG ROOM-ACCELERATOR. The dimension measured along a line from the ankle pivot center to the SgRP-front plus 254 mm (10.0 in.) measured with right foot on the undepressed accelerator pedal. For vehicles with SgRP to heel (H30) greater than 18 in., the accelerator pedal may be depressed as specified by the manufacturer. If the accelerator is depressed, the manufacturer shall place foot flat on pedal and note the depression of the pedal.
- H30 SgRP-FRONT TO HEEL. The dimension measured vertically from the SgRP-front to the accelerator heel point.
- L17 DESIGN H-POINT-FRONT TRAVEL. The dimension measured horizontally between the design H-point-front in the fore-and-aft and rearmost seat trace positions.
- W3 SHOULDER ROOM-FRONT. The minimum dimension measured laterally between the trimmed surfaces on the "X" plane through the SgRP-front within the belt line and 254 mm (10.0 in.) above the SgRP-front.
- W5 HIP ROOM-FRONT. The minimum dimension measured laterally between the trimmed surfaces on the "X" plane through the SgRP-front within 25 mm (1.0 in.) below and 76 mm (3.0 in.) above the SgRP-front and 76 mm (3.0 in.) fore and aft the SgRP-front.
- H50 UPPER BODY OPENING TO GROUND-FRONT. The dimension measured vertically from the trimmed body opening to the ground on the SgRP-front "X" plane.
- H18 STEERING WHEEL ANGLE. The angle measured from a vertical to the surface plane of the steering wheel.
BACK ANGLE-FRONT. The angle measured between a vertical line through the SgRP-front and the torso line. If the seatback is adjustable, use the normal driving and riding position specified by the manufacturer.
- L40 BACK ANGLE-FRONT. The angle measured between a vertical line through the SgRP-front and the torso line. If the seatback is adjustable, use the normal driving and riding position specified by the manufacturer.

Rear Compartment Dimensions

- PD2 PASSENGER DISTRIBUTION-SECOND.
L50 SgRP DOUBLE DISTANCE. The dimension measured horizontally from the driver SgRP-front to the SgRP-second.

- H63 EFFECTIVE HEAD ROOM-SECOND. The dimension measured along a line 8 deg. rear of vertical from the SgRP to the headlining, plus 102 mm (4.0 in.).
- H76 EFFECTIVE T-POINT HEAD ROOM-SECOND. Measured in the same manner as H75.
- L51 MINIMUM EFFECTIVE LEG ROOM-SECOND. The dimension measured along a line from the ankle pivot center to the SgRP-second plus 254 mm (10.0 in.).
- H31 SgRP-SECOND TO HEEL. The dimension measured vertically from the SgRP-second to the two dimensional device heel point on the depressed floor covering.
- L48 KNEE CLEARANCE-SECOND. The minimum dimension measured from the knee pivot to the back of front seatback minus 51 mm (2.0 in.).
- L3 COMPARTMENT ROOM-SECOND. The dimension measured horizontally from the back of front seat to the front of the second seatback at a height tangent to the top of the second seat cushion.
- W4 SHOULDER ROOM-SECOND. The minimum dimension measured laterally between trimmed surfaces on the "X" plane through the SgRP-second within 254-406 mm (10.0-16.0 in.) above the SgRP-second.
- W6 HIP ROOM-SECOND. Measured in the same manner as W5.
- H51 UPPER BODY OPENING TO GROUND-SECOND. The dimension measured vertically from the trimmed body opening to the ground on the "X" plane 330 mm (13.0 in.) forward of the SgRP-second.
- L-41 Same as L-40.

Luggage Compartment Dimensions

- V1 USABLE LUGGAGE CAPACITY-Total of volumes of individual pieces of standard luggage set plus H-boxes stowed in the luggage compartment in accordance with the procedure described in paragraph 8.2 of SAE-J1100a.
- H195 LIFTOVER HEIGHT. The dimension measured vertically from the luggage compartment lower opening at the zero "Y" plane to ground.

Interior Volumes (EPA Classification)

The Interior Volume Index is listed for each body style except two seaters. The interior volume index estimates the space in a car. It is based on four measurements - head room, shoulder room, hip room, and leg room - for the front and rear seats, plus trunk capacity. The interior volume index is an estimate of the size of the passenger compartment.

The Trunk/Cargo Index is an estimate of the size of the trunk/cargo space. In station wagons and hatchbacks, it is an estimate of the space behind the second seat.

Station Wagon - Third Seat Dimensions

- PD3 PASSENGER DIRECTION-THIRD.
W85 SHOULDER ROOM-THIRD. Measured in the same manner as W5.
- W86 HIP ROOM-THIRD. Measured in the same manner as W5.
L86 EFFECTIVE LEG ROOM-THIRD. The dimension measured along a line from the ankle pivot center to the SgRP-third plus 254 mm (10.0 in.).
- H86 EFFECTIVE HEAD ROOM-THIRD. The dimension, measured along a line 8 deg. from the SgRP-third to the headlining rear of vertical plus a constant of 102 mm (4.0 in.).
- H89 EFFECTIVE T-POINT HEAD ROOM-THIRD. Measured in the same manner as H75.
- L-88 Same as L-40.

Station Wagon - Cargo Space Dimensions

- L200 CARGO LENGTH-OPEN-FRONT. The minimum dimension measured longitudinally from the back of the front

Passenger Car

METRIC (U.S. Customary)

Interior Car And Body Dimensions - Key Sheet

Dimensions Definitions

Station wagon - Cargo Space Dimensions (con't.)

- seatback at the height of the undepressed floor covering to the rearmost point on the undepressed floor covering on the open tailgate or cargo surface if the rear closure is a conventional door type tailgate, at the zero "Y" plane.
- L201 CARGO LENGTH-OPEN-SECOND. The dimension measured longitudinally from the back of the second seatback at the height of the undepressed floor covering on the open tailgate or cargo floor surface if the rear closure is a conventional door type tailgate, at the zero "Y" plane.
- L202 CARGO LENGTH-CLOSED-FRONT. The minimum dimension measured horizontally from the back of the front seat at the height of the undepressed floor covering to the rearmost point on the undepressed floor covering on the closed tailgate or taildoor for station wagons, trucks and mpv's at the zero "Y" plane.
- L203 CARGO LENGTH-CLOSED-SECOND. The dimension measured horizontally from the back of the second seat at the height of the undepressed floor covering to the rearmost point on the undepressed floor covering on the closed tailgate or taildoor for station wagons, trucks and mpv's at the zero "Y" plane.
- L204 CARGO LENGTH AT BELT-FRONT. The minimum dimension measured horizontally from the back of the front seatback at the seatback top to the foremost normal surface of the closed tailgate or inside surface of the cab back panel at the height of the belt, on the zero "Y" plane.
- L205 CARGO LENGTH AT BELT-SECOND. The minimum dimension measured horizontally from the back of the second seatback at the seatback top to the foremost normal surface of the closed tailgate at the height of the belt, on the zero "Y" plane.
- W201 CARGO WIDTH-WHEELHOUSE. The minimum dimension measured laterally between the trimmed wheelhouseings at floor level. For any vehicle not trimmed, measure the sheet metal.
- W203 REAR OPENING WIDTH AT FLOOR. The minimum dimension measured laterally between the limiting interferences of the rear door opening at floor level.
- W204 REAR OPENING WIDTH AT BELT. The minimum dimension measured laterally between the limiting interferences of the rear opening at belt height or top of pick up box.
- W205 REAR OPENING WIDTH ABOVE BELT. The minimum dimension measured laterally between the limiting interferences of the rear opening above the belt height.
- H201 CARGO HEIGHT. The dimension measured vertically from the top of the undepressed floor covering to the headlining at the rear wheel "X" coordinated on the zero "Y" plane.
- H202 REAR OPENING HEIGHT. The dimension measured vertically from the top of the undepressed floor covering to the upper trimmed opening on the zero "Y" plane with rear door fully open.
- H250 TAILGATE TO GROUND (CURB MASS WT.). The dimension measured vertically from the top of the undepressed floor covering on the lowered tailgate to ground on the zero "Y" plane.
- V2 STATION WAGON
Measured in inches:
$$\frac{W4 \times H201 \times L204}{1728} = \text{ft.}^3$$

Measured in mm:
$$\frac{W4 \times H201 \times L204}{10^9} = \text{m}^3 \text{ (cubic meter)}$$
- V4 HIDDEN CARGO VOLUME. As specified by the manufacturer.

V10 STATION WAGON (REAR OF SECOND SEAT)

Measured in inches:
$$\frac{W4 \times H201 \times L205}{1728} = \text{ft.}^3$$

Measured in mm:
$$\frac{W4 \times H201 \times L205}{10^9} = \text{liters}$$

Hatchback - Cargo Space Dimensions

All hatchback cargo dimensions are to be taken with the front in full down and rear position, and the rear seat folded down. Hatchback door is in the closed position. (For electrically adj. seats, see the manufacturer's specifications for Design "H" Poi

H197 FRONT SEATBACK TO LOAD HEIGHT. The dimension measured vertically from the horizontal tangent to the top of the seatback to the undepressed floor covering.

H198 SECOND SEATBACK TO LOAD FLOOR HEIGHT. The vertical dimension from the horizontal tangent to the top of the seatback to undepressed floor covering at zero "Y" plane.

L208 CARGO LENGTH AT FRONT SEATBACK HEIGHT. The minimum horizontal dimension from the "X" plane tangent to the rearmost surface of the driver's seatback to the side limiting interference of the hatchback door on the zero "Y" plane.

L209 CARGO LENGTH AT FLOOR-FRONT-HATCHBACK. The minimum horizontal dimension measured at level from the rear of the front seatback to the side limiting interference of the hatchback door on the zero "Y" plane.

L210 CARGO LENGTH AT SECOND SEATBACK HEIGHT. The horizontal dimension from the plane tangent to rearmost surface of second seatback to the load floor which is stowed at least one half of the dimension height above the rear load floor, to the rear inside limiting interference on the zero "Y" plane.

L211 CARGO LENGTH AT FLOOR-HATCHBACK-SECOND SEATBACK. The horizontal dimension at floor level from the rear of the second seatback or load floor panel to the normal limiting interference of the hatchback door on the vehicle zero "Y" plane.

V3 HATCHBACK.
Measured in inches:
$$\frac{(L208 + L209) \times W4 \times H197}{1728} = \text{ft.}^3$$

Measured in mm:
$$\frac{(L208 + L209) \times W4 \times H197}{10^9} = \text{m}^3 \text{ (cubic meter)}$$

V11 HATCHBACK (REAR OF SECOND SEAT)

Measured in inches:
$$\frac{W4 \times H198 \times \frac{(L210 + L211)}{2}}{1728} = \text{ft.}^3$$

Measured in mm:
$$\frac{W4 \times H198 \times \frac{(L210 + L211)}{2}}{10^9} = \text{liters}$$

MVMA Specifications Form

Passenger Car

METRIC (U.S. Customary)

Index

Subject	Page No.	Subject	Page No.
Aerodynamics	22	Kingpin (Steering Axis)	4
Alternator	16	Lamps and Headlamp Shape	24
Automatic Transmission	9	Legroom	21, 22
Axis, Steering	14	Lengths - Car and Body	20
Axle, Rear	10	Leveling, Suspension	11
Axle Shafts	10	Lifters, Valve	4
Battery	16	Linings - Clutch, Brake	8, 12
Brakes - Parking, Service	12, 13	Lubrication - Transmission	8, 9
Camber	15	Luggage Compartment	21
Camshaft	3	Mass	25, 26
Capacities		Models	1
Cooling System	5	Motor Starting	16
Fuel Tank	6	Muffler	7
Lubricants		Passenger Capacity	1
Engine Crankcase	4	Passenger Mass Distribution	25
Transmission	9	Pistons	3
Rear Axle	10	Power Brakes	12
Car Models	1	Power, Engine	2
Car and Body Dimensions		Power Steering	14
Width	20	Power Teams	2
Length	20	Propeller Shaft, Universal Joints	10
Height	20	Pumps - Fuel	6
Ground Clearance	20	Water	5
Front Compartment	21	Radiator - Cap, Hoses	5
Rear Compartment	21	Ratios - Axle	2, 9
Luggage Compartment	21	Compression	2
Station Wagon - Third Seat	22	Steering	14
Station Wagon - Cargo Space	22	Transmission	2, 8, 9
Hatchback - Cargo Space	22	Rear Axle	2, 9, 10
Carburetor	2, 6	Regulator - Generator	16
Caster	15	Restraint System	18
Choke, Automatic	6	Rims	13
Clutch - Pedal Operated	8	Rods - Connecting	4
Coil, Ignition	16	Seats	17
Connecting Rods	4	Shock Absorbers, Front & Rear	11
Convenience Equipment	19	Spark Plugs	16
Cooling System	5	Speedometer	15
Crankshaft	4	Springs - Front & Rear Suspension	11
Cylinders and Cylinder Head	3	Stabilizer (Sway Bar) - Front & Rear	11
Diesel Information	4	Starting System	16
Dimension Definitions		Steering	14
Key Sheet - Exterior	27, 29	Suppression - Ignition, Radio	16
Key Sheet - Interior	28, 30, 31	Suspension - Front & Rear	11
Electrical System	15, 16	Tail Pipe	7
Emission Controls	7	Theft Protection	19
Engine - General		Thermostat, Cooling	5
Bore, Stroke, Type	3	Tires	13
Compression Ratio	2	Toe-in	15
Displacement	2, 3	Torque Converter	9
Firing Order, Cylinder Numbering	3	Torque - Engine	2
General Information, Power & Torque	2	Transaxle	9
Identification Number Location	17	Transmission - Types	2, 8, 9
Power Teams	2	Transmission - Automatic	2, 8, 9
Exhaust System	7	Transmission - Manual	2, 8, 9
Equipment Availability, Convenience	19	Transmission - Ratios	2, 9
Fan, Cooling	5	Tread	20
Federal Marks	23	Trunk Cargo Load	1
Filters - Engine Oil, Fuel System	4	Trunk Luggage Capacity	21
Frame	17	Turning Diameter	4
Front Suspension	11	Unitized Construction	17
Front Wheel Drive Unit	10	Universal Joints, Propeller Shaft	10
Fuel System	6	Valve System	4
Fuel Injection	6	Vehicle Identification Number	17
Fuel Tank	6	Voltage Regulator	16
Generator and Regulator	16	Water Pump	5
Glass	17	Weights	25, 26
Headroom - Body	21, 22	Wheel Alignment	15
Heights - Car and Body	20	Wheelbase	20
Horns	15	Wheels & Tires	13
Horsepower - Brake	2	Wheel Spindle	14
Ignition System	16	Widths - Car and Body	20
Inflation - Tires	13	Windshield	7
Instruments	15	Windshield Wiper and Washer	15