

ORIGINAL

AUTOMOBILE MANUFACTURERS ASSOCIATION
CONSOLIDATED SPECIFICATION QUESTIONNAIRE

MAKE OF CAR:	CHEVROLET	MODEL NAME	SYMBOL
COMPANY:	CHEVROLET DIVISION GENERAL MOTORS CORP., GENERAL MOTORS BLDG., DETROIT 2, MICHIGAN	CORVETTE	2934
MODEL YEAR:	1953	DATE	November 15, 1953

TABLE OF CONTENTS

General Specifications.....	1	Frame.....	16
Engine.....	2	Front Suspension.....	16
Electrical.....	8	Steering.....	17
Drive Units.....	12	Rear Suspension.....	18
Brakes.....	15	Body.....	19
Index.....	24		

- NOTES: 1. The specifications set forth herein are those in effect at the date of compilation and are subject to change without notice.
2. All specifications are standard for the models under which they are listed unless otherwise indicated.
3. All dimensions are nominal engineering dimensions unless otherwise indicated.
4. Unless otherwise indicated, specifications apply to 5 or 6 passenger, 4-door sedan or equivalent.

GENERAL SPECIFICATIONS

Model	CORVETTE	
Wheelbase	102"	
Tread	Front	57"
	Rear	59.00"
Maximum Overall Dimensions	Length (L-103)	167.00"
	Width (W-103)	72.24
	Height (H-101)	48.50 Over W/S (Top Down)
Steering ratio—overall	16:1	
Turning diameter (curb to curb)	38'	
Shipping weight*	2705 Without Radio & Heater	
Transmission— (Specify standard, optional, not avail.)	Conventional	N.A.
	Overdrive	N.A.
	Automatic	Powerglide
Axle ratio	Conventional	--
	Overdrive	--
	Automatic	3.55:1
Tire size	6.70 x 15-4 Ply Rating	
Engine	Type	In Line
	No. of cylinders	6
	Valve arrangement	In Head
	Bore and stroke	3-9/16 x 3-15/16
	Piston displacement, cu. in.	235.5
	Standard compression ratio	8.0:1
	Maximum bhp at engine rpm	150 @ 4200
Maximum torque at rpm	223 @ 2400	

* Standard car weight, not including gas and water.

AMA Consolidated Specification Questionnaire

MAKE OF CAR CHEVROLET MODEL YEAR 1953

MODEL CORVETTE

ENGINE—GENERAL

Type	V, In-line, other Angle of V	In Line --	
No. of cylinders		6	
Valve arrangement		In Head	
Bore and stroke		3-9/16 x 3-15/16	
Piston displacement, cu. in.		235.5	
Numbering system (front to rear)	L Bank	--	
	R Bank	--	
Firing order		1-5-3-6-2-4	
Compression ratio	Standard Head	8.0:1	
	Optional Head	--	
Cylinders	Head Material	Standard Cast Alloy Iron	
		Optional	--
	Sleeve—Wet, dry, other, none		None
Number of mounting points	Front	2	
	Rear	1	
Taxable horsepower	(Dia. ² x No. Cyl.) 2.5	30.4	
Advertised net brake horsepower at engine RPM*	Standard head	150 @ 4200	
	Optional head	--	
	With fuel (Octane and method)	Standard Head	89-93
		Optional Head	--
Max. torque (lb. ft. @ RPM)	Standard head	223 @ 2400	
	Optional head	--	
Recommended idle speed (neutral)		475 In Drive	

ENGINE—PISTONS

Material	Cast Alloy Aluminum with steel struts		
Description and finish	Flat head, tin plated, oval, with thermo controlled expansion		
Weight (piston only) oz.	18.88		
Clearance	Top land	.0115 - .0155	
	Skirt	Top	.0006 - .001
		Bottom	--
Ring groove depth	No. 1 ring	.184 - .192	
	No. 2 ring	.184 - .192	
	No. 3 ring	.184 - .192	
	No. 4 ring	--	

*Corrected as defined by SAE Engine Test Code, with the following standard power consuming accessories: Dynamometer exhaust system, no engine fan, generator (not charging).

AMA Consolidated Specification Questionnaire

MAKE OF CAR CHEVROLET MODEL YEAR 1953

MODEL CORVETTE

ENGINE—RINGS

Type (top to bottom)	No. 1 ring comp.	Deep Section Twist	
	No. 2 ring comp.	Deep Section Twist	
	No. 3 oil expander	Wide Slot	
	No. 4 oil or comp.	None	
No. rings above piston pin		3	
Compression	Material	Cast Iron	
	Coating	Top Ring Chrome Plate	Bottom Ring Wear Resistant
	Width	.0930 - .0935	.0930 - .0935
	Gap	.010 - .020	.007 - .017
	Maximum wall thickness	.178	.178
Oil	Material	Cast Iron	
	Coating	None	
	Width	.1860-.1865	
	Gap	.005-.015	
	Maximum wall thickness	.111	
Location of expanders		Oil Ring	

ENGINE—PISTON PINS

Material		Chromium steel (file hard case)	
Length		3.198-3.228	
Diameter		.8660-.8665	
Type	Locked in rod, in piston, floating, etc.		Locked in rod
	Bushing	In rod or piston	None
		Material	None
Clearance	In piston	.00015-.00025	
	In rod	Locked in rod	
Direction offset in piston		Right	

ENGINE—CONNECTING RODS

Material		Drop forged steel	
Weight (oz.)		30.88	
Length (center to center)		6-13/16	
Bearing	Material	Thin Wall, High Lead Babbitt	
	Type (cast-in or removable)	Removable	
	Effective length	.998	
	Clearance	.0007-.0028	
End play		.005-.012	

ENGINE—CRANKSHAFT

Material		Drop forged steel	
Weight (lb.)		78-1/2	

AMA Consolidated Specification Questionnaire

MAKE OF CAR CHEVROLET MODEL YEAR 1953

MODEL CORVETTE

ENGINE—CRANKSHAFT (cont.)

Vibration damper type		Oscillating (rubber floating)	
End thrust taken by bearing (No.)		3	
Crankshaft end play		.0035-.0095	
Main bearing	Material	Steel backed, thin wall babbitt	
	Type (cast-in or removable)	Removable	
	Clearance	.0002-.0028	
	Journal dia. and bearing effective length	No. 1	2.6835-2.6845 x 1-23/64
		No. 2	2.7145-2.7155 x 1.245-1.255
		No. 3	2.7455-2.7465 x 1.247-1.257
		No. 4	2.7765-2.7775 x 2 (a)
		No. 5	--
No. 6	--		
No. 7	--		
Direction offset from cyl. bore		None	
Connecting rod crankpin journal diameter		2.311-2.312	

ENGINE—CAMSHAFT

Material		Cast Iron	
Bearings	Material	Steel backed babbitt	
	Number	4	
	Gear or chain	Gear	
	Crankshaft gear or sprocket material	Steel	
Type of drive	Camshaft gear or sprocket material	Aluminum	
	Timing chain	Make	None
		No. of links	--
		Width	--
		Pitch	--

ENGINE—VALVE SYSTEM

Hydraulic lifters (yes, no)		No
Special provision for valve rotation (intake, exhaust)		No
Rocker ratio		1.477:1
Operating tappet clearance (indicate hot or cold)	Intake	.010" Hot
	Exhaust	.020" Hot
Tappet clearance for timing	Intake	--
	Exhaust	Zero lash #1
Timing marks on fly-wheel, damper, other		Flywheel

(a) - 1-3/4 not including undercut.

AMA Consolidated Specification Questionnaire

MAKE OF CAR CHEVROLET MODEL YEAR 1953

MODEL CORVETTE

ENGINE—VALVE SYSTEM (cont.)

Timing	Intake	Opens (°BTC)	(19° 30')	
		Closes (°ABC)	(14° 30')	
	Exhaust	Opens (°BBC)	59°	
		Closes (°ATC)	5°	
Intake	Material		Silchrome Steel	
	Overall length		6.364-6.394	
	Actual overall head dia.		1.875	
	Angle of seat		30° Valve face, 31° cylinder head	
	Seat insert material		None	
	Stem diameter		.3410-.3417	
	Stem to guide clearance		.001-.0027	
	Lift		.4051	
	Outer spring press. and length	Valve closed (lb. @ in.)	52-58 at 1.88	
		Valve open (lb. @ in.)	145-155 at 1.49	
	Inner spring press. and length	Valve closed (lb. @ in.)	23-27 at 1.81	
		Valve open (lb. @ in.)	54-60 at 1.42	
	Exhaust	Material		Silchrome XCR Steel
		Overall length		4.613-4.643
Actual overall head dia.		1.495-1.505		
Angle of seat		45° Valve face		
Seat insert material		None		
Stem diameter		.3390-.3397		
Stem to guide clearance		.003-.0047		
Lift		.4143		
Outer spring press. and length		Valve closed (lb. @ in.)	52-58 at 1.88	
		Valve open (lb. @ in.)	145-155 at 1.49	
Inner spring press. and length		Valve closed (lb. @ in.)	23-27 at 1.81	
		Valve open (lb. @ in.)	54-60 at 1.42	

ENGINE—LUBRICATION SYSTEM

Type of lubrication (splash, pressure, nozzle)	Main bearings	Pressure
	Connecting rods	Pressure
	Piston pins	Splash
	Camshaft bearings	Pressure
	Tappets	Metered Pressure
	Timing gear or chain	Pressure Spray
	Cylinder walls	Pressure Jet

AMA Consolidated Specification Questionnaire

Page 6

NAME OF CAR CHEVROLET MODEL YEAR 1953

MODEL _____ CORVETTE

ENGINE—LUBRICATION SYSTEM (cont.)

Oil pump type	Gear
Normal oil pressure (lb. @ mph)	45 psi
Oil pressure gage type (electric or mechanical)	Mechanical
Type oil intake (floating, stationary)	Stationary, non-corrosive steel wire mesh screen
Oil filter type (full flow, partial flow)	None
Capacity of crankcase, less filter—refill (qt.)	5
Oil grade recommended (SAE viscosity and temperature range)	Not lower than 32°F - 20W or SAE20 As low as 100°F - 20W As low as -10°F - 10W Below -10°F - 5W
Oil type recommended	Heavy Duty

ENGINE—FUEL SYSTEM

Recommended fuel	Standard head	Premium
	Optional head	None
Fuel tank, capacity (gal.)		17.25
Fuel pump	Type (elec. or mech.)	Mechanical
	Location	Right hand side near front of block
	Pressure range	3-1/2-4-1/2
	Vacuum booster (std., optl., none)	Standard
Carburetor	Make	Carter
	Model number	3706989
	Number used	3
Type	Downdraft, side inlet, other	Side draft
	Single or dual	Single
Intake manifold heat control (manual, auto., none)		None
Automatic choke type (integral, other)		Manual
Air cleaner type	Standard	Air inlet extension and screen assy.
	Optional	None

ENGINE—EXHAUST SYSTEM

Muffler type (reverse flow, straight through)	Straight Through
Exhaust pipe diameter	1.745"
Tail pipe diameter	1.697" inside. See note (a)

(a) - Stainless steel tail pipe extension added to end of tail pipe.

AMA Consolidated Specification Questionnaire

MAKE OF CAR CHEVROLET MODEL YEAR 1953

MODEL _____ CORVETTE

ENGINE—COOLING SYSTEM

Type (pressure system, atmospheric, other)		Pressure	
Radiator cap relief valve press.		See Note (a)	
Circulation thermostat	Type (choke, bypass)	Choke	
	Starts to open at	151°	
Water pump	Type (centrifugal, other)	Centrifugal	
	Number of pumps	1	
	Drive (V-belt, other)	V-belt	
	Bearing type	Permanently lubricated, double row ball bearing	
By-pass recirculation type (internal, external)		Internal	
Radiator core type (cellular, tube and fin)		Cellular	
Cooling system capacity	With heater (qt.)	18.25	
	Without heater (qt.)	17.75	
Water jackets full length of cylinder (yes, no)		Full stroke length	
Water all around cylinder (yes, no)		Yes	
Radiator hose	Lower	Number and type (molded, straight)	2-Molded with steel tube elbow between
		Inside diameter and length	Hose 1-1/2" x 6-1/2" - Tube 1.465" x 6.50"
	Upper	Number and type (molded, straight)	2 - 1-Molded 1-Straight
		Inside diameter and length	Molded 1-1/4" x 12" Straight 1-1/4" x 10.50"
	By-pass	Number and type (molded, straight)	None
		Inside diameter and length	--
Drive belts	Fan	Number used	1
		Angle of V	37° - 44° Wrap molded or cut molded
		Outside length	40"
	Generator	Width	3/8"
		Angle of V	Generator driven by fan belt
		Outside length	--
Fan	Width	--	
	Number of blades and spacing	4 Staggered	
	Diameter	18"	
	Ratio—fan to crankshaft revolutions	.90:1	
Bearing type		On water pump	

(a) - Auxiliary tank relief valve pressure 3-1/2 - 4-1/2 lbs.

AMA Consolidated Specification Questionnaire

Page 8
REV. 7-52

MAKE OF CAR CHEVROLET MODEL YEAR 1953

MODEL CORVETTE

ELECTRICAL—SUPPLY SYSTEM

Battery	Make and Model	Delco 15AA6-W		
	Voltage Rtg. & Plates/cell	6 Volt-15 Plate		
	SAE Designation & Amp Hr. Rtg	TM, 100 Amp. Hrs. @ 20 Hr. Rate		
	Location	Right side under hood		
	Terminal grounded	Negative		
Generator	Make	Delco-Remy		
	Model	1102793		
	Type	2 brush, shunt wound		
	Ratio—Gen. to Cr/s rev.	2.05:1		
Regulator	Make	Delco-Remy		
	Model	1118725		
	Type	Current and voltage control		
	Cutout relay	Closing voltage @ generator rpm	6.4 at 1160	
		Reverse current to open	--	
	Regu-lated	Voltage	7.4	
		Current	45	
	Min. Gen. rpm required	(For max. output) 2250 cold, 2550 hot		
Voltage test con-ditions	Temperature	Operating		
	Load	Run 15 minutes at 8-10 amps.		
	Other	--		

ELECTRICAL—STARTING SYSTEM

Starting motor	Make	Delco-Remy		
	Model	1107109		
	Rotation (drive end view)	Clockwise		
	Engine cranking speed	125		
	Test conditions	Engine at operating temperatures		
	Lock test	Amps	525	
		Volts	3.4	
		Torque (lb. ft.)	11	
	No load test	Amps	65	
		Volts	5.0	
RPM (min.)		5000		
	Switch (solenoid, manual)	Solenoid		
Motor control	Starting procedure	Place selector lever in PARK or NEUTRAL. Pull choke knob out part way or all the way depending on climatic conditions. Turn ignition key to extreme right position to start engine.		

AMA Consolidated Specification Questionnaire

Page 9

MAKE OF CAR CHEVROLET MODEL YEAR 1953

MODEL CORVETTE

ELECTRICAL—STARTING SYSTEM (cont.)

Motor drive	Engagement type		Over-running clutch
	Pinion meshes (front, rear)		Front
	Number of teeth	Pinion	9
		Flywheel	139
Flywheel tooth face width		1/2	

ELECTRICAL—IGNITION SYSTEM

Coil	Make		Delco Remy
	Model		1115394
	Amps	Engine stopped	5.4
Engine idling		3.0	
Distributor	Make		Delco Remy
	Model		1112314
	Spark advance data (at distributor shaft)	Centr. advance start (rpm)	225-375
		Centr. advance max. deg. @ rpm	12°-14° @ 1750 RPM
		Vacuum advance start (in. Hg.)	4.0-6.0
		Vac. adv. (max. deg. @ in. Hg.)	13°-17° @ 10.0-7.5
	Breaker gap (in.)		.013-.018
Cam angle (deg.)		40.5-47.5	
Breaker arm tension (oz.)		19-23	
Timing	C/S deg. @ rpm		2° ATC initial advance
	Mark location		Flywheel
	Cylinder numbering system (see page 2)		Front to rear
Firing order (see page 2)		1-5-3-6-2-4	
Spark plug	Make and model		AC, 44-5 See (a)
	Thread (mm)		14
	Tightening torque (lb. ft.)		20-25
	Gap		.033-.036
Cable	Conductor type		Linen core impregnated with an electrical conducting matl.
	Insulation type		Rubber with neoprene jacket
	Spark plug protector		Neoprene compound

ELECTRICAL—SUPPRESSION

Description	Metal shields for ignition system. Coaxial condenser for primary circuit. Coaxial condensers for generating circuit. Shielded wiring generator to voltage regulator. Non-metallic high tension cables. Shielded neutral safety switch at transmission.
-------------	--

— (a) - AC-43-5COM (optional use for continuous high speed operation.)

AMA Consolidated Specification Questionnaire

MAKE OF CAR CHEVROLET MODEL YEAR 1953

MODEL CORVETTE

ELECTRICAL—INSTRUMENTS AND SWITCHES

Speed-ometer	Make	AC See note (a)
	Trip odometer (yes, no)	No
Charge indicator—type		Ammeter
Temperature indicator—type		Bourdon tube
Oil pressure indicator—type		Bourdon tube
Fuel indicator—type		Electric
Ignition switch	Identify positions in order and circuits controlled	Vertical - Off, unlocked Counter clockwise - Off, locked 1st Position clockwise from vert. - Ignition and Accessories "ON" 2nd Position clockwise from vert. - Ignition, accessories & starter "ON" with spring return to 1st position. (Key removable in all positions)
	Provision for illumination	Yes, bulb at switch
	Location	On instrument panel - right of steering column
	Theft protection type	None
Main lighting switch	Identify positions and lights controlled	Depressed - Off 1st. notch - Instrument panel lights, parking lights 2nd. notch - Instrument panel lights, driving lights Rotate - clockwise to dim and turn off instrument panel lights Counter clockwise to turn on and brighten panel lights
	Locations and lamps controlled	Left hand toe board - High and low beam driving lights. Parking brake handle on - light on. Released - light out. Parking brake alarm light switch on parking brake. Lever housing at rear of instrument panel. Front compartment courtesy lamp switch in door hinge pillars. Door open - light on. Door closed - light out.
	Locations and devices controlled	Directional signal switch in hub of steering mast jacket.
Windshield wiper	Make	Trico
	Type	Vacuum
	Vacuum booster provision	Standard
	Washer provision	Standard
Horn	Type	Vibrator
	Number used	2
	Amp draw (each)	High 17-19. Low 19-21

(a) - AC tachometer with totalizer.

AMA Consolidated Specification Questionnaire

MAKE OF CAR CHEVROLET MODEL YEAR 1953

MODEL CORVETTE

ELECTRICAL—LAMP BULBS

Give quantity used and trade number, e.g., Headlamp 2-4020.
Indicate accessories which are not standard equipment by an asterisk following the number.

Headlamp		Sealed beam unit GM Part No. 193195
Headlamp beam indicator		1-51
Parking light		3-cp filament of 1154 bulb
Tail light		3-cp filament of 1154 bulb
Stop light		21-cp filament of 1154 bulb
Direction indicator	Front	21-cp filament of parking lamp
	Rear	21-cp filament of tail lamp
	Tail-Tale	2-51
License plate light		2-63
Instrument light		4-55
Ignition lock light		1-51
Map light		N.A.
Dome light		N.A.
Clock light		1-55
Radio dial light		1-44
Glove compartment light		N.A.
Courtesy light		2-82
Trunk compartment light		N.A.
Other Cigarette lighter		1-51
Parking brake		
alarm light		1-82
Tachometer		1-55

ELECTRICAL—FUSE & CIRCUIT BREAKER DATA

Use trade number of fuse, e.g., SFE-10. Indicate circuit breaker by ampere capacity suffixed by letters "C.B.", e.g., 30 C.B. Where fuse or circuit breaker protects multiple circuits indicate first use by a letter and repeat the same letter for all units protected by the same fuse or circuit breaker, e.g., Parking light SFE-10 (a), Direction indicator same as (a).

Headlamp		30 CB (a)
Headlamp beam indicator		Same as (a)
Parking light		Same as (a)
Tail light		Same as (a)
Stop light		Same as (a)
Direction indicator		SFE 11
License plate light		Same as (a)
Instrument light		Same as (a)
Ignition light		Same as (a)
Map light		None
Dome light		None
Clock		Same as (a)
Clock light		Same as (a)
Radio		SFE 11*
Glove compartment light		None
Courtesy light		2-82
Trunk compartment light		None
Other Parking brake		
alarm light		SFE 11
Heater		
(recirculating)		SFE 11*

* - Accessory only

AMA Consolidated Specification Questionnaire

MAKE OF CAR CHEVROLET MODEL YEAR 1953

MODEL CORVETTE

DRIVE UNITS—CLUTCH (PEDAL OPERATED)

Make	None		
Type (dry or wet plate)	--		
In combination with fluid coupling (yes, no)	--		
Semi-centrifugal (yes, no)	--		
Type pressure plate springs	--		
Total plate pressure (lb.)	--		
No. of clutch driven discs	--		
Clutch facing	Material	--	
	Inside diameter	--	
	Outside diameter	--	
	Total eff. area (sq. in.)	--	
	Thickness	--	
	Number required	--	
	Engagement cushioning method	--	
	Release bearing	Type	--
		Method of lubrication	--
	Torsional damping	Method (springs, other)	--
Frict. mat.		--	

DRIVE UNITS—TRANSMISSIONS

Conventional (std. or opt.)	N.A.
Conventional with overdrive (std. or opt.)	N.A.
Automatic (std. or opt.)	Standard

DRIVE UNITS—CONVENTIONAL TRANSMISSION

Number of forward speeds	--	
Transmission ratios	In first	--
	In second	--
	In third	--
	In fourth	--
	In reverse	--
Constant mesh gears in 2nd (yes, no)	--	
Spur gear used in (indicate speeds)	--	
Helical gears used in (indicate speeds)	--	
Synchronous meshing in 2nd and 3rd gears (yes, no)	--	

AMA Consolidated Specification Questionnaire

MAKE OF CAR CHEVROLET MODEL YEAR 1953

MODEL CORVETTE

DRIVE UNITS—CONVENTIONAL TRANSMISSION (cont.)

Lubricant	Capacity (pt.)		--
	Type recommended		--
	SAE viscosity number	Summer	--
		Winter	--
Extreme cold		--	

DRIVE UNITS—CONVENTIONAL TRANSMISSION WITH OVERDRIVE

For transmission data see conventional transmission section			--	
Overdrive	Type (planetary or other)		--	
	If planetary, No. of pinions		--	
	Manual lockout (yes, no)		--	
	Downshift accelerator control (yes, no)		--	
	Minimum cut-in speed		--	
	Gear ratio		--	
	Lubricant	Capacity (O.D. only)		--
		Separate filter (yes, no)		--
		Type recommended		--
		SAE viscosity number	Summer	--
Winter			--	
Ext. cold		--		

DRIVE UNITS—AUTOMATIC TRANSMISSION

Trade name	Powerglide
Type (fluid coupling with gears, torque converter with gears, other)	Torque converter, with gears for automatic shift in Drive range, and Low and Reverse.
Manual selector positions, left to right (show symbols and define, e.g., N- Neutral)	P - Park N - Neutral D - Drive L - Low R - Reverse
List gear ratios in each drive position (range)	3.82:1 to 1:1 - Drive 3.82:1 to 1.82:1 - Low 3.82:1 to 1.82:1 - Reverse
Shifting within drive position range by accelerator control and speed limiting governor (yes, no)	Yes
By governor—forced shift (yes, no)	Yes
Downshift of gears in high range possible up to (mph)	Approximately 48

AMA Consolidated Specification Questionnaire

MAKE OF CAR CHEVROLET MODEL YEAR 1953

MODEL CORVETTE

DRIVE UNITS—AUTOMATIC TRANSMISSION (cont.)

Torque converter	Number of elements		3
	Max. ratio at stall at engine rpm		2.1:1
	Mechanical lockup	Provided (yes, no)	No
		Speed range	--
		Releases at (speed range, mph)	--
	Type of cooling (forced air, oil cooler and type, other)		None
Anti-creep device (yes, no)		No	
Lubricant	Capacity—refill (pt.)		8
	Type recommended		Type A automatic transmission fluid, bearing
	Grade	Summer	AQ-ATF number. Same grade for all temperature
		Winter	ranges.
		Extreme cold	

DRIVE UNITS—PROPELLER SHAFT

Number used		1		
Type (exposed, torque tube)		Exposed Hotchkiss		
Outer diameter x length* x wall thickness	Conventional trans.		--	
	Overdrive trans.		--	
	Automatic trans.		2.50 x .065 (Effective length varies due to U-Joint slip on spline).	
Intermediate bearing	Type (plain, anti-friction)		None	
	Lubri. (fitting, prepack)		None	
Universal joints	Make		Own	
	Number used		2	
	Type (ball and trunnion, cross, other)		Yoke and spider (trunnion)	
	Bearing	Type (plain, anti-friction)		Anti-friction
		Lubric. (fitting, prepack)		2-fittings
Drive taken through (torque tube or arms, spring)		Rear springs		
Torque taken through (torque tube or arms, springs)		Rear springs		

*Centerline to centerline of joints or centerline of rear attachment point.

AMA Consolidated Specification Questionnaire

MAKE OF CAR CHEVROLET MODEL YEAR 1953

MODEL CORVETTE

DRIVE UNITS—REAR AXLE

Type (semi-floating, other)		Semi-floating	
Gear type (hypoid, other)		Hypoid	
Gear ratio and No. of teeth	Conventional trans.	N.A.	
	Overdrive trans.	N.A.	
	Automatic trans.	3.55:1	
Pinion adjustment (shim, other)		Shim	
Pinion bearing adj. (shim, other)		None	
Lubricant	Capacity (pt.)	3-1/2	
	Type recommended	Passenger car Hypoid or Multi-Purpose	
	SAE viscosity number	Summer	SAE 90
		Winter	SAE 90
		Extreme cold	SAE 90

DRIVE UNITS—WHEELS

Type (disc, other)		Short spoke disc
Rim (size and flange type)		15 x 5K
Attachment	Type (bolt or stud)	Bolt
	Circle diameter	4.75
	Number and size	5 x 7/16 x 20

DRIVE UNITS—TIRES

Size and ply rating	Standard	6.70-15-4-White sidewall
	Optional	N.A.
Rev/mile at 30 mph		74.8
Inflation press. (cold)	Front	22# for normal driving - 28# for sustained high speed driving
	Rear	22# for normal driving - 28# for sustained high speed driving

BRAKES—SERVICE

Type		Servo - 4 Wheel Hydraulic	
Booster type		None	
Effective area (sq. in.)		158	
Percent brake effectiveness—rear		17%	
Drum	Diameter	Front	11
		Rear	11
	Type and material		Composite Rim-Cast alloy iron, web-pressed steel

AMA Consolidated Specification Questionnaire

NAME OF CAR CHEVROLET MODEL YEAR 1953

MODEL CORVETTE

BRAKES—SERVICE (cont.)

Brake lining	Bonded or riveted		Bonded		
	Primary	Material		Full-molded, asbestos composition	
		Size (length x width x thickness)	Front wheel	9.3125 x 2.0 x .202-.222	
			Rear wheel	9.3125 x 1.75 x .202-.222	
		Segments per shoe		1	
	Secondary	Material		Full-molded, asbestos composition	
		Size (length x width x thickness)	Front wheel	11.6875 x 2.0 x .202-.222	
			Rear wheel	11.6875 x 1.75 x .202-.222	
		Segments per shoe		1	
	Wheel cylinder bore	Front	1.125		
Rear		1.0			
Master cylinder bore		1.0"			
Available pedal travel		4-1/2"			
Line pressure at 100 lb. pedal load		700 (Approx)			
Shoe clearance adjustment		To light drag and back off 7 notches			

BRAKES—PARKING

Type of control		"T" handle pull rod
Location of control		LH of steering column, below instrument panel
Operates on		Rear service brake shoes
If separate from service brakes	Type (internal or external)	--
	Drum diameter	--
	Lining size (length x width x thickness)	--

FRAME

Type and description	Full length, welded, box-section side and rear cross members. "I" beam type member, bracing from "X" member to frame front side member. Rear shock absorber cross member of "U" type. "I" beam type "X" member.
----------------------	---

FRONT SUSPENSION

Type and description	Unitized, independent, short and long arm
----------------------	---

AMA Consolidated Specification Questionnaire

MAKE OF CAR CHEVROLET MODEL YEAR 1953

MODEL CORVETTE

FRONT SUSPENSION (cont.)

Spring	Type	Coil
	Material	Chrome alloy steel
	Size (length x width x No. leaves or coil I.D.)	13.45 Free length x 4.4460 Max OD x 3.1620 I.D. Total No. of coils 9-3/4
	Spring rate (lb. per in.)	300
	Rate at wheel (lb. per in.)	110
	Normal load (lb. @ rated length)	1145 @ 9.62
Shock absorbers	Manufacturer	Delco
	Type (direct or lever)	Direct, double-acting, hydraulic
	Piston diameter	1
Stabilizer	Type (link, linkless, frameless)	Link
	Material	Heat treated HR carbon steel

STEERING

Type used (Standard or optional)	Mechanical	Standard		
	Power	N.A.		
Wheel diameter		17.25		
Turning diameter	Wall to wall	38.58 Right - 36.99 Left		
	Curb to curb	36.55 Right - 36.93 Left		
Outside wheel angle with inside wheel at 20°		17°		
Mechanical	Gear	Type	Semi-reversible, hour glass worm and ball bearing roller sector	
		Make	Saginaw	
		Ratios	Gear	16.0:1
			Overall	16.0:1
	No. wheel turns (l. to r.) (l. to r.)		3.9	
Power	Type	--		
	Make	--		
	Trade name	--		
	Gear	Type	--	
		Ratios	Gear	--
			Overall	--
	Pump driven by		--	
	Overall torque ratio		--	
	Number wheel turns (l. to r.)		--	
	Linkage	Type	Center Point	
Location (front or rear of wheels)		Rear of wheels		
Drag link (trans. or long)		Longitudinal		
Tie rods (one or two)		2		

AMA Consolidated Specification Questionnaire

MAKE OF CAR CHEVROLET MODEL YEAR 1953

MODEL CORVETTE

STEERING (cont.)

Kingpin	Inclination at camber (deg.)		3-1/2-4-1/2	
	Diameter		.8660-.8665	
	Bearings (type)	Upper		Bushing
		Lower		Bushing
	Thrust		Single Row Ball	
Wheel alignment (range and preferred)	Caster (deg.)		0-1	
	Camber (deg.)		0-1	
	Toe-in (outside tread-inches)		0-1/8"	
Steering knuckle type			Reverse Elliott	
Wheel spindle	Diameter	Inner bearing	1.2810-1.2815	
		Outer bearing	7498 -7503	
	Thread size		3/4-20 AN	
	Bearing type		Ball	

REAR SUSPENSION

Type			Longitudinal Springs		
Drive and torq. taken through (see page 14)			Rear Springs		
Spring	Type		Semi-elliptic		
	Material		Chrome alloy steel		
	Size (length x width x No. leaves or coil I.D.)		51 x 2 x 4		
	Spring rate (lb. per in.)		115		
	Rate at wheel (lb. per in.)		115		
	Normal load (lb. at rated length)		750		
	Mounting insulation type		Rubber bushed		
	If leaf	No. of leaves		4	
		Covers (yes, no)		No	
		Lubricated (yes, no)		No	
		Inserts	Type and size		3 Liners-19.76x1.88x.100-31.76x1.88x.100 - 46.26x1.88x.100
			Material		Wax impregnated fiber board
Shackle (comp. or tens.)			In tension from rear hanger		
Shock absorbers	Manufacturer		Delco		
	Type (direct or lever)		Direct double-acting, hydraulic		
	Piston diameter		1		
Stabilizer	Type (link, linkless, frameless)		None		
	Material		--		
Track bar type			None		

AMA Consolidated Specification Questionnaire

Page 19

MAKE OF CAR CHEVROLET MODEL YEAR 1953

BODY—GENERAL DEFINITIONS

NOTE: Included in the dimension definitions listed on this and the following pages are those which have been proposed for adoption by the SAE. These are indicated by a number following the type of dimension, e.g., L 3. Additional dimensions have been added by the AMA Specifications Body Sub-Committee for inclusion in the Questionnaire. These are shown by an additional letter, e.g., MA. The dimensions are developed from the following basic points:

1. Front and rear seat "A" points are taken 5" forward of vertical tangent to seat back 15" from center of body.
2. Front seat is in the rear position.
3. Loaded position—5 passengers, front 300 lb., rear 450 lb., includes spare wheel, tire and tools, and full complement of gas, oil, water, etc. and tires to recommended pressure, etc.
4. C. L. (centerline).
5. D. L. O. (daylight opening, exposed glass dimension).
6. Ramp breakover angle (page 20)—is the supplement of the included ramp angle over which a car can pass without hanging up.

MODEL CORVETTE

BODY—TRUNK OPENING DIMENSIONS

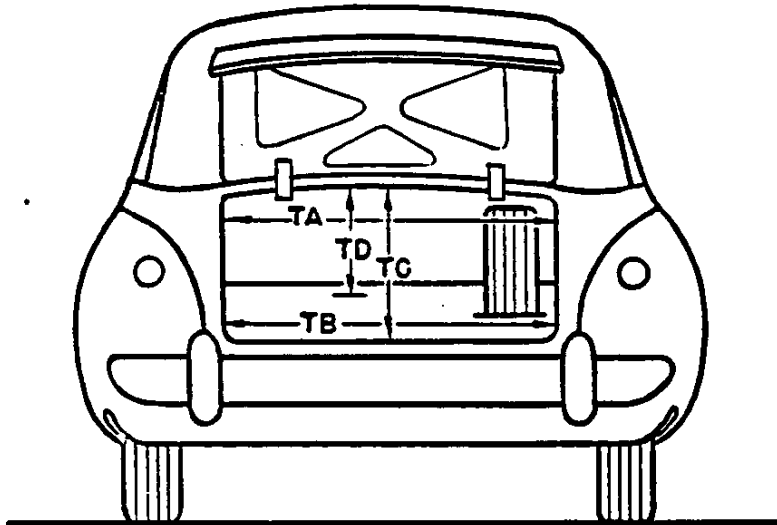

TA—Width across the top	45.96
TB—Width across the bottom	35.00 One inch above floor line
TC—Diagonal dimension at CL from top of opening to bottom	*
TD—Vertical height of opening (floor to top, inside edge of opening)	14.4
Position of spare tire stowage	Horizontal in floor tire well under mat
Method of holding lid open	Counterbalance springs

* - Not a standard dimension.

AMA Consolidated Specification Questionnaire

MAKE OF CAR CHEVROLET MODEL YEAR 1953

MODEL CORVETTE

BODY—HEIGHT DIMENSIONS

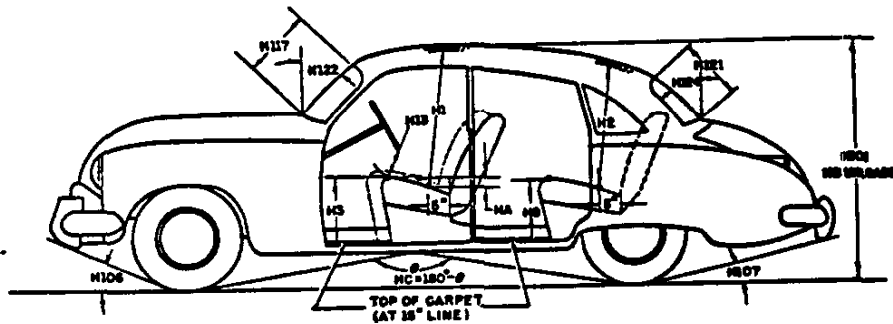

	H1. Front headroom—from "A" pt. to headlining at 8° back of vertical on 15" line. (For "A" pt. see note 1, page 19)	35.40
	H2. Rear headroom—from "A" pt. to headlining at 8° back of vertical on 15" line.	--
Interior	H3. Front seat height to floor carpet on 15" line (front edge of cushion).	8.05-8.27
	H8. Rear seat height to floor carpet on 15" line (front edge of cushion).	--
	H13. Steering wheel clearance to seat cushion taken on arc.	5.30
	H4. Front seat vertical rise at "A" pt. (inches.)	.22
	H101. Overall height. Loaded-Top Up	51.25
	H5. Overall height-unloaded. -Top Up	52.16
	H105. Angle of approach—from the tire rolling radius to lowest point on front bumper or guard.	30°
	H107. Angle of departure—from the tire rolling radius to lowest point on rear bumper or guard.	19° 30'
	H6. Ramp breakover angle.*	165°
Exterior	H117. Windshield DLO-slant height.	16.92
	H121. Backlight DLO*—Max. slant height.	10
	H122. Windshield slope angle to vertical line on car axis.	53°
	H124. Backlight slope angle to vertical line on car axis.	40°
	KD. Min. road clearance (location and dimension).	6 Minimum below door opening
	H7. Min. road clearance at rear axle.	8

*See Notes, page 19.

AMA Consolidated Specification Questionnaire

Page 21

MAKE OF CAR CHEVROLET

MODEL YEAR 1953

MODEL

CORVETTE

BODY—LENGTH DIMENSIONS

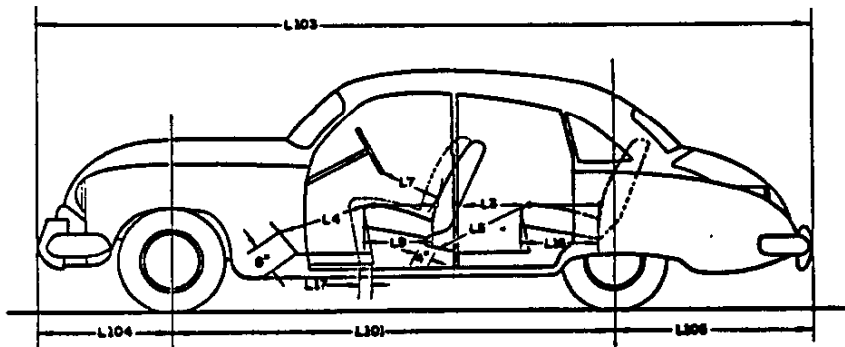

	L3. Rear compartment back of front seat back to rear seat back.	--
	L4. Leg room—front—diagonal—ball of foot to top of seat to front seat back—15° line.	42.00
	L5. Leg room—rear—diagonal—from ball of foot to top of rear seat cushion and to seat back.	--
Interior	L7. Steering wheel clearance to seat back taken on arc.	13.375
	L9. Front seat depth (front edge to vert. tan. to seat back on 15° line).	18.25
	L16. Depth of rear seat (front edge to seat back).	--
	L17. Total adjustment of front seat at floor.	4.4
	L101. Wheel base.	102.00
	L103. Overall length (bumper to bumper inc. guards).	167.00
Exterior	L104. Overhang—front including bumper guards.	26.10
	L105. Overhang—rear including bumper guards.	38.90

AMA Consolidated Specification Questionnaire

MAKE OF CAR CHEVROLET MODEL YEAR 1953

MODEL CORVETTE

BODY—WIDTH DIMENSIONS

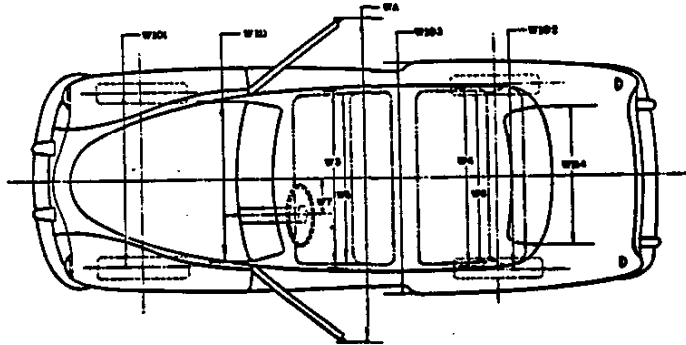

Interior	W3. Front shoulder room, at garnish moulding height or nearest interference 5" forward of seat back.	51.25 -
	W4. Rear shoulder room, at garnish moulding height or nearest interference 5" forward of seat back.	--
	W5. Front hip room, at top of seat 5" forward of vert. tan. to seat back.	57.20
	W6. Rear hip room, at top of seat 5" forward of vert. tan. to seat back.	--
	W7. Steering wheel center to center of body.	14
	W101. Front tread at ground.	57.00
	W102. Rear tread at ground.	59.00
Exterior	W103. Max. overall width of car including bumpers or mouldings.	72.24
	WA. Max. overall width of car with doors open.	10' 5"
	W111. Windshield DLO, max. width.	51.88
	W114. Back window DLO, max. width.	30.88

AMA Consolidated Specification Questionnaire

MAKE OF CAR CHEVROLET MODEL YEAR 1953

MODEL CORVETTE

BODY—TYPES

Body types and number of passengers. (Please use the letter code shown below followed by the number of passengers, e.g. A-6.)

L-Convertible-2 Door - 2 Passenger

Body type code

- | | |
|--|---|
| <ul style="list-style-type: none"> A—Coupe—2 door flatback B—Coupe—2 door notchback C—Sedan—2 door flatback D—Sedan—2 door notchback E—Sedan—4 door flatback (4 windows) F—Sedan—4 door flatback (6 windows) G—Sedan—4 door notchback (4 windows) H—Sedan—4 door notchback (6 windows) J—Hardtop—2 door K—Hardtop—4 door | <ul style="list-style-type: none"> L—Convertible—2 door M—Convertible—4 door N—Station wagon—2 door P—Station wagon—4 door Q—Combined passenger and utility—2 door R—Combined passenger and utility—4 door S—Sedan delivery T—Limousine |
|--|---|

BODY—MISCELLANEOUS INFORMATION

Doors hinged (front, rear)	Front	Rear	Front
			--
Type of finish (lacquer, enamel)	Lacquer		
Hood opening (front, side; semi-full, full, half)	Front - Reverse Alligator		
Hood counterbalanced (yes, no)	No		
Hood release control (internal, external)	Internal		
Windshield (one piece, two piece; curved, flat)	One-piece, curved		
Rear window type (one piece, two piece, three piece; curved, flat)	Plastic one-piece, flat		

AMA Consolidated Specification Questionnaire

Page 24

INDEX

SUBJECT	PAGE	SUBJECT	PAGE
Battery.....	8	Kingpin.....	18
Belts, drive.....	7	Lamp bulbs.....	11
Body		Linings—clutch, brake.....	12, 16
General Body Information.....	19, 23	Lubrication.....	5, 6, 13, 14, 15
Height dimensions.....	20	Muffler.....	6
Length dimensions.....	21	Overdrive.....	13
Overall dimensions.....	1	Piston pins.....	3
Trunk opening dimensions.....	19	Pistons.....	2
Width dimensions.....	22	Propeller shaft.....	14
Types.....	23	Radiator, radiator hoses.....	7
Brakes		Rear axle.....	1, 15
Parking.....	16	Rims.....	15
Service.....	15, 16	Rings.....	3
Camber.....	18	Shock absorbers	
Camshaft.....	4	Front.....	17
Capacities		Rear.....	18
Cooling system.....	7	Spark plugs.....	9
Fuel tank.....	6	Springs	
Lubricants		Front.....	17
Crankcase.....	6	Rear.....	18
Overdrive.....	13	Valve.....	5
Transmissions.....	13, 14	Stabilizer	
Rear axle.....	15	Front.....	17
Carburetor.....	6	Rear.....	18
Caster.....	18	Valve.....	5
Choke, automatic.....	6	Starting motor.....	8
Circuit breakers.....	11	Steering.....	1, 17, 18
Clutch (pedal operated).....	12	Suppression.....	9
Coil, ignition.....	9	Suspension:	
Connecting rods.....	3	Front.....	16, 17
Cooling system.....	7	Rear.....	18
Crankshaft.....	3, 4	Switches.....	10
Cylinders, cylinder head.....	2	Tailpipe.....	6
Distributor.....	9	Timing, engine.....	4, 5, 9
Electrical System.....	8, 9, 10, 11	Tires.....	1, 15
Engine		Toe-in.....	18
Bore and stroke, displacement.....	1, 2	Torque converter.....	14
Compression ratio.....	1, 2	Torque, maximum.....	1, 2
Firing order, cylinder numbering.....	2, 9	Transmission	
General information.....	1, 2	Automatic.....	13, 14
Lubrication.....	5, 6	Conventional.....	12, 13
Type.....	1, 2	Conventional with overdrive.....	13
Exhaust system.....	6	Ratios.....	12
Fan.....	7	Types.....	1, 12, 13
Frame.....	16	Tread.....	1, 22
Fuel.....	6	Turning diameter.....	1, 17
Fuel pump.....	6	Universal joints.....	14
Fuel system.....	6	Valves, intake and exhaust.....	4, 5
Fuses.....	11	Voltage regulator.....	8
Generator.....	8	Water pump.....	7
Horns.....	10	Weight, shipping.....	1
Horsepower.....		Wheel alignment.....	18
Maximum brake.....	1, 2	Wheelbase.....	1, 21
Taxable.....	2	Wheels.....	15
Ignition system.....	9	Wheel spindle.....	18
Instruments.....	10	Windshield wiper.....	10